

**Data Sheet | Item Number: 2061-602/998-404**

SMD PCB terminal block; push-button; 1.5 mm<sup>2</sup>; Pin spacing 6 mm; 2-pole; Push-in  
CAGE CLAMP®; in tape-and-reel packaging; 1,50 mm<sup>2</sup>; white

<https://www.wago.com/2061-602/998-404>



Color: ■ white

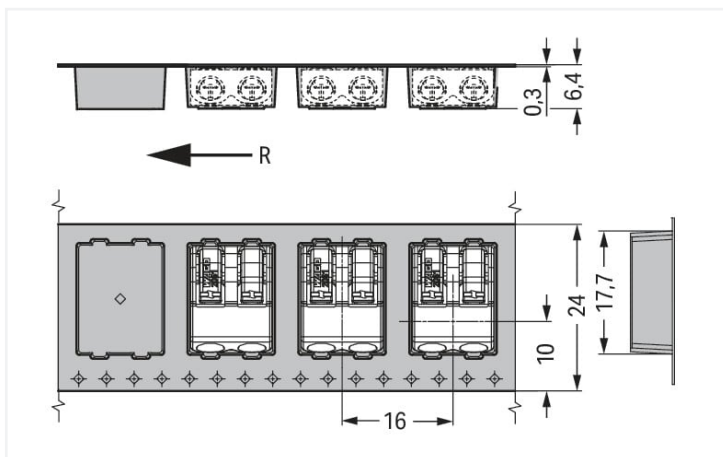

Dimensions in mm  
R = feed direction

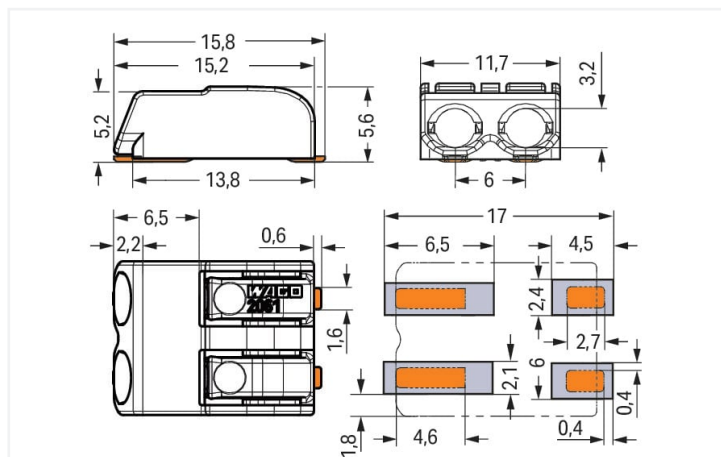

Dimensions in mm

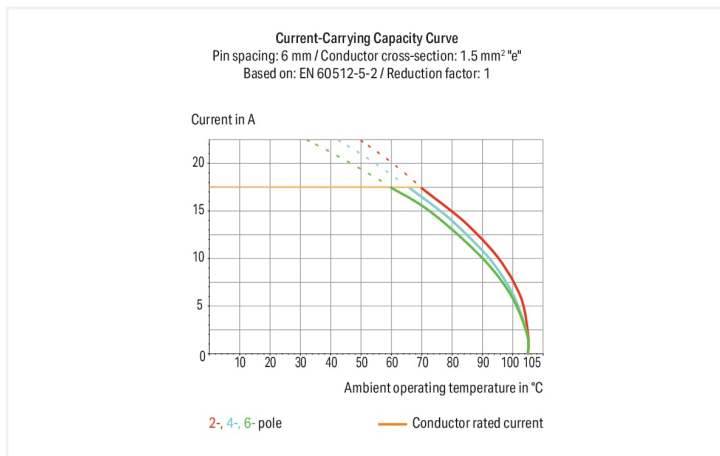

- SMD PCB terminal blocks with Push-in CAGE CLAMP® connection technology and push-buttons
- Just 5.6 mm tall
- Push-in termination of solid and ferruled conductors
- Push-button for easy connection and disconnection of all conductor types
- Available in tape-and-reel packaging for automated assembly

## Notes

### Note

Application notes: Suitable for lead-free, reflow-soldering profiles per DIN EN 61760-1 and IEC 60068-2-58 up to max. 260 °C peak temperature. Due to application-specific variables (component configuration and orientation, type of soldering machine, solder paste), trial runs are recommended to ensure product and process compatibility under actual manufacturing conditions.

Depending on reflow soldering temperatures and times, color deviations may occur. These deviations will have no impact on functionality.

### Recommendation

Recommendation for stencil:  
150 µm material thickness; Pattern layout identical to solder pad layout

## Electrical data

Ratings per	IEC/EN 60664-1			Approvals per	UL 1059		
Overvoltage category	III	III	II	Use group	B	C	D
Pollution degree	3	2	2	Rated voltage	300 V	-	300 V
Nominal voltage	250 V	320 V	630 V	Rated current	10 A	-	10 A
Rated surge voltage	4 kV	4 kV	4 kV				
Rated current	17.5 A	17.5 A	17.5 A				

## Connection data

Clamping units	2	<b>Connection 1</b>	
Total number of potentials	2	Connection technology	Push-in CAGE CLAMP®
Number of connection types	1	Actuation type	Push-button
Number of levels	1	Solid conductor	0.25 ... 1.5 mm <sup>2</sup> / 20 ... 16 AWG
		Fine-stranded conductor	0.5 ... 1.5 mm <sup>2</sup> / 20 ... 16 AWG
		Fine-stranded conductor; with insulated ferrule	0.5 ... 0.75 mm <sup>2</sup>
		Fine-stranded conductor; with uninsulated ferrule	0.5 ... 0.75 mm <sup>2</sup>
		Strip length	7 ... 10 mm / 0.28 ... 0.39 inches
		Conductor connection direction to PCB	0°
		Pole number	2

## Physical data

Pin spacing	6 mm / 0.24 inches
Width	11.7 mm / 0.461 inches
Height	5.6 mm / 0.22 inches
Height from the surface	5.6 mm / 0.22 inches
Depth	15.8 mm / 0.622 inches
Reel diameter of tape-and-reel packaging	330 mm
Tape width	24 mm

## PCB contact

PCB contact	SMD
Solder pin arrangement	over the entire terminal strip (in-line)
Number of solder pins per potential	2

## Material data

Note (material data)	<a href="#">Information on material specifications can be found here</a>
Color	white
Material group	I
Insulation material (main housing)	Polyphthalamide (PPA GF)
Flammability class per UL94	V0
Contact material	Copper alloy
Contact Plating	Tin
Fire load	0 MJ
Weight	1.1 g
MSL per J-STD 020D	1

**Environmental requirements**

Limit temperature range	-60 ... +105 °C
-------------------------	-----------------

**Commercial data**

eCl@ss 10.0	27-14-11-06
eCl@ss 9.0	27-14-11-06
ETIM 9.0	EC001284
ETIM 8.0	EC001284
PU (SPU)	6300 (700) pcs
Packaging type	Box
Country of origin	CN
GTIN	4055143278058
Customs tariff number	85369010000

**Environmental Product Compliance**

RoHS Compliance Status	Compliant, No Exemption
------------------------	-------------------------

**Approvals / Certificates**

**General approvals**



Approval	Standard	Certificate Name
CCA DEKRA Certification B.V.	EN 60947-7-4	NTR NL-7773
CCA DEKRA Certification B.V.	EN 60947-7-4	71-110254
CCA DEKRA Certification B.V.	EN 60838	NTR NL-7721
cURus Underwriters Laboratories Inc.	UL 1059	E45172
KEMA/KEUR DEKRA Certification B.V.	EN 60838	71-106232

**Downloads**

**Environmental Product Compliance**

**Compliance Search**

Environmental Product Compliance 2061-602/998-404	↓
--	---

## Documentation

### Additional Information

Technical Section	03.04.2019	pdf 2027.26 KB	
-------------------	------------	-------------------	--

## CAD/CAE-Data

CAD data	CAE data
2D/3D Models 2061-602/998-404	ZUKEN Portal 2061-602/998-404

## PCB Design

Symbol and Footprint via SamacSys 2061-602/998-404
Symbol and Footprint via Ultra Librarian 2061-602/998-404

## 1 Compatible Products

### 1.1 Optional Accessories

#### 1.1.1 Board-to-board link

##### 1.1.1.1 Board-to-board link



**Item No.: 2061-902**  
Board-to-Board Link; Pin spacing 6 mm;  
2-pole; Length: 30 mm; white

**Item No.: 2061-902/034-000**  
Board-to-Board Link; Pin spacing 6 mm;  
2-pole; Length: 34 mm; white

### 1.1.2 Ferrule

#### 1.1.2.1 Ferrule



**Item No.: 216-241**  
Ferrule; Sleeve for 0.5 mm<sup>2</sup> / 20 AWG; in-  
sulated; electro-tin plated; electrolytic  
copper; gastight crimped; acc. to DIN  
46228, Part 4/09.90; white



**Item No.: 216-201**  
Ferrule; Sleeve for 0.5 mm<sup>2</sup> / 20 AWG; in-  
sulated; electro-tin plated; white



**Item No.: 216-141**  
Ferrule; Sleeve for 0.5 mm<sup>2</sup> / 20 AWG; un-  
insulated; electro-tin plated; electrolytic  
copper; gastight crimped; acc. to DIN  
46228, Part 1/08.92



**Item No.: 216-101**  
Ferrule; Sleeve for 0.5 mm<sup>2</sup> / AWG 22; un-  
insulated; electro-tin plated; silver-colo-  
red



**Item No.: 216-242**  
Ferrule; Sleeve for 0.75 mm<sup>2</sup> / 18 AWG; in-  
sulated; electro-tin plated; electrolytic  
copper; gastight crimped; acc. to DIN  
46228, Part 4/09.90; gray



**Item No.: 216-262**  
Ferrule; Sleeve for 0.75 mm<sup>2</sup> / 18 AWG; in-  
sulated; electro-tin plated; electrolytic  
copper; gastight crimped; acc. to DIN  
46228, Part 4/09.90; gray



**Item No.: 216-202**  
Ferrule; Sleeve for 0.75 mm<sup>2</sup> / 18 AWG; in-  
sulated; electro-tin plated; gray



**Item No.: 216-142**  
Ferrule; Sleeve for 0.75 mm<sup>2</sup> / 18 AWG;  
uninsulated; electro-tin plated; electroly-  
tic copper; gastight crimped; acc. to DIN  
46228, Part 1/08.92



**Item No.: 216-102**  
Ferrule; Sleeve for 0.75 mm<sup>2</sup> / AWG 20; un-  
insulated; electro-tin plated; silver-colored

### 1.1.3 Tool

#### 1.1.3.1 Operating tool



Item No.: [206-866](#)

Operating tool; for 2061 Series

Item No.: [2061-190](#)

Operating tool; made of insulating material

## Installation Notes

### Conductor termination



Inserting solid conductors via push-in termination.

### Conductor termination

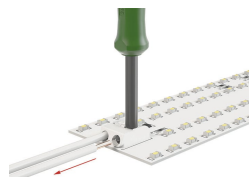

Easy conductor removal, e.g., via operating tool (206-861)