

Key Features

Resistance values from 10mΩ

Low TCR version available for many values

High purity alumina substrate for high power dissipation

RoHS Compliance

MSL Level 1

Applications

Power management applications

Switching power supply

Over current protection in audio applications

Voltage regulation module (VRM)

DC-DC converter, battery pack, charger, adaptor

Disk driver

Type RLC73 Series



TE Connectivity (TE) introduces a new range of current sense resistors to be offered as a low-cost alternative to legacy solutions characterised by noble metal construction (Ag/Pd / RU) and terminations. RLC73 series has the additional benefit of being fully RoHS compliant, and features power ratings up to 2W and TCRs down to 50ppm/°C in the high-power version. Furthermore, these resistors satisfy the demand for low ohmic shunt resistors to act as current sensors towards ICs for battery charge management and low voltage power supplies produced by global semiconductor manufacturers.

Characteristics – Electrical - Standard

Type	Size	Power Rating (W)	Operating Temp. Range	Max Operating Current (A)	Resistance Range (mΩ)			TCR (PPM/C°)
					±1% E24 & E96*	±2% E24	±5% E24	
RLC73	0805	0.125	-55 ~ 155°C	2.5	20 – 50 51 – 100 102 – 196 200 – 1000	20 – 50 51 – 100 110 – 180 200 – 1000	±600 ±400 ±300 ±200	
RLC73	1206	0.25		5.0	10 – 20 22 – 50 51 – 91 100 – 1000	10 – 20 22 – 50 51 – 91 100 – 1000	±600 ±400 ±300 ±200	
RLC73	1210	0.5		7.07	10 – 20 22 – 50 51 – 91 100 – 1000	10 – 20 22 – 50 51 – 91 100 – 1000	±600 ±400 ±300 ±200	
RLC73	2010	0.75		8.66	10 – 20 22 – 50 51 – 91 100 – 1000	10 – 20 22 – 50 51 – 91 100 – 1000	±600 ±400 ±300 ±200	
RLC73	2512	1		10.0	10 – 20 22 – 50 51 – 91 100 – 1000	10 – 20 22 – 50 51 – 91 100 – 1000	±600 ±400 ±300 ±200	

*The nominal resistance value range for less than 100mΩ is in E24 series

Characteristics – Electrical – High Power

Type	Size	Power Rating (W)	Operating Temp. Range	Max Operating Current (A)	Resistance Range (mΩ)			TCR (PPM/C°)
					±1% E24 & E96*	±2% E24	±5% E24	
RLC73P	0805	0.25	-55 ~ 155°C	2.21	20 – 50 51 – 91	20 – 50 51 – 91	±600 ±400	
				1.58	100 – 196 200 – 499 500 – 1000	100 – 180 200 – 470 500 – 1000	±100 ±75 ±50	
RLC73P	1206	0.5		7.07	10 – 20 22 – 50 51 – 68	10 – 20 22 – 50 51 – 68	±600 ±400 ±300	
RLC73P	1206	1		3.65	75 – 100 102 – 147 150 – 1000	75 – 100 110 – 140 150 – 1000	±100 ±75 ±50	
RLC73P	1210	0.75		8.66	10 – 20 22 – 47	10 – 20 22 – 47	±600 ±400	
				3.87	50 – 147 150 – 1000	50 – 140 150 – 1000	±75 ±50	
RL73CP	2010	1		10.0	10 – 20 22 – 47	10 – 20 22 – 47	±600 ±400	
				4.47	50 – 147 150 – 1000	50 – 140 150 – 1000	±75 ±50	
RL73CP	2512	2		14.1	10 – 18	10 – 18	±600	
				10.0	20 – 47	20 – 47	±100	
			6.32	50 – 147 150 – 1000	50 – 140 150 – 1000	±75 ±50		

*The nominal resistance value range for less than 100mΩ is in E24 series

Construction and Dimensions

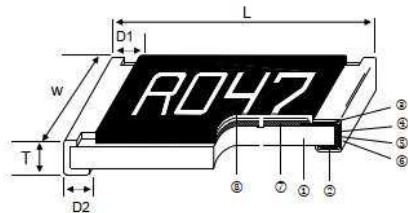

- ① Alumina Substrate
- ② Bottom Electrode
- ③ Top Electrode
- ④ Edge Electrode
- ⑤ Barrier Layer
- ⑥ External Electrode
- ⑦ Resistor Layer
- ⑧ Overcoat

Type	Size	L (mm) ±0.10	W (mm)	T (mm)	D1 (mm)	D2 (mm)	Weight (g) / K pcs
RLC73 / RLC73P	0805	2.00	1.25 ±0.10	0.55 ±0.10	0.30 ±0.20	0.40 ±0.25	4.6
RLC73 / RLC73P	1206	3.10	1.55 ±0.10	0.55 ±0.10	0.50 ±0.30	0.40 ±0.25	8.7
RLC73 / RLC73P	1210	3.10	2.60 ±0.15	0.55 ±0.10	0.50 ±0.30	0.50 ±0.25	16.0
RLC73 / RLC73P	2010	5.00	2.50 ±0.15	0.60 ±0.15	0.60 ±0.30	0.50 ±0.25	23.7
RLC73	2512	6.35	3.10 ±0.15	0.60 ±0.10	0.60 ±0.30	0.55 ±0.25	40.0
RLC73P	2512 10-18mΩ		3.15 ±0.15	0.74 ±0.10		2.10 ±0.10	53.6
	20 – 43mΩ		3.15 ±0.15	0.90 ±0.10		0.60 ±0.30	65.3
	47mΩ		3.10 ±0.15	0.74 ±0.10		210 ±0.10	53.6
	51 – 1000mΩ						

Derating Curve

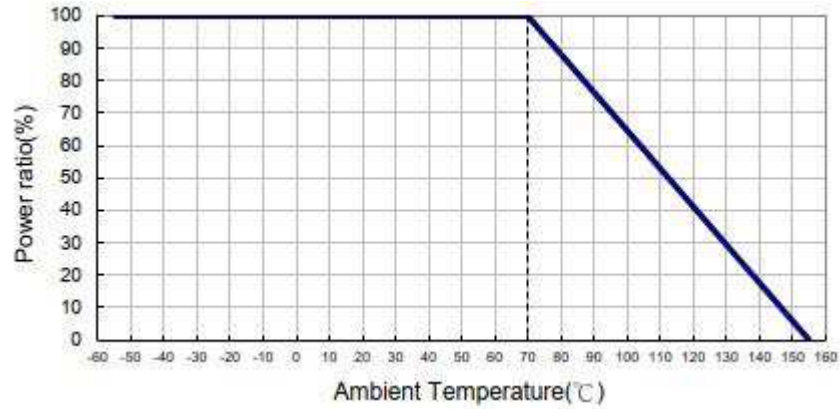

Soldering Profile

■ Soldering Condition (Ref. IPC/JEDEC J-STD-020 & J-STD-002)

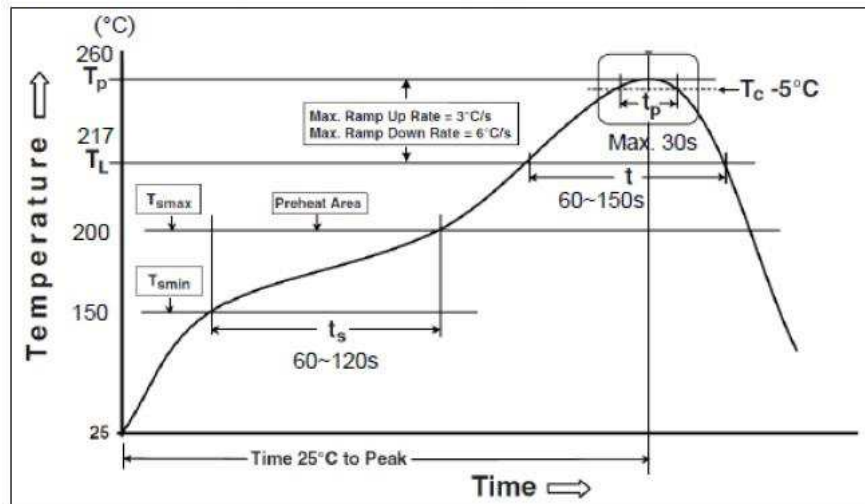

Profile Feature	Pb-Free Assembly
Preheat	
Min. Temperature (T _{smin})	150 °C
Max Temperature (T _{smax})	200 °C
Preheating time (t _s) from (T _{smin} to T _{smax})	60-120 seconds
Ramp-up rate (TL to Tp)	3°C/second max.
Liquidous temperature (TL)	217 °C
Time (t _L) maintained above TL	60-150 seconds
Min. Peak temperature (Tp min)	235°C
Max. Peak temperature (Tp max)	260°C
Time (t _p) within 5 °C of the specified classification temperature (T _c)	30 seconds max.
Ramp-down rate (Tp to TL)	6°C/second max.
Time 25 °C to peak temperature	8 minutes max.

Environmental Characteristics

Item	Requirement	Test Method
Temperature Coefficient of resistance (T.C.R.)	As Spec.	JIS-C-5201-1 4.8 IEC-60115-1 4.8 At 25°C/-55°C and 25°C/+125°C, 25°C is the reference temperature Low TCR: At 25°C/+125°C, 25°C is the reference temperature
Short Time Overload	±(0.5%+0.05Ω)	JIS C 5201-1 4.13 IEC 60115-1 4.13 RCWV*2.5 or Max. Overload Voltage whichever is lower for 5 seconds
	±(1.0%+0.05Ω) For ≤50mR & all High power	
Insulation Resistance	≥10G	JIS-C-5201-1 4.6 IEC-60115-1 4.6 Max. Overload Voltage for 1 minute
Endurance	±(1.0%+0.05Ω)	JIS-C-5201-1 4.25 IEC-60115-1 4.25.1 70±2°C, RCWV for 1000 hrs with 1.5 hrs “ON” and 0.5 hr “OFF”
	±(2.0%+0.05Ω) For ≤50mΩ & all High power	
Damp Heat with Load	±(0.5%+0.05Ω)	JIS-C-5201-1 4.24 IEC-60115-1 4.24 40±2°C, 90~95% R.H., RCWV for 1000 hrs with 1.5 hrs “ON” and 0.5 hr “OFF”
	±(1.0%+0.05Ω) For ≤50mΩ & all High power	
Dry Heat	±(1.0%+0.05Ω)	JIS-C-5201-1 4.23 IEC-60115-1 4.23.2 at +155°C for 1000 hrs
	±(2.0%+0.05Ω) For ≤50mΩ & all High power	
Bending Strength	±(1.0%+0.05Ω)	JIS-C-5201-1 4.33 IEC-60115-1 4.33 Bending once for 60 seconds with 3mm 2010, 2512 sizes: 2mm
Solderability	95% min. coverage	JIS-C-5201-1 4.17 IEC-60115-1 4.17 245±5°C for 3 seconds
Resistance to Soldering Heat	±(0.5%+0.05Ω)	JIS-C-5201-1 4.18 IEC-60115-1 4.18 260±5°C for 10 seconds
Voltage Proof	No breakdown or flashover	JIS-C-5201-1 4.7 IEC-60115-1 4.7 1.42 times Max. Operating Voltage for 1 minute CSN05:300V CSN06/13/10:400V; CSN12:500V
Leaching	Individual leaching area ≤5% Total leaching area ≤10%	JIS-C-5201-1 4.18 IEC-60068-2-58 8.2.1 260±5°C for 30 seconds
Rapid Change of Temperature	±(0.5%+0.05Ω)	JIS-C-5201-1 4.19 IEC-60115-1 4.19 -55°C to +155°C, 5 cycles

RCWV(Rated Continuous Working Voltage)=V(P*R) or Max. Operating Voltage whichever is lower.

Storage Temperature: 15~28°C; Humidity < 80%RH

Shelf Life: 2 years from production date

Packaging

Reel Dimensions (mm)

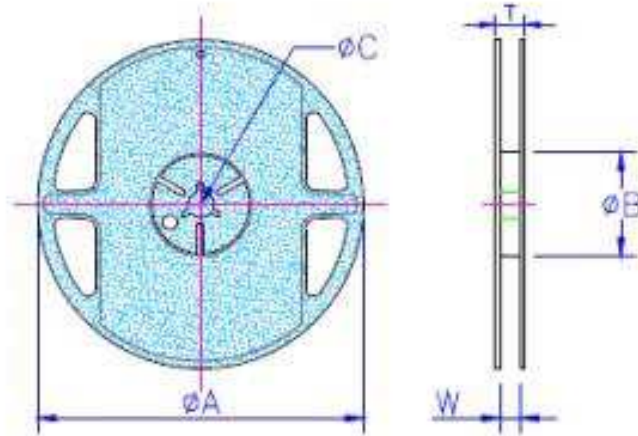

Size	Type	Qty	Tape Width	Reel Diameter	øA (mm)	øB (mm)	øC (mm)	W (mm)	T (mm)
0805 1206 1210	Paper	5K / 1K	8mm	7 inch	178.5 ±1.5	60 +0/-1	13.0 ±0.2	9.0 ±0.5	12.5 ±0.5
2010 2512	Embossed	4K / 1K	12mm	7 inch	178.5 ±1.5	60 +0/-1	13.0 ±0.5	13.0 ±0.5	15.5 ±0.5
2512 2W	Embossed	2K/ 1K	12mm	7 inch	178.5 ±1.5	60 +0/-1	13.0 ±0.5	13.0 ±0.5	15.5 ±0.5

Paper Tape Specifications

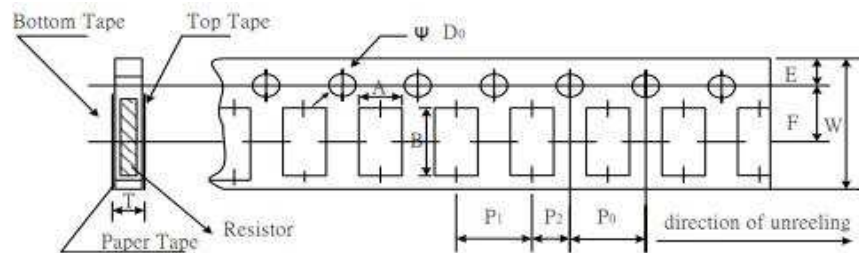

Size	A (mm)	B (mm)	W (mm)	E (mm)	F (mm)	P ₀ (mm)	P ₁ (mm)	P ₂ (mm)	øD ₀ (mm)	T (mm)
	±0.10	±0.20	±0.20	±0.10	±0.05	±0.10	±0.05	±0.05	+0.1 -0	±0.1
0805	1.60	2.40	8.0	1.75	3.50	4.00	4.00	2.00	1.50	0.85
1206	1.90	3.50	8.0	1.75	3.50	4.00	4.00	2.00	1.50	0.85
1210	2.90	3.50	8.0	1.75	3.50	4.00	4.00	2.00	1.50	0.85

Embossed plastic tape specifications

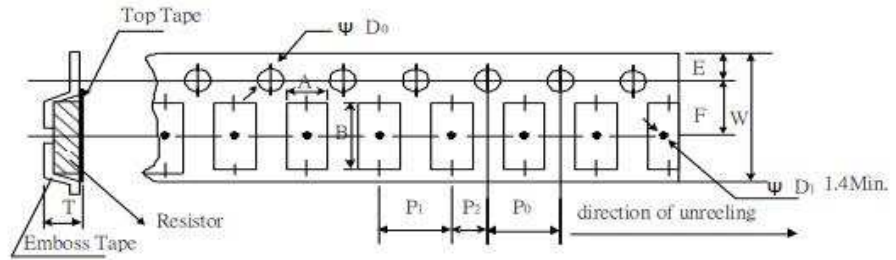

Size	A (mm)	B (mm)	W (mm)	E (mm)	F (mm)	P ₀ (mm)	P ₁ (mm)	P ₂ (mm)	∅D ₀ (mm)	T (mm)
2010	2.80 ±0.10	5.40 ±0.20	12.0 ±0.30	1.75 ±0.10	5.5 ±0.05	4.00 ±0.05	4.00 ±0.10	2.00 ±0.05	1.50 ±0.10	1.00 ±0.20
2512	3.50 ±0.10	6.70 ±0.10	12.0 ±0.30	1.75 ±0.10	5.5 ±0.05	4.00 ±0.05	4.00 ±0.10	2.00 ±0.05	1.50 ±0.10	1.00 ±0.20
2512 2W 20 - 49mΩ	3.50 ±0.10	6.70 ±0.10	12.0 ±0.30	1.75 ±0.10	5.5 ±0.05	4.00 ±0.10	4.00 ±0.10	2.00 ±0.05	1.50 ±0.10	1.45 ±0.20
2512 2W 10 - 18mΩ >49mΩ	3.38 ±0.10	6.68 ±0.10	12.0 ±0.30	1.75 ±0.10	5.5 ±0.10	4.00 ±0.10	4.00 ±0.10	2.00 ±0.05	1.55 ±0.05	1.45 ±0.20

Recommended Land Pattern

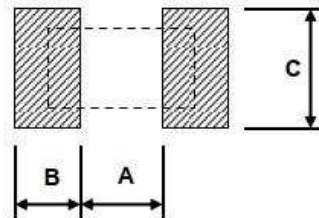

Size	A (mm)	B (mm)	C (mm) ±0.2
0805	1.00	1.00	1.35
1206	2.00	1.15	1.70
1210	2.00	1.15	2.50
2010	3.60	1.40	2.50
2512	4.90	1.60	3.20
2512 2W 20 - 43mΩ	4.90	1.60	3.20
2512 2W 10 - 18mΩ ≥47mΩ	1.00	3.55	3.20

Marking

4 digit marking for all models

Example	Resistance	10mΩ	51mΩ	100mΩ	549mΩ
	Marking	R010	R051	R100	R549

How To Order

RLC73	K	2H	R357	F	TE
Common Part	T.C.R	Size	Resistance Value	Tolerance	Packaging
RLC73 – Standard Power	D - 50ppm W - 75ppm H - 100ppm K - 200ppm	2A - 0805 2B - 1206 2E - 1210 2H - 2010 3A - 2512	R010 – 10mΩ R051 – 51mΩ R100 – 100mΩ	F – 1% G – 2% J – 5%	TDF - 1K RL (all models) TD - 5K RL (0805, 1206, 1210) TE - 4K RL (2010, 2512) TDG - 2K RL (2512 2W)
RLC73P – High Power	N - 300ppm M - 400ppm V - 600ppm				

While TE has made every reasonable effort to ensure the accuracy of the information in this brochure, TE does not guarantee that it is error-free, nor does TE make any other representation, warranty or guarantee that the information is accurate, correct, reliable or current. TE reserves the right to make any adjustments to the information contained herein at any time without notice. TE expressly disclaims all implied warranties regarding the information contained herein, including, but not limited to, any implied warranties of merchantability or fitness for a particular purpose. The dimensions in this data sheet are for reference purposes only and are subject to change without notice. Specifications are subject to change without notice. Consult TE for the latest dimensions and design specifications.