

Miniature Power PCB RYII Hazardous locations & RYII Reflow Solderable Hazardous locations

- 1 pole 8A, 1 form C (CO) or 1 form A (NO) or 1 form B (NC) contact
- Low component height 12.3mm
- 5kV/8mm coil-contact
- Reinforced insulation (protection class II)
- Pinnings: 3.2mm and 5mm
- Reflow-solderable version
- Especially suitable for resistive and inductive loads on form A (NO) and form B (NC) contacts
- Plastic materials according to IEC 60335-1 (domestic appliances)
- Enclosed-break device Group IIA acc. to IEC60079-15:2010 22.4 and Ex dc acc. IEC 60079-1:2014 15.5

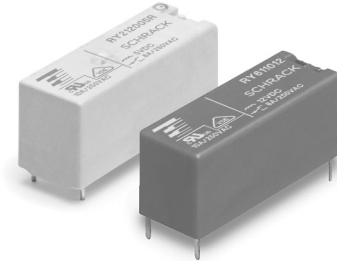

F0142-E

Typical applications
heating control, interface technology, domestic appliances, timers,
temperature control



Approvals

VDE Cert. No. 40009639, UL E214025
Technical data of approved types on request

Contact Data

Contact arrangement	1 form C (CO) or 1 form A (NO) or 1 form B (NC)
Rated voltage	250VAC
Max. switching voltage	400VAC
Rated current	8A
Breaking capacity max.	2000VA
Contact material	AgNi0.15, AgSnO ₂
Frequency of operation, with/without load	6/1200min ⁻¹
Operate/release time max.	9/5ms
Bounce time max., form A/form B	6/10ms

Contact ratings

Type	Contact	Load	Cycles
IEC61810			
RY531	A (NO)	8A, 250VAC, 70°C	100x10 ³
RY211	A (NO)	8A, 250VAC, 75°C	100x10 ³
RY211	A (NO)	8A, 250VAC, 85°C	50x10 ³
RY211	B (NC)	8A, 250VAC, 70°C	50x10 ³
UL61810-1 (UL508)			
RY211	A/B (NO/NC)	10A, 250VAC, general purpose, 70°C	30x10 ³
RY211	A (NO)	1/2hp, 240VAC, 85°C	30x10 ³
RY211	A/B (NO/NC)	B300, 70°C	6x10 ³
RY211	A (NO)	8A, 250VAC, 85°C	100x10 ³
RY211	A (NO)	8A, 24VAC, 85°C	30x10 ³
RY211	A (NO)	B300, 85°C	30x10 ³
RY211	A (NO)	C300, 105°C	30x10 ³
RY211	A (NO)	1/3hp, 250VAC, 85°C	30x10 ³
RY211	A (NO)	1/4hp, 120VAC, 70°C	30x10 ³
EN60730-1			
RY211	A/B (NO/NC)	6(4)A, 250VAC, 85°C	100x10 ³
RY211	A (NO)	8(4)A, 250VAC, 75°C	50x10 ³
RY211	A (NO)	8(4)A, 250VAC, 85°C	30x10 ³
RY211	A (NO)	2(2)A, 250VAC, -40 / +105°C	100x10 ³
RY211	C (CO)	2(2)A, 250VAC, -40 / +105°C	30x10 ³

Mechanical endurance, DC coil	30x10 ⁶ operations
-------------------------------	-------------------------------

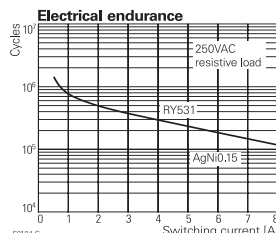
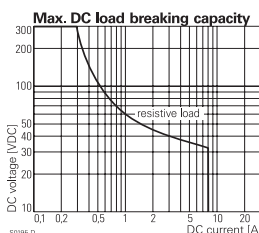

Coil Data

Coil voltage range	5 to 60VDC
Operative range, IEC 61810	2

Coil versions, DC coil

Coil code	Rated voltage VDC	Operate voltage VDC	Release voltage VDC	Coil resistance Ω±10%	Rated coil power mW
005	5	3.5	0.5	112	223
006	6	4.2	0.6	162	222
009	9	6.3	0.9	320	253
012	12	8.4	1.2	627	230
024	24	16.8	2.4	2350	245
048	48	33.6	4.8	9391	245
060	60	42.0	6.0	14000	257

All figures are given for coil without pre-energization, at ambient temperature +23°C
Other coil voltages on request

Coil operating range DC

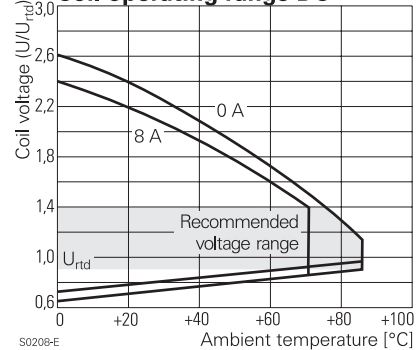

Insulation Data

Initial dielectric strength	
between open contacts	1000V _{rms}
between contact and coil	5000V _{rms}
Clearance/creepage	
between contact and coil	≥8/8mm
Material group of insulation parts	Illa
Tracking index of relay base	PTI250
reflow-solderable version	PTI175

Miniature Power PCB RYII Hazardous locations & RYII Reflow Solderable Hazardous locations (Continued)

Other Data

Material compliance: EU RoHS/ELV, China RoHS, REACH, Halogen content refer to the Product Compliance Support Center at www.te.com/customersupport/rohssupportcenter

Ambient temperature	-40 to +70°C +85°C at 6A
Explosived Atmospheres IEC 60079-15	Enclosed-break device Group IIA ²⁾
Category of environmental protection IEC 61810	RTII - flux proof RTIII - wash tight ¹⁾
Vibration resistance (functional), form A (NO)/form B (NC)	20/5g
Shock resistance (functional) form A (NO)/form B (NC)	20/5g
Shock resistance (destructive)	100g
Terminal type	PCB-THT, PCB-THR
Weight	8g
Resistance to soldering heat THT IEC 60068-2-20	RTII : 270°C/10s RTIII : 260°C/5s
Resistance to soldering heat THR IEC 60068-2-58	250°C, no infrared heating allowed
Packaging/unit standard version	tube/20 pcs., box/500 pcs.
reflow version	reel/280 pcs. box/1120 pcs. (4 reels)

1) not available as reflow-solderable version

2) the enclosures are capable of withstanding normal handling and assembly operations without damage to seals according IEC 60079-15. Only relays without damage an unaffected open louver (e.g. labeling, conformal coating, glue), meet the requirements of IEC 60079-15.

Accessories

For details see datasheet [Accessories Miniature PCB Relay RY](#)

Dimensions

Pinning 3.2mm

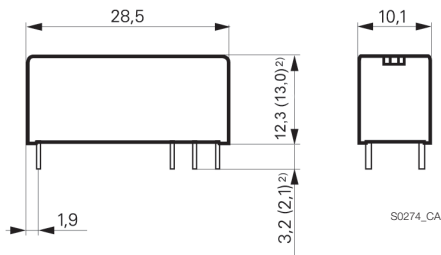

S0274_CA

Pinning 5mm

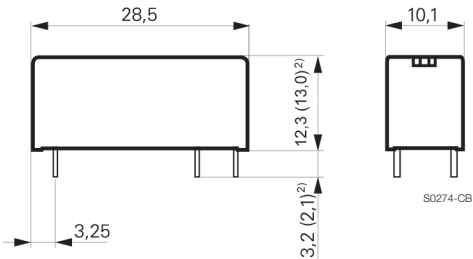

S0274_CB

2) Values in brackets are valid for reflow-solderable version

PCB layout / terminal assignment

Bottom view on solder pins

1 form C (CO) contact, 3.2mm

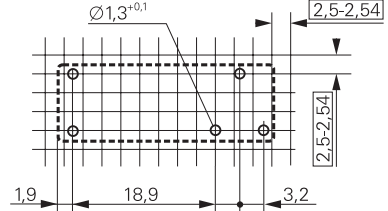

S0254-AA

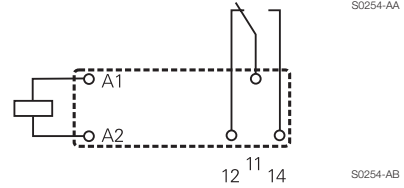

S0254-AB

1 form A (NO), 1 form B (NC) contact 5mm

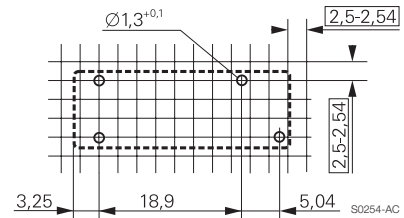

S0254-AC

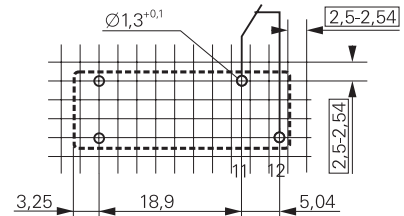

S0254-AE

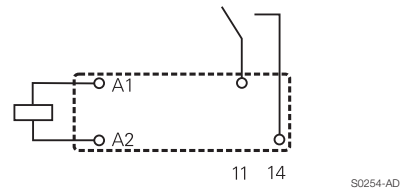

S0254-AD

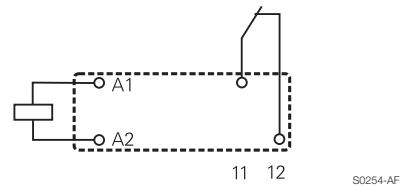

S0254-AF

Miniature Power PCB RYII Hazardous locations & RYII Reflow Solderable Hazardous locations (Continued)

Soldering profile for reflow-solderable version

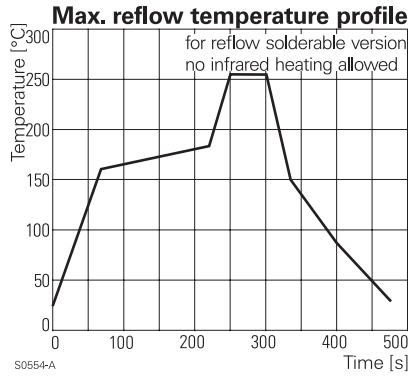

Tape dimensions

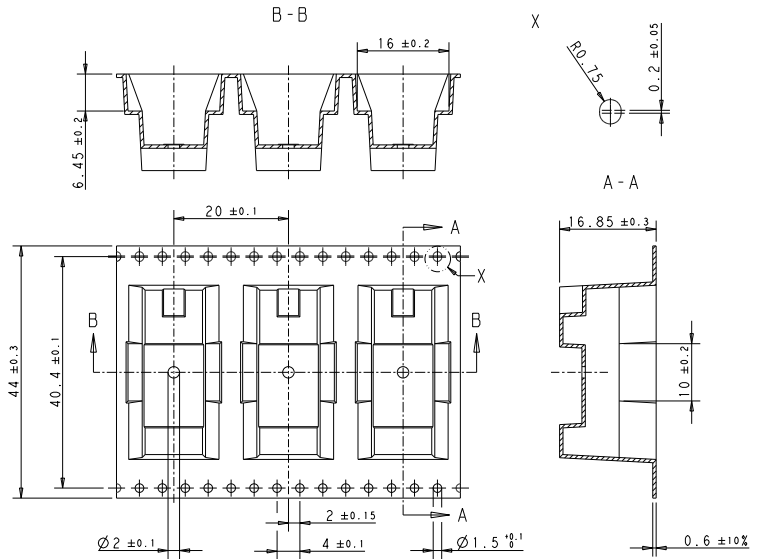

Reel dimensions

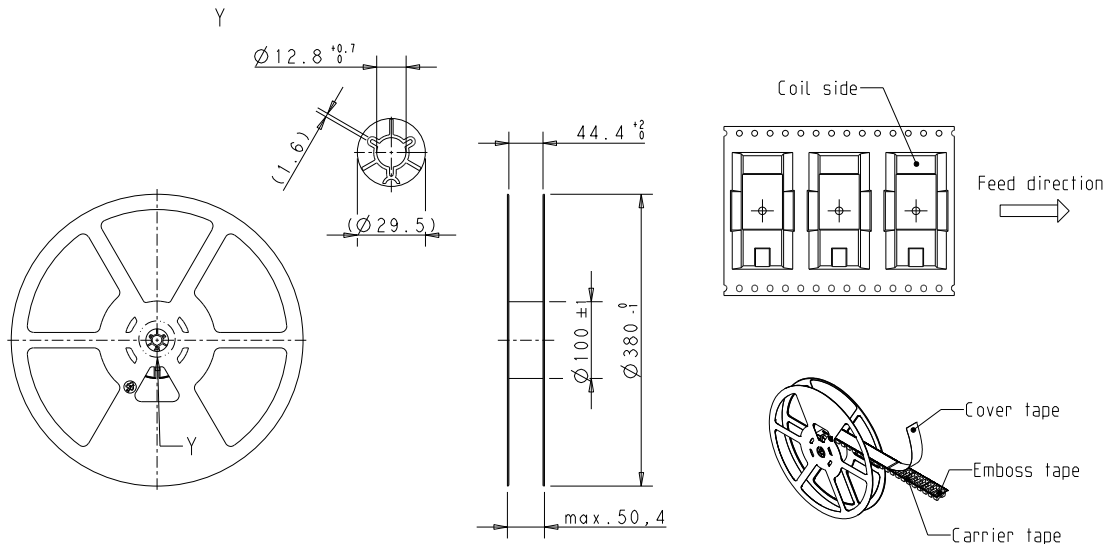

Product code structure

Typical product code **RY 2 1 1 012 EX**

Type	RY Miniature Power PCB RYII & RYII reflow solderable					
Version	2 pinning 3.2mm, flux proof 5 pinning 5mm, flux proof					
Contact arrangement	1 1 form C (1 CO), pinning 3.2mm		3 1 form A (1 NO), pinning 5mm		5 1 form B (1 NC), pinning 5mm	
Contact material	1 AgNi 0.15 3 AgSnO ₂		2 AgNi 0.15 gold plated			
Coil	Coil code: please refer to coil versions table					
Version	EX HazLoc (Enclosed-break device Group IIA) REX reflow-solderable with HazLoc (Enclosed-break device Group IIA)					

Miniature Power PCB RYII Hazardous locations & RYII Reflow Solderable Hazardous locations (Continued)

Product code	Version	Contacts	Contact material	Coil	Part Number
RY211005EX	Pinning 3.2 mm	1 form C,	AgNi 0.15	5VDC	9-1393225-8
RY211009EX	flux proof	1 CO contact		9VDC	9-1393225-9
RY211012EX				12VDC	2-1393226-5
RY211024EX				24VDC	2-1393226-7

Explosive atmospheres

- Equipment protection by type of protection „n“:

Relays are sparking electrical equipment according IEC 60079-15 Explosive atmospheres – Part 15: Equipment protection by type of protection „n“ and can be either approved as enclosed-break devices, or as hermetically sealed devices.

Enclosed-break devices are subjected to a type test filled with and surrounded by an explosive mixture according to the stated group of the equipment, as follows:

- Group IIA: (6.5/0.5) % ethylene/air at atmospheric pressure;
- Group IIB: (27.5/1.5) % hydrogen/air at atmospheric pressure;
- Group IIC: (34.2) % hydrogen, (17.1) % oxygen and the remainder nitrogen at atmospheric pressure or alternatively (27.5/1,5) % hydrogen/air at an overpressure of 500 mbar.

The explosive mixture within the device shall be ignited by the operation of the enclosed contacts, repeated 10 times with a fresh explosive mixture for each test and the explosive mixture surrounding the device shall not be ignited.

Sealed devices are subjected to a type test consisting of (a) voltage test between the terminals and the outer surface of the device and (b) leakage test allowing 3 different methods – see IEC 60079-15.