

# Redundancy unit CP-A RU

## Accessory for CP range power supplies

### Data sheet

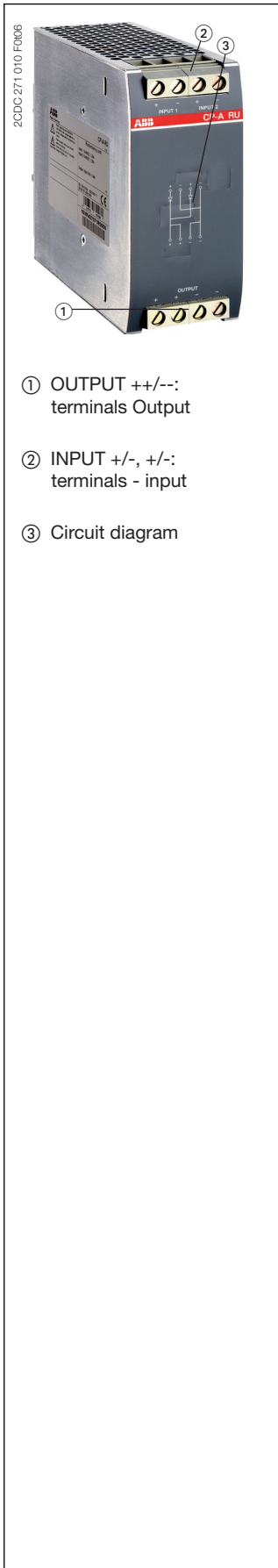

#### Features

- Decoupling of CP power supply units with 2 inputs, each up to 20 A per input / channel
- Output up to 40 A
- True redundancy by 100 % decoupling of two parallel connected power supplies
- 2 integrated diodes for the decoupling of 2 switch mode power supplies up to 20 A
- Control module CP-A CM (accessory) is used to monitor both inputs for undervoltage. One of two relay outputs de-energizes when undervoltage is sensed at an input. The threshold value is adjustable from 14 to 28 V. The CP-A CM plugs onto the front of the CP-A RU unit.

#### Approvals

UL 508, CAN/CSA C22.2 No.14

Approval refers to rated input voltage  $U_{in}$

UL 1604 (Class I, Div 2, hazardous locations),  
CAN/CSA C22.2 No.213

UL 60950, CAN/CSA C22.2 No. 60950

Approval refers to rated input voltage  $U_{in}$

GOST

CB scheme

#### Marks

CE

C-Tick

#### Order data

Type	Description	Order code
CP-A RU	<b>Redundancy unit</b> The CP-A RU provides decoupling of two CP power supply units $\leq 40$ V and $\geq 5$ A.	1SVR 427 071 R0000

#### Order data - Accessories

Type	Description	Order code
CP-A CM	<b>Control module</b> The CP-A CM provides monitoring of the input signals of the redundancy unit CP-A RU.	1SVR 427 075 R0000

#### Application

The redundancy unit CP-A RU provides decoupling of two CP power supply units. It provides automatic redundant power supply operation for critical applications. It has 2 inputs, each up to 20 A, and 1 output up to 40 A.

# Redundancy unit CP-A RU

## Accessory for CP range power supplies

### Data sheet

#### Operating mode

##### Parallel operation, true redundancy with decoupling provided by the CP-A RU

Redundant circuits are used to increase the operational reliability and eliminate power supply outages. Events that can cause a power supply failure include: incorrect wiring, blown fuses, or failure of a single power supply. If a fault event occurs (called initial fault) in the first power supply circuit, power to all loads is then supplied by the second (redundant) power supply. For this reason, both power supplies must be sized to handle the total current requirement of all loads. The primary and the redundant power supplies are decoupled from one another by the CP-A RU unit.

It automatically switches from the primary to the redundant supply after a fault. It decouples the output of the failed power supply from the redundant supply preventing the initial fault from shorting or compromising the redundant supplies' output. In this way, uninterrupted supply of power to all loads is guaranteed.

When available, the two power supplies should be connected to different input voltage phases, to avoid loss of power caused by a blown fuse on the primary side of the power supplies.

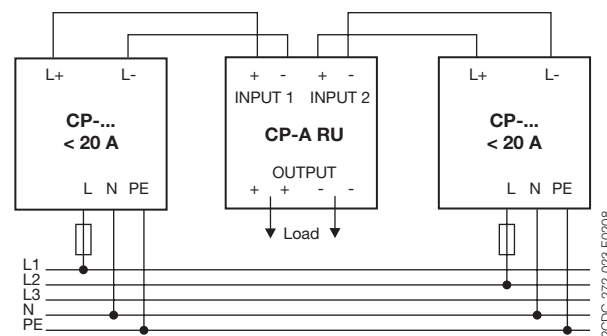

##### Decoupling of power supply units with output currents > 20 A

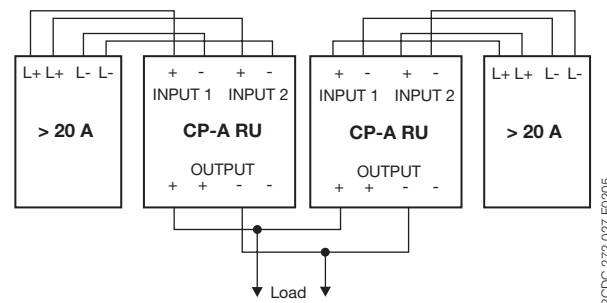

##### Control of input voltages of CP-A RU with CP-A CM

The control module CP-A CM indicates the presence of both input voltages of the CP-A RU via LEDs and energized output relays.

The threshold values for the output relays are adjustable separately per channel from 14 to 28 V. If, by a fault (e.g. failure of a power supply, blown fuse), the voltage in a channel drops below the adjusted threshold value, the corresponding output relay de-energizes. The green LEDs "IN 1", "IN 2" glow, if the corresponding voltage exceeds the adjusted threshold value. The green LED "OUT" glows, if the output voltage is higher than 3 V.

# Redundancy unit CP-A RU

## Accessory for CP range power supplies

### Data sheet

#### Examples of application with accessories

##### CP-A RU with CP-A CM for monitoring of two power supplies -

###### In case of fault: Fault signal

If both relays are de-energized, the voltages of both channels are below the adjusted threshold value (e.g. 20 V). This could mean, that both power supply units failed or are switched off, or that there is an overload on the secondary side. Momentary de-energization of the relays may be caused by inrush current of a connected load, during starting.

If one of the two relays de-energizes, this can indicate that the primary power supply unit failed or is switched off, and the redundant power supply is now supplying power to the load.

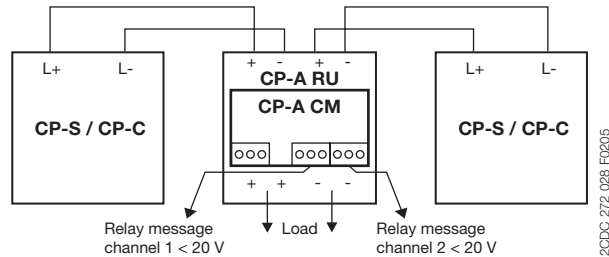

##### CP-A RU with CP-A CM for monitoring of one power supply -

###### In case of fault: Transfer to an alternative power supply

The following example of application shows transferring to an alternative power supply (in this example a battery) after a failure in the primary power supply unit.

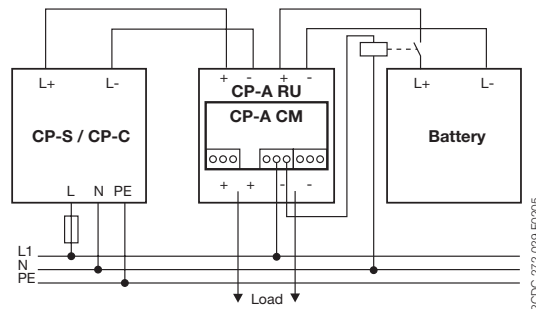

## Installation

### Mounting

The redundancy unit can be snapped on a DIN rail (TH 35-15 or TH 35-7.5 according to IEC/EN 60715) as shown in the accompanying picture. The device is set with its mounting rail slide on the upper edge of the mounting rail and locked by lifting it downwards.

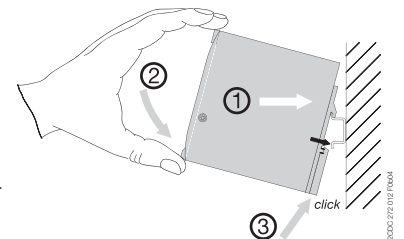

# Redundancy unit CP-A RU

## Accessory for CP range power supplies

### Data sheet

#### Installation

##### Demounting

Remove the redundancy unit as shown in the accompanying picture. The latching lever is pulled downwards by means of the screwdriver. Then the device can be unhinged from the mounting rail edge and removed.

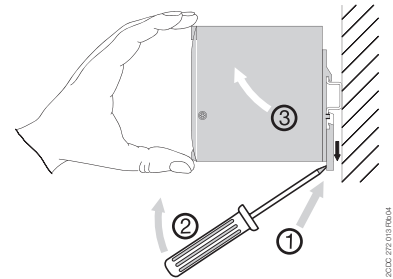

##### Mounting position

The devices have to be mounted horizontally with the input terminals on the top.

In order to ensure a sufficient convection, the minimum distance to other modules must not be less than (A) 10 mm in horizontal direction and (B) 50 mm in vertical direction.

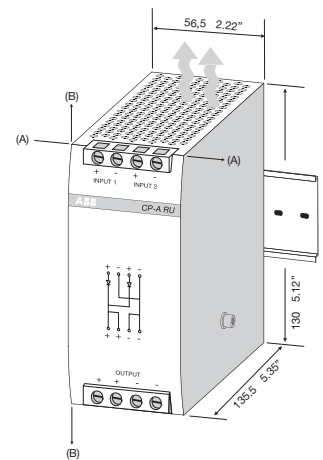

##### Electrical connection - Input side [INPUT 1 + - / INPUT 2 + -]

Connect the input terminals, stripping length of the cable – see technical data. For channel 1 left-hand input terminals + -, for channel 2 right-hand input terminals + -.

##### Electrical connection - Output side [OUTPUT + + --]

Rate the lines for the maximum output current or provide a separate fuse protection. We recommend to choose the cable cross section as large as possible in order to minimize voltage drops. Observe the polarity.

#### Connection diagram

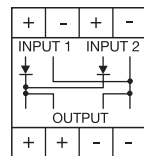

2CDC272 019 F0005

INPUT 1 +, -  
INPUT 2 +, -  
OUTPUT ++, --

Connection of the output of power supply unit 1  
Connection of the output of power supply unit 2  
Output for load

---

# Redundancy unit CP-A RU

## Accessory for CP range power supplies

### Data sheet

---



#### Safety instructions and warnings

The device must be installed by qualified persons only and in accordance with the specific national regulations (e.g., VDE, etc.). These devices are maintenance-free chassis-mounted units.

#### **Disconnect system from supply network!**

Before any installation, maintenance or modification work: Disconnect the system from the supply network and protect against switching on.

#### **Before start of operation:**

Attention! Improper installation/operation may impair safety and cause operational difficulties or destruction of the unit.

#### **Before operation the following must be ensured:**

- Connect to main according to the specific national regulations for class of protection I.
- Power supply cables and unit must be sufficiently fused and rated.
- Rate the output lines sufficiently for the output current and connect them with the correct polarity.
- In order to ensure sufficient air-cooling the distance to other devices has to be considered
- Screws at the enclosure are for internal grounding. Do not remove them! Do not connect cables!

#### **In operation:**

- Do not modify the installation (primary and secondary side)! High current! Risk of electric arcs and electric shock (danger to life)!
- Risk of burns: Depending on the operation conditions the enclosure can become very hot
- If the internal fuse blows, most probably the device is defective. In this case, an examination of the switch mode power supply by the manufacturer is necessary.

#### **Attention! High voltage! Danger to life!**



The power supplies contain components with high stored energy and circuits with high voltage! Do not introduce any objects into the unit, and do not open the unit. With some units of this range the output is capable of providing hazardous energy. Ensure that the service personnel is protected against inadvertent contact with parts carrying energy.

# Redundancy unit CP-A RU

## Accessory for CP range power supplies

### Data sheet

#### Technical data

Data at  $T_a = 25\text{ °C}$ ,  $U_{in} = 230\text{ V AC}$  and rated values, unless otherwise indicated

Type		CP- A RU	CP- A RU in combination with CP-A CM
<b>Input circuit - Supply circuit</b>		(+/-, +/-)	
Rated input voltage $U_{in}$		24 V DC	
Input voltage range per channel		10-28 V DC	13-28 V DC
Rated input current $I_{in}$ per channel		1-20 A	
Maximum input current per channel		30 A for 300 s	
Transient overvoltage protection		yes	
<b>Output circuit</b>		(++/-)	
Rated output voltage $U_{out}$		24 V DC	
Voltage drop		typ. 0.6 V, max. 0.9 V	
Rated output current $I_{out}$		1-40 A	
Output ratings per channel	$T_a = 60\text{ °C}$	10-28 V DC / 40 A	13-28 V DC / 40 A
	$T_a = 70\text{ °C}$	10-28 V DC / 30 A	13-28 V DC / 30 A
Derating	$60\text{ °C} < T_a \leq 70\text{ °C}$	2.5 % per Kelvin temperature increase	
Peak output current		60 A for 300 s	
Resistance to reverse feed		< 40 V	
<b>General data</b>			
Dimensions (W x H x D)		56.5 (60 <sup>1)</sup> ) x 130 x 137 mm (2.22 (2.36 <sup>1)</sup> ) x 5.12 x 5.39 in)	
Weight		0.89 kg (1.96 lb)	
Minimum distance to other units	horizontal / vertical	10 mm / 50 mm (0.39 in / 1.97 in)	
Degree of protection	enclosure / terminals	IP20 / IP20	
Material of enclosure	enclosure shell / cover	aluminium / zinc-coated sheet steel	
Protection class		III <sup>2)</sup>	
Mounting		DIN rail (IEC/EN 60715)	
Mounting position		horizontal	
<b>Electrical connection - Input circuit / Output circuit</b>			
Wire size	fine-strand with wire end ferrule	2.5-10 mm <sup>2</sup> (14-8 AWG)	
	fine-strand without wire end ferrule	0.5-10 mm <sup>2</sup> (20-8 AWG)	
	rigid	0.5-16 mm <sup>2</sup> (20-6 AWG)	
Stripping length		12 mm (0.47 in)	
Tightening torque		1.2-1.5 Nm	
<b>Environmental data</b>			
Ambient temperature range	operation	-25...+70 °C	
	rated load	-25...+60 °C (without derating)	
	storage	-40...+85 °C	
Damp heat (IEC/EN 60068-2-3)		93 % at 40 °C, no condensation	
Climatic category (IEC/EN 60721)		3K3	
Vibration (IEC/EN 60068-2-6)			
Shock (IEC/EN 60068-2-27)			
<b>Isolation data</b>			
Insulation voltage	between input / output / enclosure	500 V AC (routine test)	
Pollution degree (EN 50178)		2	
<b>Standards</b>			
Product standard		IEC/EN 61204	
Low Voltage Directive		2006/95/EG	
EMC Directive		2004/108/EG	

# Redundancy unit CP-A RU

## Accessory for CP range power supplies

### Data sheet

Type	CP- A RU	CP- A RU in combination with CP-A CM
RoHS Directive	2002/95/EC	
Electrical safety	EN 50178, EN 60950, UL 60950, UL 508	
<b>Electromagnetic compatibility</b>		
Interference immunity to	IEC/EN 61000-6-2	
electrostatic discharge	IEC/EN 61000-4-2	Level 3 (air discharge $\pm 8$ kV, contact discharge $\pm 6$ kV)
radiated, radio-frequency, electromagnetic field	IEC/EN 61000-4-3	Level 3 (10 V/m)
electrical fast transient / burst	IEC/EN 61000-4-4	Level 3 ( $\pm 2$ kV)
surge	IEC/EN 61000-4-5	Level 1 ( $\pm 0.5$ kV)
conducted disturbances, induced by radio-frequency fields	IEC/EN 61000-4-6	Level 3 (10 V)
Interference emission	IEC/EN 61000-6-3	
high-frequency radiated	IEC/CISPR 22 / EN 55022	Class B
high-frequency conducted	IEC/CISPR 22 / EN 55022	Class B

<sup>1)</sup> incl. lateral screw

<sup>2)</sup> This device is designed for connection to a safety extra-low voltage source. If no safety extra-low voltage is used at the input side, the lateral screw can be used for grounding of the enclosure (protection class I).

### Dimensions

in mm

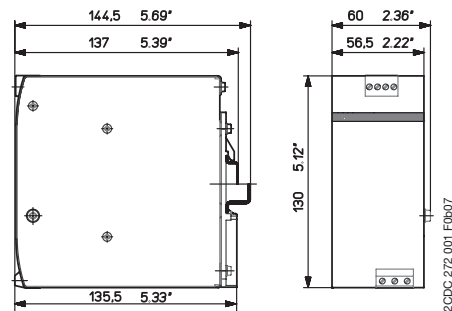

CP-A RU

### Dimensions accessories

in mm

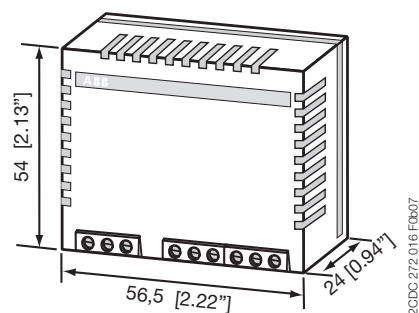

CP-A CM

---

# Redundancy unit CP-A RU

## Accessory for CP range power supplies

### Data sheet

---

#### Further Documentation

Document title	Document type	Document number
Electronic Products and Relays	Technical catalogue	2CDC 110 004 C020x
Power Supply Units	Application manual	2CDC 114 048 M0201
Control module CP-A CM	Data sheet	2CDC 114 037 D0202
CP-E 12/10.0	Data sheet	2CDC 114 059 D0201
CP-E 24/5.0	Data sheet	2CDC 114 060 D0201
CP-E 24/10.0	Data sheet	2CDC 114 061 D0201
CP-E 24/20.0	Data sheet	2CDC 114 062 D0201
CP-S 24/5.0	Data sheet	2CDC 114 008 D0203
CP-S 24/10.0	Data sheet	2CDC 114 009 D0203
CP-S 24/20.0	Data sheet	2CDC 114 010 D0203
CP-C 24/5.0	Data sheet	2CDC 114 011 D0203
CP-C 24/10.0	Data sheet	2CDC 114 012 D0203
CP-C 24/20.0	Data sheet	2CDC 114 013 D0203

You can find the documentation in the internet under [www.abb.com/lowvoltage](http://www.abb.com/lowvoltage) → Control Products → Power Supplies

# Contact us

## **ABB STOTZ-KONTAKT GmbH**

P. O. Box 10 16 80  
69006 Heidelberg, Germany  
Phone: +49 (0) 6221 7 01-0  
Fax: +49 (0) 6221 7 01-13 25  
E-mail: [info.desto@de.abb.com](mailto:info.desto@de.abb.com)

You can find the address of your  
local sales organisation on the  
ABB home page  
<http://www.abb.com/contacts>  
-> Low Voltage Products and Systems

### **Note:**

We reserve the right to make technical changes or modify the contents of this document without prior notice. With regard to purchase orders, the agreed particulars shall prevail. ABB AG does not accept any responsibility whatsoever for potential errors or possible lack of information in this document.

We reserve all rights in this document and in the subject matter and illustrations contained therein. Any reproduction, disclosure to third parties or utilization of its contents – in whole or in parts – is forbidden without prior written consent of ABB AG.

Copyright© 2010 ABB  
All rights reserved