

# PCB terminal block - FFKDSA1/V2-5,08- 2



1986592

<https://www.phoenixcontact.com/pc/products/1986592>

Please be informed that the data shown in this PDF document is generated from our Online Catalog. Please find the complete data in the user documentation. Our General Terms of Use for Downloads are valid.

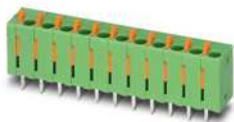

PCB terminal block, nominal current: 15 A, rated voltage (III/2): 400 V, nominal cross section: 1.5 mm<sup>2</sup>, number of potentials: 2, number of rows: 1, number of positions per row: 2, product range: FFKDS(A)/V2, pitch: 5.08 mm, connection method: Push-in spring connection, mounting: Wave soldering, conductor/PCB connection direction: 90 °, color: green, Pin layout: Linear pinning, Solder pin [P]: 3.4 mm, number of solder pins per potential: 2, type of packaging: packed in cardboard

## Your advantages

- Time saving push-in connection, tools not required
- Defined contact force ensures that contact remains stable over the long term
- Intuitive use through colour coded actuation lever
- Operation and conductor connection from one direction enable integration into front of device
- Two solder pins reduce the mechanical strain on the soldering spots
- The latching on the side enables various numbers of positions to be combined
- Vertical connection enables multi-row arrangement on the PCB

## Commercial Data

Item number	1986592
Packing unit	50 pc
Minimum order quantity	1 pc
Product Key	AALBAN
GTIN	4017918921538
Weight per Piece (including packing)	2.469 g
Weight per Piece (excluding packing)	2.069 g
Customs tariff number	85369010
Country of origin	DE

1986592

<https://www.phoenixcontact.com/pc/products/1986592>

## Technical Data

### Product properties

Type	PC terminal block can be aligned
Product line	COMBICON Terminals S
Product type	Printed circuit board terminal
Number of positions	2
Pitch	5.08 mm
Number of connections	2
Number of rows	1
Number of potentials	2
Pin layout	Linear pinning
Solder pins per potential	2

### Electrical properties

Nominal current $I_N$	15 A
Nominal voltage $U_N$	400 V
Degree of pollution	3
Rated voltage (III/3)	250 V
Rated surge voltage (III/3)	4 kV
Rated voltage (III/2)	400 V
Rated surge voltage (III/2)	4 kV

### Connection data

#### Connection technology

Type	PC terminal block can be aligned
Nominal cross section	1.5 mm <sup>2</sup>

#### Conductor connection

Connection method	Push-in spring connection
Conductor cross section solid	0.2 mm <sup>2</sup> ... 1.5 mm <sup>2</sup>
Conductor cross section flexible	0.2 mm <sup>2</sup> ... 1.5 mm <sup>2</sup>
Conductor cross section AWG	24 ... 16
Conductor cross section flexible, with ferrule without plastic sleeve	0.25 mm <sup>2</sup> ... 0.75 mm <sup>2</sup>
Conductor cross section, flexible, with ferrule, with plastic sleeve	0.25 mm <sup>2</sup> ... 0.75 mm <sup>2</sup>
Stripping length	10 mm

### Mounting

Mounting type	Wave soldering
Pin layout	Linear pinning

### Material specifications

# PCB terminal block - FFKDSA1/V2-5,08- 2

1986592

<https://www.phoenixcontact.com/pc/products/1986592>

## Material data - contact

Note	WEEE/RoHS-compliant, free of whiskers according to IEC 60068-2-82/JEDEC JESD 201
Contact material	Cu alloy
Surface characteristics	Tin-plated
Metal surface terminal point (top layer)	Tin (5 - 7 µm Sn)
Metal surface terminal point (middle layer)	Nickel (2 - 3 µm Ni)
Metal surface soldering area (top layer)	Tin (5 - 7 µm Sn)
Metal surface soldering area (middle layer)	Nickel (2 - 3 µm Ni)

## Material data - housing

Color (Housing)	green (6021)
Insulating material	PA
Insulating material group	I
CTI according to IEC 60112	600
Flammability rating according to UL 94	V0
Glow wire flammability index GWFI according to EN 60695-2-12	850
Glow wire ignition temperature GWIT according to EN 60695-2-13	775
Temperature for the ball pressure test according to EN 60695-10-2	125 °C

## Material data – actuating element

Color ()	()
Insulating material	PA
Insulating material group	I
CTI according to IEC 60112	600
Flammability rating according to UL 94	V0
Glow wire flammability index GWFI according to EN 60695-2-12	850
Glow wire ignition temperature GWIT according to EN 60695-2-13	775
Temperature for the ball pressure test according to EN 60695-10-2	125 °C

## Dimensions

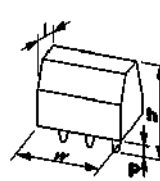
Dimensional drawing	
Pitch	5.08 mm
Width [w]	12.7 mm
Height [h]	19.2 mm
Length [l]	10 mm
Installed height	15.8 mm

# PCB terminal block - FFKDSA1/V2-5,08- 2



1986592

<https://www.phoenixcontact.com/pc/products/1986592>

Solder pin length [P]	3.4 mm
PCB design	
Pin spacing	7.62 mm

## Electrical tests

### Air clearances and creepage distances |

Specification	IEC 60947-1:2007-06 + A1:2010-12 + A2:2014-09
Insulating material group	I
Comparative tracking index (IEC 60112)	CTI 600
Rated insulation voltage (III/3)	250 V
Rated surge voltage (III/3)	4 kV
minimum clearance value - non-homogenous field (III/3)	3 mm
minimum creepage distance (III/3)	3.2 mm
Rated insulation voltage (III/2)	400 V
Rated surge voltage (III/2)	4 kV
minimum clearance value - non-homogenous field (III/2)	3 mm
minimum creepage distance (III/2)	3 mm
Rated insulation voltage (II/2)	630 V
Rated surge voltage (II/2)	4 kV
minimum clearance value - non-homogenous field (II/2)	3 mm
minimum creepage distance (II/2)	3.2 mm

## Environmental and real-life conditions

### Ambient conditions

Ambient temperature (operation)	-40 °C ... 100 °C (Depending on the current carrying capacity/derating curve)
Ambient temperature (storage/transport)	-40 °C ... 70 °C
Relative humidity (storage/transport)	30 % ... 70 %
Ambient temperature (assembly)	-5 °C ... 100 °C

## Packaging specifications

Type of packaging	packed in cardboard
-------------------	---------------------

# PCB terminal block - FFKDSA1/V2-5,08- 2



1986592

<https://www.phoenixcontact.com/pc/products/1986592>

## Approvals



**EAC**

Approval ID: B.01687



**cULus Recognized**

Approval ID: E60425-19870330

	Nominal Voltage $U_N$	Nominal Current $I_N$	Cross Section AWG	Cross Section $\text{mm}^2$
Use group B	300 V	10 A	24 - 16	-
Use group D	300 V	10 A	24 - 16	-

# PCB terminal block - FFKDSA1/V2-5,08- 2



1986592

<https://www.phoenixcontact.com/pc/products/1986592>

## Classifications

### ECLASS

ECLASS-9.0	27440401
ECLASS-10.0.1	27440401
ECLASS-11.0	27460101

### ETIM

ETIM 8.0	EC002643
----------	----------

### UNSPSC

UNSPSC 21.0	39121400
-------------	----------

# PCB terminal block - FFKDSA1/V2-5,08- 2



1986592

<https://www.phoenixcontact.com/pc/products/1986592>

## Environmental Product Compliance

China RoHS	Environmentally friendly use period: unlimited = EFUP-e No hazardous substances above threshold values
------------	---

Phoenix Contact 2023 © - all rights reserved  
<https://www.phoenixcontact.com>

PHOENIX CONTACT GmbH & Co. KG  
Flachmarktstraße 8  
D-32825 Blomberg  
+49 (0) 5235-3 00  
[info@phoenixcontact.com](mailto:info@phoenixcontact.com)