

Multi-Mount Monitor Installation, Operation and Maintenance



Made in the
United States of America



Figure 1. Desco Multi-Mount Monitor

Description

The Desco Multi-Mount Monitor is a single workstation continuous monitor. It continuously monitors the path-to-ground integrity of one operator and one ESD worksurface. Mounting tabs make it suitable to install in workbench or equipment settings. Connect the [19653](#) Remote Alarm accessory to the Multi-Mount Monitor, and place it in the operator's field of view for increased alarm visibility.

The Multi-Mount Monitor is designed with Wave Distortion Technology which provides stable continuous monitoring of the path-to-ground and presence of 1 megohm resistance of an operator's wrist strap. Audio and visual alarms activate (in less than 50 milliseconds) when the operator unintentionally disconnects from the monitor or the wrist strap connection points are intermittent. The Multi-Mount Monitor also monitors for a worksurface path-to-ground of less than 10 megohms. All Multi-Mount Monitors are calibrated to NIST standards and include a certificate.

WAVE DISTORTION

Wave Distortion Technology is the Most Reliable Technology for the Continuous Monitoring of Single-Wire (Conductor) Wrist Straps

"Wave Distortion" or vector impedance works by applying a continuous test voltage of 1.2 volts peak-to-peak at 1 to 2 microamperes (0.000002 amperes) to the wrist strap that is connected to the continuous or constant monitor. The test voltage creates a square wave that the monitor circuit compares to established patterns. By monitoring the "distortions", or shape of the square wave, Wave Distortion Technology determines if the monitored circuit is complete - the operator is in the circuit and the total equivalent DC resistance is within specifications. Wave Distortion Technology produces a very fast alarm time (<50 milliseconds) and minimal false alarms.

ANSI/ESD S20.20 section 7.3 states "Compliance verification records shall be established and maintained to provide evidence of conformity to the technical requirements." Per ANSI/ESD S1.1 Annex A.3 Daily (wrist strap system) testing may be omitted if constant monitoring used." Per ESD Handbook ESD TR 20.20 section 5.3.2.4.4 "Typical Test programs recommend that wrist straps that are used daily should be tested daily. However, if the products that are being produced are of such value that knowledge of a continuous, reliable ground is needed, and then continuous monitoring should be considered or even required."

The Multi-Mount Monitor and its accessories are available as the following item numbers:

| Item | Description |
|-----------------------|---|
| 19651 | Multi-Mount Monitor, North American Power Adapter |
| 19652 | Multi-Mount Monitor, Universal Power Adapter |
| 19653 | Remote Alarm |
| 19258 | Power Adapter, 100-240VAC Input, 24VDC 150mA Output, IEC Inlet |
| 19260 | Power Adapter, 100-240VAC Input, 24VDC 150mA Output, North America Plug |
| 98221 | Wave Distortion Monitor Verification Tester |

Packaging

19651 Multi-Mount Monitor, North America

- 1 Multi-Mount Monitor
- 1 Mat Monitor Cord (White)
- 1 Countersunk Washer
- 1 Flat Head Screw, 6-32 x 1/4"
- 2 Pan-Head Screws, #6 x 3/8"
- 1 Dual Lock Fastener Set, 2" Length
- 1 Power Adapter, 24VDC, North America Plug
- 1 Certificate of Calibration



Figure 2. North American power adapter included with the 19651 Multi-Mount Monitor

19652 Multi-Mount Monitor, Universal Power Adapter

- 1 Multi-Mount Monitor
- 1 Mat Monitor Cord (White)
- 1 Countersunk Washer
- 1 Flat Head Screw, 6-32 x 1/4"
- 2 Pan-Head Screws, #6 x 3/8"
- 1 Dual Lock Fastener Set, 2" Length
- 1 10mm Interchangeable Park Snap
- 1 10mm Operator Jack Adapter
- 1 Power Adapter, 24VDC, IEC Inlet
- 1 Certificate of Calibration



Figure 3. Universal power adapter included with the 19652 Multi-Mount Monitor

NOTE: The power cord must be purchased separately if ordering the 19652 Multi-Mount Monitor. The power cords are available as the following item numbers:

| Item | Plug Type |
|-----------------------|----------------|
| 50545 | Europe |
| 50546 | United Kingdom |

19653 Remote Alarm

- 1 Remote Alarm
- 1 Remote Cable, 7' Length
- 2 Pan-Head Screws, #6 x 3/8"
- 1 Dual Lock Fastener Set, 1" Length



Figure 4. Desco 19653 Remote Alarm

Features and Components

Multi-Mount Monitor



Figure 5. Multi-Mount Monitor features and components

A. Mat Monitor Switch: Use a probe to access the mini slide switch. Slide the switch to the right to enable the mat monitor circuit. Slide the switch to the left to disable the mat monitor circuit. This switch is enabled as default.

B. Buzzer Volume Adjustment: Turn the trimpot clockwise to increase the buzzer volume. Turn the trimpot counter-clockwise to decrease the buzzer volume.

C. Monitored Operator Jack: Insert the single-wire wrist cord here to monitor the operator's connection to ground.

D. Operator LEDs: Illuminates green when the operator is properly grounded. Illuminates solid red and audible alarm sounds when the operator is not properly grounded.

E. Mat LEDs: Illuminates green when the worksurface is properly grounded. Illuminates red and audible alarm sounds when the worksurface is not properly grounded.

F. Park Snap: Allows the operator to disconnect (and park) a wrist strap when leaving the workstation, without creating a false alarm. Touch the park snap and the monitor's audible alarm will disable for approximately 10 seconds. Use this time to disconnect the wrist cord from the wristband, and attach it to the park snap or remove the banana plug from the jack. Upon returning to the workstation and disconnecting the wrist cord from the park snap, the operator has approximately 10 seconds to reconnect the wrist cord to a worn wristband before activating the alarm.

G. Mat Monitor Screw Terminal: Verifies that the worksurface's path-to-ground is <10 megohms. Connect the white mat monitor cord here.

H. Power Jack: Connect the included 24VDC power adapter here.

I. Remote Alarm Jack: Connects to the [19653](#) Remote Alarm accessory.

Remote Alarm

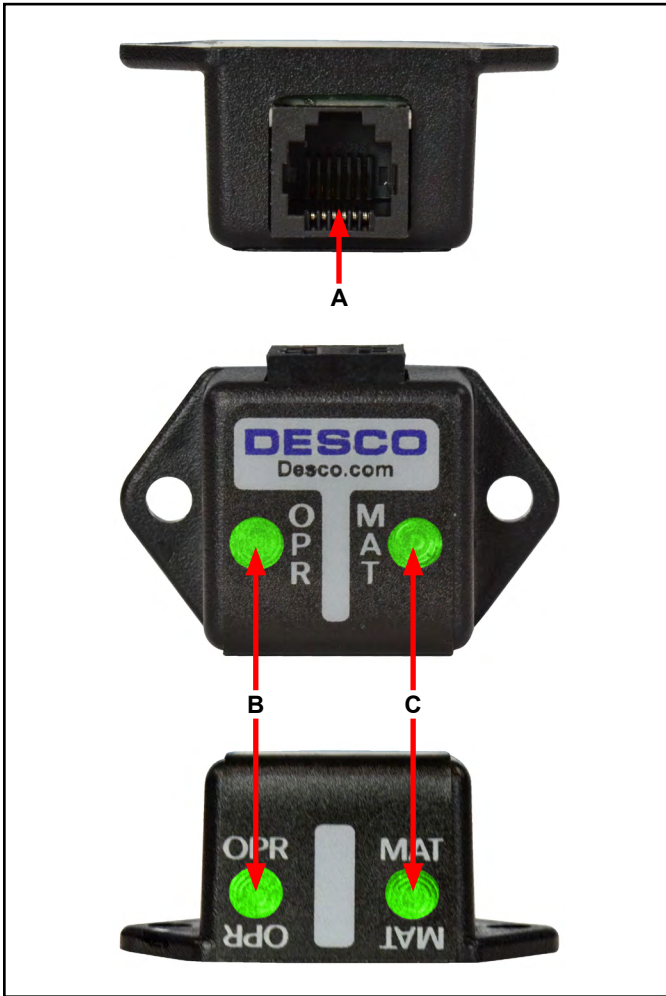

Figure 6. Remote Alarm features and components

A. Multi-Mount Monitor Jack: Connects to the Multi-Mount Monitor.

B. Operator LEDs: Illuminates green when the operator is properly grounded. Illuminates solid red and audible alarm sounds when the operator is not properly grounded.

C. Mat LEDs: Illuminates green when the worksurface is properly grounded. Illuminates red and audible alarm sounds when the worksurface is not properly grounded.

Installation

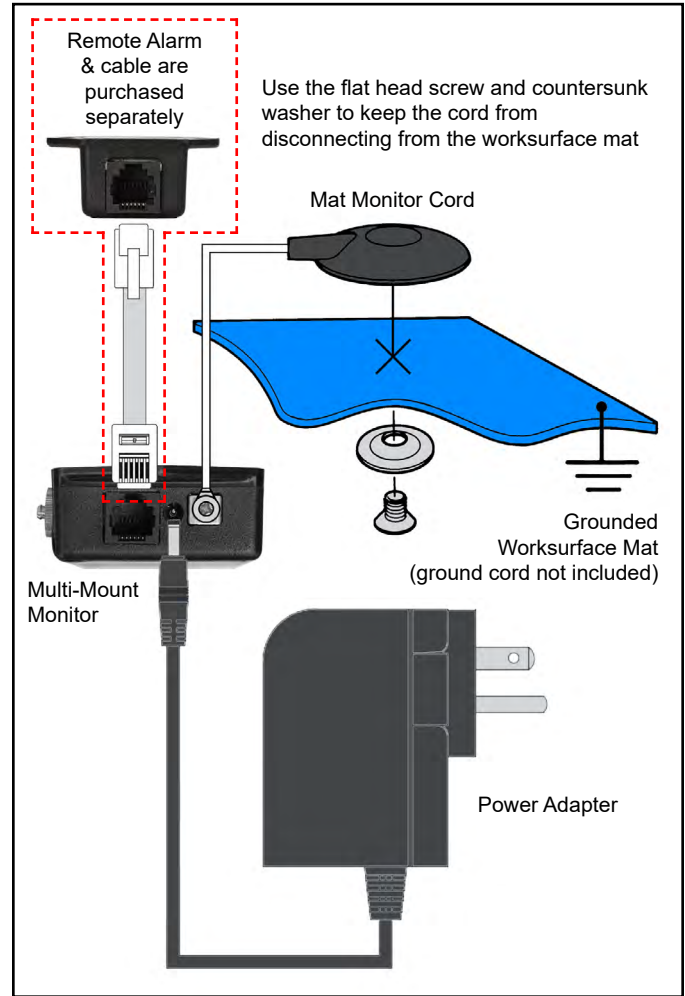

Figure 7. Installing the Multi-Mount Monitor and Remote Alarm accessory

1. Remove the Multi-Mount Monitor from the carton, and inspect for damage.
2. Locate an appropriate AC outlet near the Multi-Mount Monitor, and test it for proper wiring and grounding prior to use. The Desco AC Outlet Analyzer or similar test equipment may be used to verify the outlet's functionality. Use item number [98132](#) for 120VAC North American outlets and item number [98131](#) for 220VAC UK outlets.
3. Determine the mounting location of the Multi-Mount Monitor. Its LEDs should be visible to the operator. Secure the Multi-Mount Monitor to a surface using its mounting tabs and the included pan-head screws or dual lock fasteners.
4. Secure the ring termination of the white mat monitor cord to the mat monitor screw terminal on the side of the Multi-Mount Monitor. Ensure that the mat monitor switch is enabled if using this monitored circuit.

5. Connect the mat monitor cord from the side of the Multi-Mount Monitor to a grounded worksurface mat. Use the included countersunk washer and flat head screw to secure the cord to the grounded mat.
6. Connect the power adapter to the power jack located on the side of the Multi-Mount Monitor, and plug the power supply into the tested AC outlet.

Remote Alarm

1. Determine the mounting location of the optional [19653](#) Remote Alarm. Locate it within reach of the included remote cable. Its LEDs should be visible to the operator. Secure the Remote Alarm to a surface using its mounting tabs and the included pan-head screws or dual lock fasteners.
2. Connect the Remote Alarm to the Multi-Mount Monitor using the remote cable.

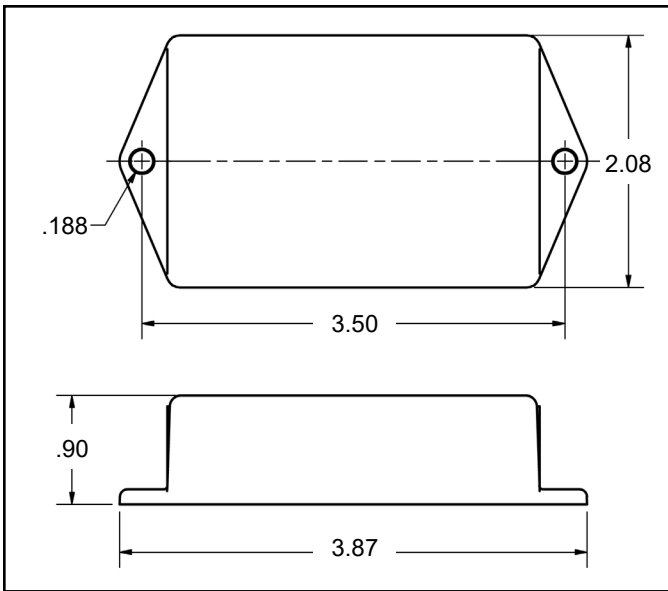

Figure 8. Mounting hole locations on the Multi-Mount Monitor (all dimensions are in inches)

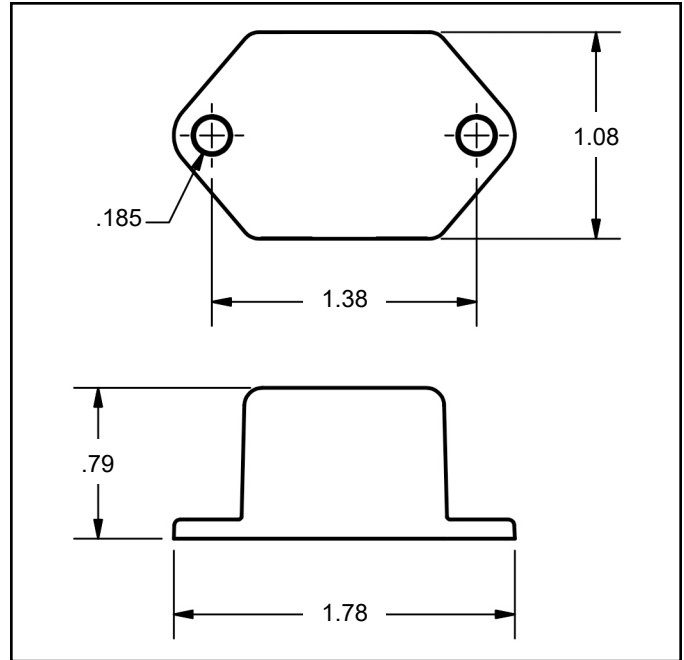

Figure 9. Mounting hole locations on the Remote Alarm (all dimensions are in inches)

10mm Park Snap and 10mm Operator Jack Adapter

The [19652](#) Multi-Mount Monitor includes an interchangeable 10mm park snap and 10mm banana jack adapter for operators who use wrist cords with 10mm terminations. Use the park snaps' knurled rims to unscrew the 4mm park snap from the monitor and install the 10mm park snap to the monitor. Plug the 10mm operator jack adapter into the monitor's operator jack.



Figure 10. Changing the park snap on the [19652](#) Multi-Mount Monitor

Operation

1. Fit the wristband snugly onto the wrist.
2. Snap the wrist cord to the wristband.
3. Plug the wrist cord into the operator jack. The green operator LED will illuminate. This indicates that the operator is properly grounded.
4. If this does not happen, examine the wrist cord for continuity or damage and the wristband to ensure that it fits securely. If you have dry skin, apply an approved dissipative hand lotion such as [Menda Reztore® ESD Hand Lotion](#).
5. When leaving the workstation, first touch the monitor's park snap. The monitor's audible alarm will disable for approximately 10 seconds. Use this time to disconnect the wrist cord from the wristband and attach it to the park snap without sounding a false alarm.
6. Upon returning to the workstation and disconnecting the wrist cord from the park snap, the monitor will provide approximately 10 seconds for the operator to reconnect the wrist cord to a worn wristband before sounding the monitor's alarm.

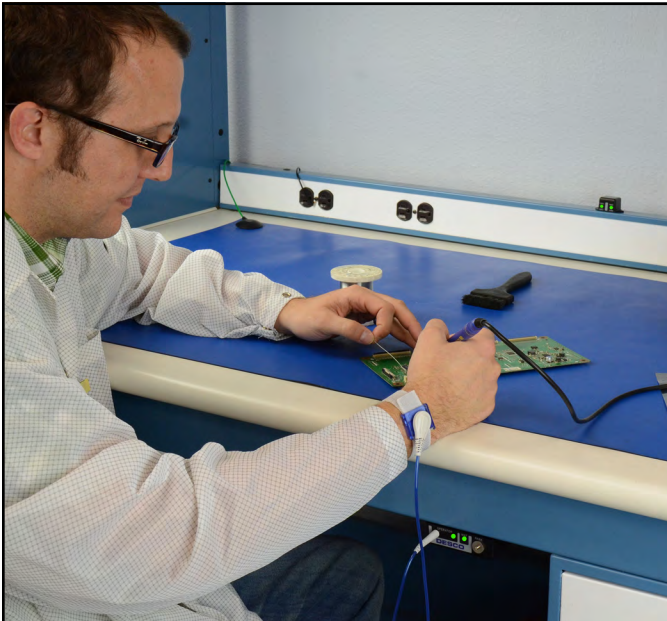

Figure 11. Using the Multi-Mount Monitor and Remote Alarm in a workbench setting



Figure 12. Using the Multi-Mount Monitor at a machine station

Calibration

Frequency of recalibration should be based on the critical nature of those ESD sensitive items handled and the risk of failure for the ESD protective equipment and materials. In general, Desco recommends that calibration be performed annually.

Use the Desco [98221](#) Wave Distortion Monitor Verification Tester to perform periodic verification (once every 6-12 months) of the Multi-Mount Monitor. The verification tester can be used to check the test limits of the Multi-Mount Monitor without removing it from the workstation.

See [TB-3074](#) for more information.



Figure 13. Desco [98221](#) Wave Distortion Monitor Verification Tester

Specifications

| | |
|--|---|
| Input Voltage and Frequency (External Adapter) | AC/DC Power Adapter Power Input: 100-240VAC, 50/60 Hz Power Output: 24VDC @ 150mA Cable Length: 5 ft. (1.5 m) |
| Operating Temperature | 50 to 95°F (10 to 35°C) |
| Environmental Requirements | Indoor use only at altitudes less than 6500 ft. (2 km) Maximum relative humidity of 80% up to 85°F (30°C) decreasing linearly to 50% @ 85°F (30°C) |
| Dimensions (Monitor) | 3.87" L x 2.09" W x .90" H (98 mm x 53 mm x 23 mm) |
| Dimensions (Remote Alarm) | 1.78" L x 1.08" W x .79" H (45 mm x 27 mm x 20 mm) |
| Weight (Monitor) | 0.14 lbs. (0.06 kg) |
| Weight (Remote Alarm) | 0.02 lbs. (0.01 kg) |
| Operator Test Range* | 500 kilohms to 10 megohms impedance |
| Worksurface Test Limit** | 10 megohms (±20%) |
| Operator Test Voltage | 1.2V peak-to-peak @ 1.2µA, open circuit |
| Worksurface Test Voltage | 5 to 7.5V, open circuit |
| Alarm Response Time | <50 ms |
| Country of Origin | United States of America |

*This cannot be verified with standard DC test equipment. The continuous monitor is an impedance sensing device, and the limits are determined by the magnitude and angle of the impedance.

**The worksurface mat must have a conductive layer such as Dual Layer Rubber or Dissipative 3-Layer Vinyl with conductive buried layers. Desco workstation monitors are not recommended for use with homogeneous matting.

ANSI/ESD S20.20 requires the use of a surface resistance meter for periodic verification of a worksurface's resistance-to-ground (Rtg). Constant monitors may not be used as a substitute for this requirement.

Limited Warranty, Warranty Exclusions, Limit of Liability and RMA Request Instructions

See the Desco Warranty - Desco.com/Limited-Warranty.aspx