

**PLEASE CHECK WWW.MOLEX.COM FOR LATEST PART INFORMATION**

**Part Number:** [19606-0006](#)  
**Status:** **Active**  
**Description:** Avikrimp™ Fully Insulated Quick Disconnect, Female, for 10-12 AWG Wire, Mylar Tape

**Documents:**

[Drawing \(PDF\)](#) [Product Specification PS-19902-015 \(PDF\)](#)  
[Product Specification PS-19902-014 \(PDF\)](#) [RoHS Certificate of Compliance \(PDF\)](#)

**Agency Certification**

CSA LR18689  
 UL E79133

**General**

Product Family Quick Disconnects  
 Series [19606](#)  
 Crimp Quality Equipment Yes  
 Product Name Avikrimp™  
 Type Quick Disconnect  
 UPC 800753117990

**Physical**

Barrel Type Closed  
 Flammability 94V-2  
 Gender Female  
 Glow-Wire Compliant No  
 Insulation Nylon (PA)  
 Lock to Mating Part None  
 Material - Metal Brass  
 Material - Plating Mating Tin  
 Material - Plating Termination Tin  
 Net Weight 1.713g  
 Orientation Straight  
 Packaging Type Adhesive Tape on Reel  
 Plating min - Mating 2.540µm  
 Plating min - Termination 2.540µm  
 Polarized to Mating Part No  
 Tab Thickness 0.81mm  
 Tab Width 6.35mm  
 Temperature Range - Operating -65°C to +105°C  
 Termination Interface: Style Crimp or Compression  
 Wire Insulation Diameter 5.84mm max.  
 Wire Size AWG 10, 12  
 Wire Size mm² 3.30 - 5.00

**Electrical**

Voltage - Maximum 300V

**Material Info**

Old Part Number C-5293T

**Reference - Drawing Numbers**

Product Specification PS-19902-014, PS-19902-015  
 Sales Drawing SD-19606-003

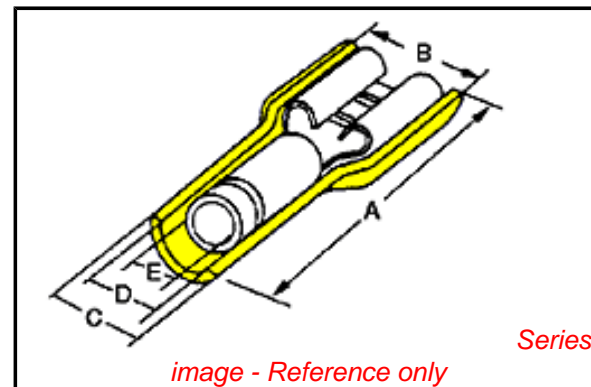

**EU RoHS**

**ELV and RoHS Compliant**  
**REACH SVHC**  
 Not Reviewed  
**Low-Halogen Status**  
 Not Reviewed

**China RoHS**



**Need more information on product environmental compliance?**

Email [productcompliance@molex.com](mailto:productcompliance@molex.com)  
 For a multiple part number RoHS Certificate of Compliance, [click here](#)

Please visit the [Contact Us](#) section for any non-product compliance questions.

**Search Parts in this Series**

19606Series

**Application Tooling | FAQ**

*Tooling specifications and manuals are found by selecting the products below. Crimp Height Specifications are then contained in the Application Tooling Specification document.*

**Global**

Description	Product #
ATP Perishable Tool Kit used in ATP presses that process product on tape	<a href="#">0190270019</a>
Mini-Mac™ Applicator	<a href="#">0638852100</a>

**PLEASE CHECK [WWW.MOLEX.COM](http://WWW.MOLEX.COM) FOR LATEST PART INFORMATION**