

5/8 ROUND FEMALE STANDOFFS

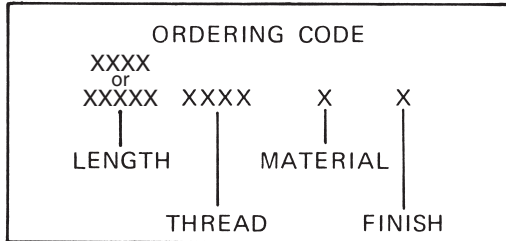
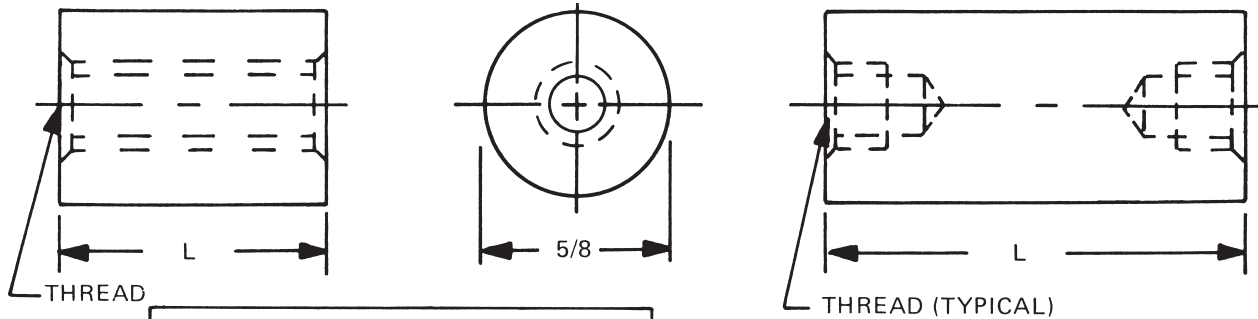

See page 10 for thread depth chart
 See page 9 for finish codes
 For non-standard parts contact Sales Office

LENGTH	PART NO.
3/32	1946A
1/8	1946
5/32	1946T
3/16	1947
7/32	1947T
1/4	1948
9/32	1948T
5/16	1949
11/32	1949T
3/8	1950
13/32	1950T
7/16	1951
15/32	1951T
1/2	1952
17/32	1952T
9/16	1953
19/32	1953T
5/8	1954
21/32	1954T
11/16	1955
23/32	1955T
3/4	1956
25/32	1956T
13/16	1957
27/32	1957T
7/8	1958
29/32	1958T

LENGTH	PART NO.
15/16	1959
31/32	1959T
1"	1960
1-1/16	1961
1-1/8	1962
1-3/16	1963
1-1/4	1964
1-5/16	1965
1-3/8	1966
1-7/16	1967
1-1/2	1968
1-9/16	1969
1-5/8	1970
1-11/16	1971
1-3/4	1972
1-13/16	1973
1-7/8	1974
1-15/16	1975
2"	1976
2-1/8	1977
2-1/4	1978
2-3/8	1979
2-1/2	1980
2-5/8	1981
2-3/4	1982
2-7/8	1983
3"	1984

LENGTH	PART NO.
3-1/4	1985
3-1/2	1986
3-3/4	1987
4"	1988
4-1/4	1989
4-1/2	1990
4-3/4	1991
5"	1992
5-1/4	1993
5-1/2	1994
5-3/4	1995
6"	1996
6-1/4	1997
6-1/2	1998
6-3/4	1999
7"	2000
7-1/4	2001
7-1/2	2002
7-3/4	2003
8"	2004
8-1/4	2005
8-1/2	2006
8-3/4	2007
9"	2008
9-1/4	2009
9-1/2	2010
9-3/4	2011
10"	2012

THREAD	CODE
8-32	832
10-32	1032
12-24	1224
1/4-20	2520
5/16-18	3118
3/8-16	3716
7/16-14	4314

MATERIAL	CODE	RoHS
Aluminum	AL	YES
Brass	B	YES
Stainless Steel	SS	YES
Steel	S	YES
Nylon	N	YES
Phenolic	PH	YES



RAF ELECTRONIC
HARDWARE

95 Silvermine Road, Seymour, Ct. 06483 Phone: 203-888-2133 Fax: 203-888-9860
 e-mail : info@rafhdwe.com Web: www.rafhdwe.com

