

**NOTES:**

① MATERIAL COPPER (STOCK TKN.  $\frac{.040}{1.02}$ )  
 PLATING ELECTRO TIN (.0003 MIN.)

FILE NO. C - CD - 105 - 02

**STUD SIZES: ( $\pm .005$ )**

- 02 = .094
- 04 = .119
- 06 = .146
- 08 = .173
- 10 = .198
- 14 = .265
- 56 = .328
- 38 = .390

"UL" LISTING \*E32244  
 "CSA" LISTING #18689

ALL DIMENSIONS =  $\frac{\text{INCHES}}{\text{MM}}$

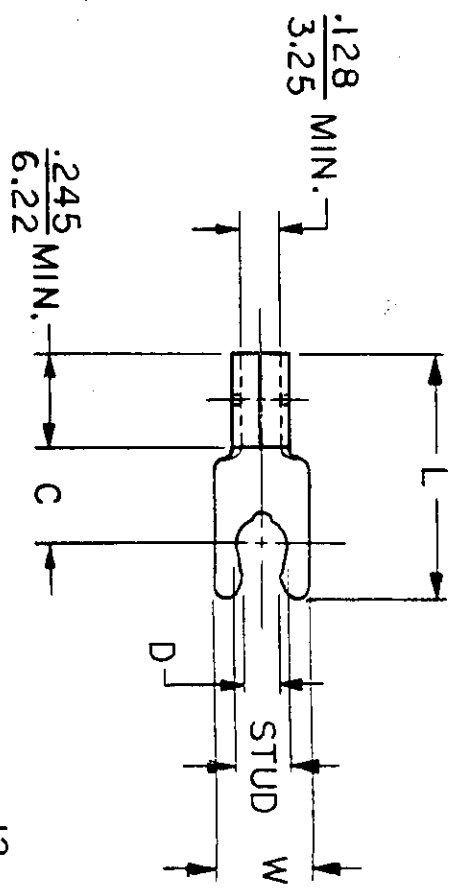

WIRE SIZE: 12-10 AWG  
 4.0-6.0 MM<sup>2</sup>

PART NUMBER	"W" ±.010	"C" MIN.	"L" MAX.	"D" ±.005	AVAILABLE STUD SIZES	DIMENSIONAL TOLERANCES UNLESS OTHERWISE SPECIFIED	
						FRAC.	DEC.
C-1710-	$\frac{.250}{6.35}$	$\frac{.230}{5.84}$	$\frac{.664}{16.87}$	$\frac{.105}{2.67}$	05 ( $\frac{.127}{3.23}$ )		
C-1710-	$\frac{.250}{6.35}$	$\frac{.230}{5.84}$	$\frac{.664}{16.87}$	$\frac{.114}{2.90}$	06		
C-1711-	$\frac{.375}{9.53}$	$\frac{.261}{6.63}$	$\frac{.725}{18.43}$	$\frac{.139}{3.53}$	08		
C-1712-	$\frac{.406}{10.31}$	$\frac{.261}{6.63}$	$\frac{.773}{19.63}$	$\frac{.156}{3.96}$	10		

SCALE:	NTS	DATE	TITLE:
DRWN. BY:	Ko	10-17-84	SNAP SPADE SHORT TONGUE TERMINAL
CHKD. BY:	GZ	11.2.84	KRIMPITE 100-SERIES
APPRD. BY:			

DWG. NO.	A	CUSTOMER DWG.
----------	---	---------------

