

NOTES:

- ① MAT'L : COPPER (STOCK TKN. .031)
- PLATING : ELECTRO-TIN (.0003 MIN.)

STUD SIZES: ($\pm .005$)

- 02 = .094
- 04 = .119
- 06 = .146
- 08 = .173
- 10 = .198
- 14 = .265
- 56 = .328
- 38 = .390

"UL" LISTING #E32244
 "CSA" LISTING #18689

ALL DIMENSIONS = $\frac{\text{INCHES}}{\text{MM}}$

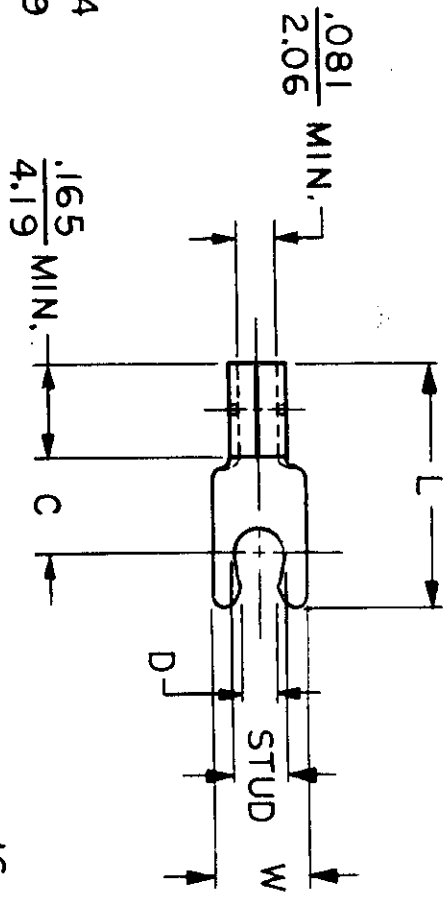

WIRE SIZE: 16-14 AWG
 1.0-2.5MM²

PART NUMBER	"W"	"C"	"L"	"D"	AVAILABLE STUD SIZES	DIMENSIONAL TOLERANCES UNLESS OTHERWISE SPECIFIED	
						±.010	REFERENCE
BB-1707-	$\frac{.250}{6.35}$	$\frac{.230}{5.84}$	$\frac{.585}{14.86}$	$\frac{.105}{2.67}$	05 ($\frac{.127}{3.23}$)	SCALE: NTS	DATE: 10-19-84
BB-1707-	$\frac{.250}{6.35}$	$\frac{.230}{5.84}$	$\frac{.585}{14.86}$	$\frac{.114}{2.90}$	06	DRWN. BY: <i>Ys</i>	CHKD. BY: <i>GZ</i>
BB-1708-	$\frac{.375}{9.53}$	$\frac{.261}{6.63}$	$\frac{.646}{16.41}$	$\frac{.139}{3.53}$	08	APPRD. BY:	11.2.84
BB-1709-	$\frac{.406}{10.31}$	$\frac{.261}{6.63}$	$\frac{.694}{17.63}$	$\frac{.156}{3.96}$	10	TITLE: SNAP SPADE SHORT TONGUE TERMINAL KRIMPTITE 100-SERIES	
						DWG. NO. A CUSTOMER DWG.	