

10	9	8	7	6	5	4	3	2	19025							
LOOSE PC MATERIAL NO.	LOOSE PC ENG. NO.	ON TAPE MAT'L NO.	ON TAPE ENG. NO.	WIRE RANGE	TAB SIZE REFERENCE	COLOR	ID MIN	B REF	MWID	L MAX	W ± 0.05 0.13	A MIN	H MAX	C ± 0.07 0.18	TERMINAL MAT'L THICKNESS - REF	TERMINAL FINISH
190250001	AMCT-5	190250004	AMCT-5T	22-18AWG (0.38-.96mm ²)	.250x.032 (6.35x0.81)	RED	.054/1.37	.546/13.87	.138/3.51	1.00/25.4	.250/6.35	.30/7.6	.14/3.6	.075/1.91	BRASS, .032/0.81	ZINC CHROMATE
190250007	MCT-5	190250010	MCT-5T	16-14AWG (1.23-1.94mm ²)	.250x.032 (6.35x0.81)	BLUE	.081/2.06	.546/13.87	.165/4.19	1.00/25.4	.250/6.35	.30/7.6	.14/3.6	.075/1.91	BRASS, .032/0.81	ZINC CHROMATE
190250005	CMCT-5	190250006	CMCT-5T	12-10AWG (3.09-5.01mm ²)	.250x.032 (6.35x0.81)	YELLOW	.128/3.25	.669/16.99	.225/5.71	1.18/30.0	.250/6.35	.30/7.6	.14/3.6	.075/1.91	BRASS, .032/0.81	ZINC CHROMATE
190250002	AMCT-57	190250003	AMCT-57T	22-18AWG (0.38-.96mm ²)	.187x.020 (4.75x0.51)	RED	.054/1.37	.546/13.87	.138/3.51	.82/20.83	.187/4.75	.24/6.1	.13/3.3	.055/1.40	BRASS, .020/0.51	ZINC CHROMATE
190250008	MCT-57	190250009	MCT-57T	16-14AWG (1.23-1.94mm ²)	.187x.020 (4.75x0.51)	BLUE	.081/2.06	.546/13.87	.165/4.19	.82/20.83	.187/4.75	.24/6.1	.13/3.3	.055/1.40	BRASS, .020/0.51	ZINC CHROMATE

(A) (ENTIRE CHART)

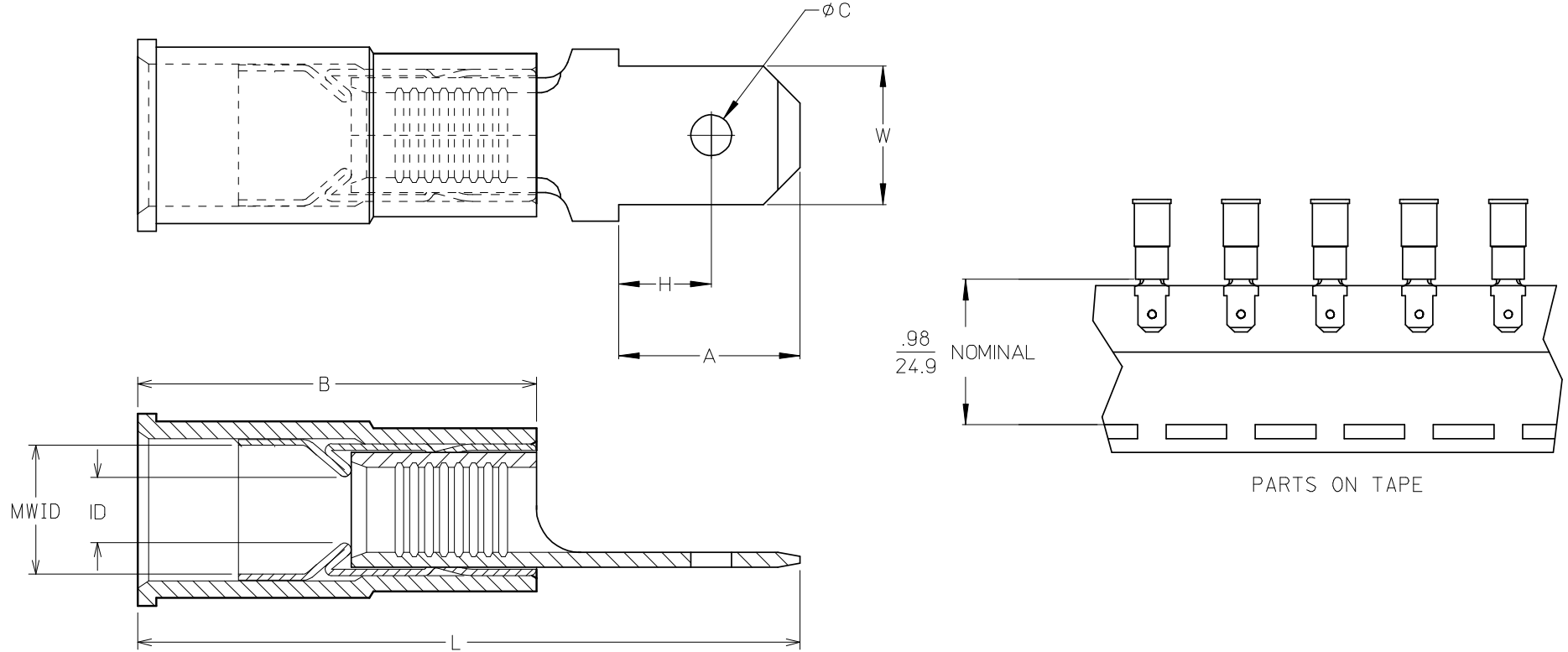

(A) (ALL NOTES)

NOTES:

1. TERMINAL MATERIAL & FINISH: SEE CHART
2. INSULATION MATERIAL: NYLON
3. FERRULE:
MATERIAL: BRASS
FINISH: TIN
4. TAB DIMENSIONS PER UL310 SPECIFICATIONS.
5. PART IS ROHS COMPLIANT.
6. MWID = MAXIMUM WIRE INSULATION DIAMETER

REDWN W/MATL & FIN CHG EC NO: ETC2007-0081 DRWN:EHILE 2008/01/28 CHKD:MACNEIL 2008/01/28 APPR:JMACNEIL 2008/02/13 REV A	QUALITY SYMBOLS ▽=0 ▽=0	GENERAL TOLERANCES (UNLESS SPECIFIED)		DIMENSION STYLE IN/MM (A)	SCALE ---	DESIGN UNITS INCH	THIRD ANGLE PROJECTION	
		4 PLACES ±--- ±---	mm INCH	DRAWN BY RCM	DATE 1994/07/06	TITLE MALE QUICK DISCONNECT, AVIKRIMP		
		3 PLACES ±--- ±---		CHECKED BY JM	DATE 1994/07/06	MOLEX INCORPORATED		
		2 PLACES ±--- ±---		APPROVED BY FP	DATE 1994/07/06	MATERIAL NO. SEE CHART	DOCUMENT NO. SD-19025-002	SHEET NO. 1 OF 1
1 PLACE ±--- ±---		ANGULAR ±---°		DRAFT WHERE APPLICABLE MUST REMAIN WITHIN DIMENSIONS				
THIS DRAWING CONTAINS INFORMATION THAT IS PROPRIETARY TO MOLEX INCORPORATED AND SHOULD NOT BE USED WITHOUT WRITTEN PERMISSION								

10	9	8	7	6	5	4	3	2	19025							
LOOSE PC MATERIAL NO.	LOOSE PC ENG. NO.	ON TAPE MAT'L NO.	ON TAPE ENG. NO.	WIRE RANGE	TAB SIZE REFERENCE	COLOR	ID MIN	B REF	MWID	L MAX	W ± 0.05 0.13	A MIN	H MAX	C ± 0.07 0.18	TERMINAL MAT'L THICKNESS - REF	TERMINAL FINISH
190250001	AMCT-5	190250004	AMCT-5T	22-18AWG (0.38-.96mm ²)	.250x.032 (6.35x0.81)	RED	.054/1.37	.546/13.87	.138/3.51	1.00/25.4	.250/6.35	.30/7.6	.14/3.6	.075/1.91	BRASS, .032/0.81	ZINC CHROMATE
190250007	MCT-5	190250010	MCT-5T	16-14AWG (1.23-1.94mm ²)	.250x.032 (6.35x0.81)	BLUE	.081/2.06	.546/13.87	.165/4.19	1.00/25.4	.250/6.35	.30/7.6	.14/3.6	.075/1.91	BRASS, .032/0.81	ZINC CHROMATE
190250005	CMCT-5	190250006	CMCT-5T	12-10AWG (3.09-5.01mm ²)	.250x.032 (6.35x0.81)	YELLOW	.128/3.25	.669/16.99	.225/5.71	1.18/30.0	.250/6.35	.30/7.6	.14/3.6	.075/1.91	BRASS, .032/0.81	ZINC CHROMATE
190250002	AMCT-57	190250003	AMCT-57T	22-18AWG (0.38-.96mm ²)	.187x.020 (4.75x0.51)	RED	.054/1.37	.546/13.87	.138/3.51	.82/20.83	.187/4.75	.24/6.1	.13/3.3	.055/1.40	BRASS, .020/0.51	ZINC CHROMATE
190250008	MCT-57	190250009	MCT-57T	16-14AWG (1.23-1.94mm ²)	.187x.020 (4.75x0.51)	BLUE	.081/2.06	.546/13.87	.165/4.19	.82/20.83	.187/4.75	.24/6.1	.13/3.3	.055/1.40	BRASS, .020/0.51	ZINC CHROMATE

(A) (ENTIRE CHART)

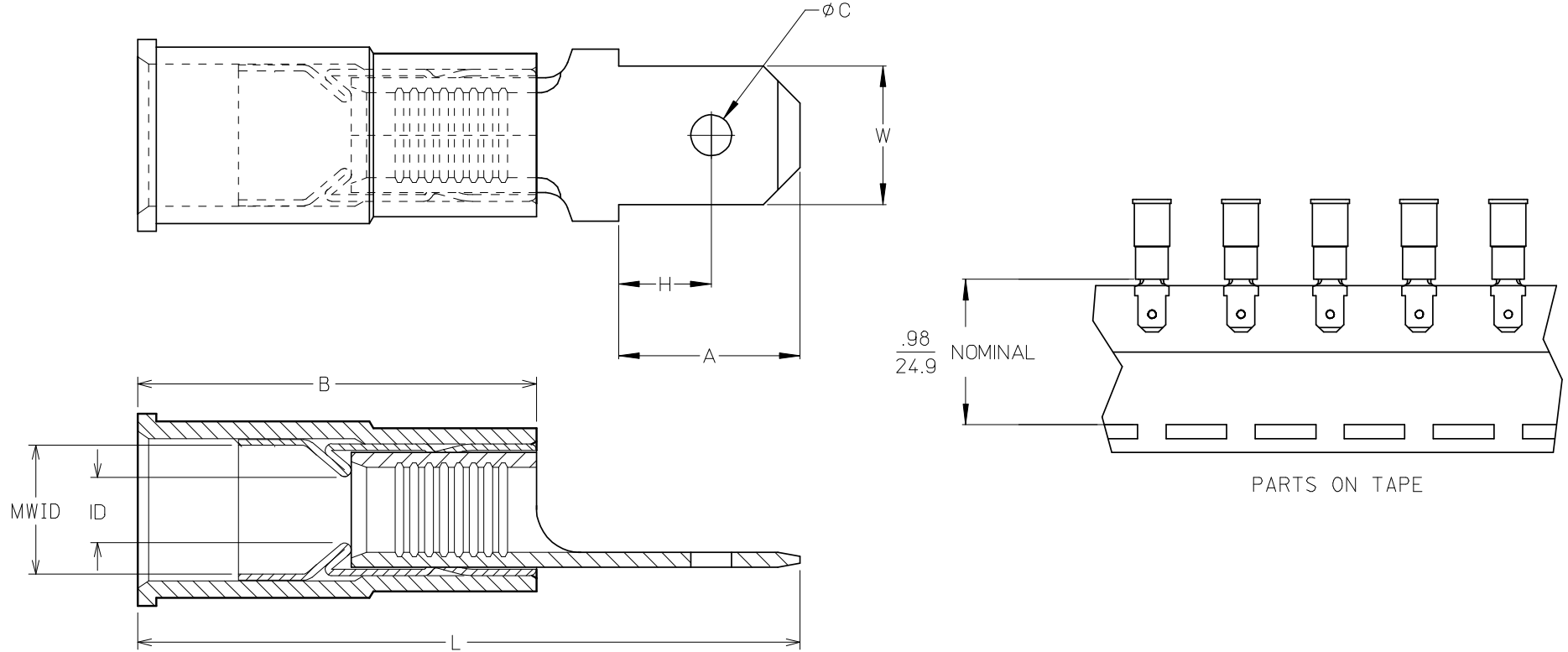

(A) (ALL NOTES)

NOTES:

1. TERMINAL MATERIAL & FINISH: SEE CHART
2. INSULATION MATERIAL: NYLON
3. FERRULE:
MATERIAL: BRASS
FINISH: TIN
4. TAB DIMENSIONS PER UL310 SPECIFICATIONS.
5. PART IS ROHS COMPLIANT.
6. MWID = MAXIMUM WIRE INSULATION DIAMETER

REDWN W/MATL & FIN CHG EC NO: ETC2007-0081 DRWN:EHILE 2008/01/28 CHKD:MACNEIL 2008/01/28 APPR:JMACNEIL 2008/02/13 REV A	QUALITY SYMBOLS	GENERAL TOLERANCES (UNLESS SPECIFIED)	DIMENSION STYLE	SCALE	DESIGN UNITS	THIRD ANGLE PROJECTION																		
	$\nabla=0$ $\sphericalangle=0$	<table border="1"> <thead> <tr> <th></th> <th>mm</th> <th>INCH</th> </tr> </thead> <tbody> <tr> <td>4 PLACES</td> <td>±---</td> <td>±---</td> </tr> <tr> <td>3 PLACES</td> <td>±---</td> <td>±---</td> </tr> <tr> <td>2 PLACES</td> <td>±---</td> <td>±---</td> </tr> <tr> <td>1 PLACE</td> <td>±---</td> <td>±---</td> </tr> <tr> <td colspan="3">ANGULAR ±---°</td> </tr> </tbody> </table>		mm	INCH	4 PLACES	±---	±---	3 PLACES	±---	±---	2 PLACES	±---	±---	1 PLACE	±---	±---	ANGULAR ±---°			IN/MM (A)	---	INCH	
		mm	INCH																					
	4 PLACES	±---	±---																					
3 PLACES	±---	±---																						
2 PLACES	±---	±---																						
1 PLACE	±---	±---																						
ANGULAR ±---°																								
	DRAWN BY RCM	DATE 1994/07/06	TITLE MALE QUICK DISCONNECT, AVIKRIMP																					
	CHECKED BY JM	DATE 1994/07/06	MOLEX INCORPORATED																					
	APPROVED BY FP	DATE 1994/07/06	MATERIAL NO. SEE CHART	DOCUMENT NO. SD-19025-002	SHEET NO. 1 OF 1																			
	DRAFT WHERE APPLICABLE MUST REMAIN WITHIN DIMENSIONS																							
	THIS DRAWING CONTAINS INFORMATION THAT IS PROPRIETARY TO MOLEX INCORPORATED AND SHOULD NOT BE USED WITHOUT WRITTEN PERMISSION																							