

Multifunction DAQ Accessory and Cable Selection Guides

NI Cable Design Advantages

The cables designated “EP” are the most commonly used data acquisition device cables. Each type of cable is designed to work specifically with the NI Multifunction DAQ devices to preserve signal integrity with these technologies:

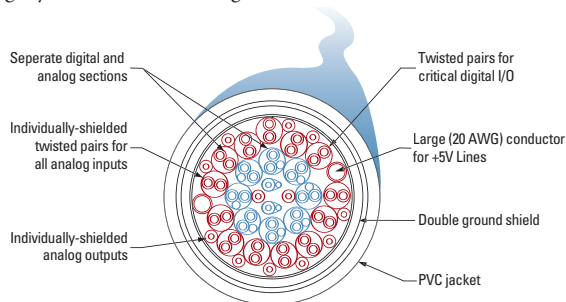

Figure 1. SH68-68-EP Cable

Accessories

Page

Cables	
Ribbon.....	3
Shielded.....	3
RTSI Bus.....	4
Signal Conditioning	4
Connector Blocks	4
BNC.....	4
Screw Terminals.....	4
Custom Connectivity	5

Use the following tables to choose the most appropriate cables and accessories.

M Series	Feature	Connect to...	Connector ¹	Cable	Cable Adapter	Accessory
NI 6220 NI 6224	Noise-reducing	SCC portable signal conditioning	0 only	SHC68-68-EPM	–	See page 168
NI 6221 NI 6229	Noise-reducing	SCXI high-performance signal-conditioning	0 only	SHC68-68-EPM	–	See page 183
NI 6250 NI 6254	Noise-reducing	Screw terminals	0 or 1	SHC68-68-EPM	–	SCB-68 or TBX-68
NI 6251 NI 6259	Noise-reducing	BNC terminal block	0 or 1	SHC68-68-EPM	–	BNC-2110,
NI 6280 NI 6284	Noise-reducing	50-pin connector	0 or 1	SHC68-68-EPM	68M-50F MIO	Custom-built or third-party
NI 6281 NI 6289	Low-cost	Screw terminals	0 or 1	SHC68-68-S	–	CB-68LP of CB-68LPR
	Low-cost	50-pin connector	0 or 1	SHC68-68-S	68M-50F MIO	Custom-built or third-party

¹Connector 0 is available on all M Series devices. 0 and 1 are available on NI 62x4 and 62x9 devices.

Product	Feature	Connect to...	Cable	Accessory
68-pin E Series (except DAQCards):	Noise-reducing	SCC portable signal conditioning	SH68-68-EP	See page 168
NI 6070E NI 6032E	Noise-reducing	SCXI high-performance signal-conditioning	SH68-68-EP	See page 183
NI 6052E NI 6030E	Noise-reducing	Screw terminals	SH68-68-EP	SCB-68 or TBX-68
NI 6040E NI 6024E	Noise-reducing	BNC terminal block	SH68-68-EP	BNC-2110, BNC-2120, or BNC-2190
NI 6036E NI 6023E	Noise-reducing	50-pin connector	SH6850	Custom-built or third-party
NI 6034E	Low-cost	Screw terminals	RC68-68	CB-68LP of CB-68LPR
	Low-cost	50-pin connector	RC68-68	Custom-built or third-party
100-pin E Series	Noise-reducing	Screw terminals	SH100100	SCB100
NI 6071E	Noise-reducing	Screw terminals	SH1006868	2 SCB-68
NI 6033E	Noise-reducing	BNC terminal block	SH1006868	BNC-2115 and BNC-2110, BNC-2120, or BNC-2190
NI 6031E	Noise-reducing	50-pin connector	SH1006868	Custom-built or third-party
NI 6025E	Low-cost	Screw terminals	SH1006868	CB68LP and/or CB68LPR
	Low-cost	50-pin connector	SH1006868	Custom-built or third-party
E Series DAQCards	Noise-reducing	SCC portable signal conditioning	SHC68-68-EP	See page 168
NI DAQCard-6062E	Noise-reducing	SCXI high-performance signal-conditioning	SHC68-68-EP	See page 183
NI DAQCard-6036E	Noise-reducing	Screw terminals	SHC68-68-EP	SCB-68 or TBX-68
NI DAQCard-6024E	Noise-reducing	BNC terminal block	SHC68-68-EP	BNC-2210, BNC-2120, or BNC 2190
	Noise-reducing	50-pin connector	SHC68-68-EP	Custom-built or third-party
	Low-cost	Screw terminals	RC68-68	CB-68LP of CB-68LPR
	Low-cost	50-pin connector	RC68-68	Custom-built or third-party
S Series (except NI 6143)	Noise-reducing	Screw terminals	SH68-68-EP	SCB-68
NI 6133 NI 6115	Noise-reducing	Screw terminals ¹	N/A	TB-2705
NI 6132 NI 6111	Noise-reducing	BNC terminal block	SH68-68-EP	BNC-2110
NI 6120 NI 6110	Low-cost	Screw terminals	R6868	CB-68LP
S Series	Noise-reducing	Screw terminals	SHC68-68-EP	SCB-68
NI 6143	Noise-reducing	BNC terminal block	SHC68-68-EP	BNC-2110
	Low-cost	Screw terminals	RC68-68	CB-68LP
B Series (PCI Only)²	Noise-reducing	SCC portable signal conditioning	SH68-68-EP	See page 168
NI 6013	Noise-reducing	Screw terminals	SH68-68-EP	SCB-68
NI 6014	Noise-reducing	BNC terminal block	SH68-68-EP	BNC-2110, BNC-2120, or BNC 2190
	Low-cost	Screw terminals	R6868	CB-68LP

¹PXI only. ²USB B Series devices require no accessories.

Multifunction DAQ Accessories and Cables

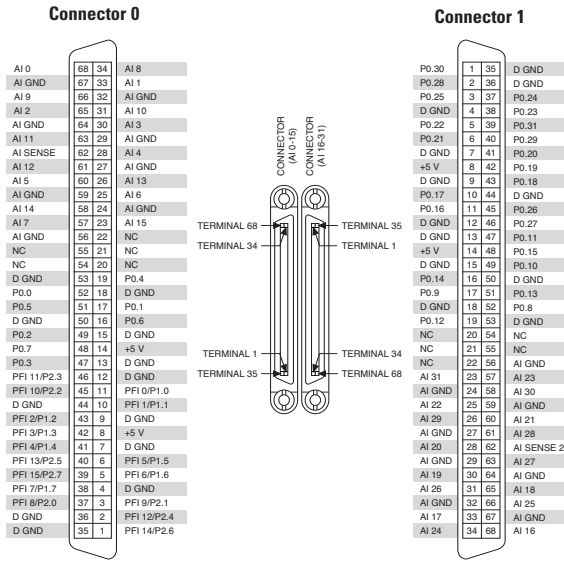
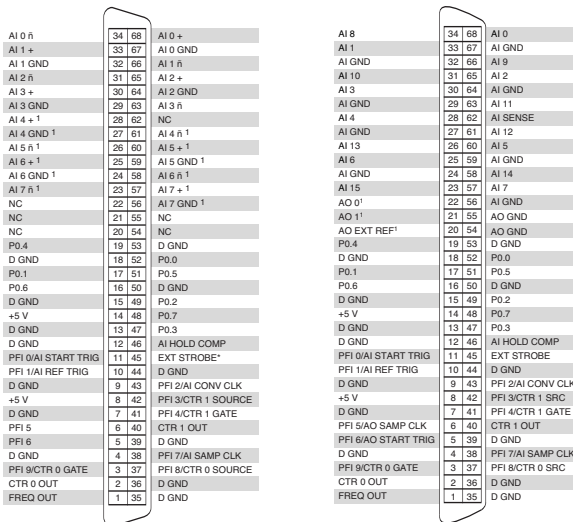

Figure 2. M Series Device Connectors



NC = No Connect
* NC on NI 6122/6132

Figure 3. S Series Devices Connector

Figure 4. I/O Connector for 16-Channel E Series and B Series Devices, except NI 6025E

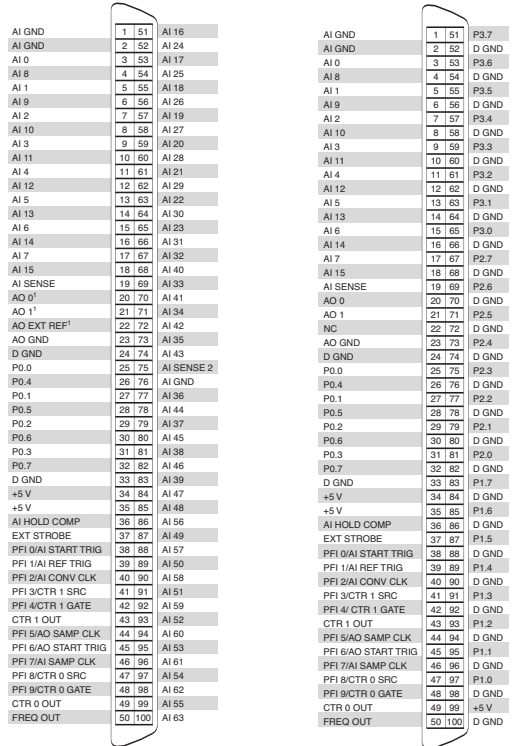

Figure 5. I/O Connector for 64-Channel E Series Devices

Figure 6. I/O Connector for the NI 6025E Device

Multifunction DAQ Accessories and Cables

Ribbon I/O Cables

R6868 – A low-cost, 68-conductor flat ribbon cable terminated with two 68-pin connectors. Use this cable to connect a 68-pin E Series, S Series (except NI 6143), or B Series multifunction DAQ device to 68-pin accessories.

1 m182482-01

RC68-68 – A 68 conductor ribbon cable that connects a DAQCard, an M Series device, or an NI 6143 directly to 68-pin accessories. Two RC68-68 cables can be used together in adjacent PCMCIA slots or adjacent connectors on 2-connector M Series devices.

0.25 m.....187252-0R25

1 m187252-01

R1005050 – Connects 100-pin E Series devices, to standard 50-pin third-party or custom connectors.

1 m182762-01

2 m182762-02

R6850 – Combines a 68F-50M cable adapter and a standard 50-pin cable with female connectors on both ends. It is designed to adapt a 68-pin E Series, S Series, or B Series multifunction DAQ device to a third-party or custom 50-pin accessory.

1 m776842-01

Shielded I/O Cables

SHC68-68-EPM – A high-performance shielded 68-conductor cable terminated with a VHDCI 68-pin male connector at one end and a 68-pin female 0.050 D-type connector at the other end for connecting M Series DAQ devices to standard 68-pin accessories.

0.5 m.....192061-0R5

1 m192061-01

2 m192061-02

SHC68-68-S – A low-cost cable for connecting M Series DAQ devices to 68-pin accessories and signal conditioning systems. It features individually twisted cable pairs, but does not have shields between the analog and digital signals. For improved noise rejection, consider the SHC68-68-EPM.

1 m191945-01

2 m191945-02

SH68-68-EP – A shielded 68-conductor cable terminated with two 68-pin female 0.050 series D-type connectors. This cable connects to 68-pin E Series, S Series, and B Series devices. If you need a right-angle connector, the SH68-68R1-EP shielded cable is electrically equivalent.

1 m184749-01

2 m184749-02

Please call for other length options.

SH68-68R1-EP – A shielded 68-conductor cable for use with 68-pin E Series, S Series (except NI 6143), and B Series devices. One end terminates with a 68-pin female 0.050 series D-type connector and the other end terminates with a right-angle 68-pin female 0.050 series D-type connector.

1 m187051-01

SH100100 – A shielded 100-conductor cable terminated with 100-pin male 0.050 series D-type connectors. This cable connects the 100-pin E Series devices to 100-pin accessories.

1 m182853-01

2 m182853-02

SH1006868 – A shielded cable that connects to 100-pin E Series devices and terminates with two female 68-pin 0.050 series D-type connectors.

1 m182849-01

2 m182849-02

SHC68-68-EP and SHC68U-68-EP – Shielded 68-conductor cables terminated with a VHDCI 68-pin male connector at one end and a 68-pin female 0.050 series D-type connector at the other. When using two E Series DAQCards in adjacent slots, use one SHC68-68-EP and one SHC68U-68-EP.

SHC68-68-EP

0.5 m186838-0R5

1 m186838-01

SHC68U-68-EP

0.5 m187406-0R5

1 m187406-01



R6868



RC68-68



SH68-68R1-EP



SH100100



SH1006868



SHC68-68-EP and
SHC68U-68-EP

Multifunction DAQ Accessories and Cables

SH6850 – A shielded cable that connects a 68-pin E Series, S Series (except NI 6143), or B Series multifunction DAQ product to a third party or custom standard 50-pin accessory. The cable provides a screw-latching 68-pin female connector on one side and a standard 50-pin female connector on the other side.

1 m776784-01
2 m776784-02

68M-50F – Adapter that connects a 68-pin NI shielded cable to a standard 0.1 by 0.1 in. 50-pin connector on third-party or custom accessories. Use the 68M-50F MIO with the SHC68-68-EPM, SH68-68-EP, SHC68-68-EP, SHC68U-68-EP, or the multifunction I/O portion of the SH1006868. Use The 68M-50F Extended I/O cable adapter for the extended I/O portion of the SH1006868.

68M-50F MIO184670-01

RTSI Bus Cables – Connect timing and synchronization signals among data acquisition, M Series, E Series, S Series, vision, motion, and CAN boards for PCI. For systems using long and short boards, order the extended RTSI cable.

2 boards776249-02
3 boards776249-03
4 boards776249-04
5 boards776249-05
Extended, 5 boards.....777562-05

Signal Conditioning

SCC – A portable modular signal conditioning system consisting of modules that plug into a low-profile shielded carrier. Choose from a variety of signal conditioning options including sensor, input, isolation, and filtering modules. SCC is compatible with M Series, E Series, and some B Series and portable devices.

SCC Signal Conditioning.....See page 168

SCXI – A high-performance modular signal conditioning platform that provides a front end to your M Series or E Series DAQ device. You can expand your analog inputs to 3,072 channels. SCXI offers a variety of modules for sensor conditioning, amplification, filtering, and other modules.

SCXI Signal ConditioningSee page 183

Connector Blocks

BNC-2100 Series – Shielded connector blocks with signal-labeled BNC connectors for easy connectivity of your I/O signals. The BNC-2110 and BNC-2120 work with all E Series, M Series, S Series, and B Series multifunction DAQ or analog output devices. The BNC-2120 also provides a function generator, quadrature encoder, temperature reference, thermocouple connector, and LED so that you can test the functionality of your hardware. The BNC-2115 has 24 BNC inputs for connecting to the extended I/O channels of 100-pin E Series DAQ devices.

BNC-2110.....777643-01

Dimensions – 20.3 by 11.2 by 5.5 cm (8.0 by 4.4 by 2.2 in.)

BNC-2115.....777807-01

Dimensions – 20.3 by 11.2 by 5.5 cm (8.0 by 4.4 by 2.2 in.)

BNC-2120.....777960-01

Dimensions – 26.7 by 11.2 by 6.0 cm (10.5 by 4.4 by 2.4 in.)

BNC-2090 – A shielded, rack-mountable adapter with 22 signal-labeled BNC connectors and 28 spring terminal blocks to simplify connections to your I/O signals. The BNC-2090 includes component locations for passive signal conditioning and connects to any 68-pin M Series, S Series, E Series, or B Series DAQ device.

BNC-2090.....777270-01

Dimensions – 48.3 by 4.4 by 18.8 cm (19.0 by 1.7 by 7.4 in.)

SC-2075 – Connector block with breadboard area for prototyping, as well as BNC and spring terminal connectivity for 68-pin M Series, E Series, and B Series multifunction DAQ devices. The built-in ± 15 V or adjustable 0 to 5 V power supply and LEDs for digital lines make the SC-2075, ideal for academic laboratories.

SC-2075778147-90

Dimensions – 26.7 by 20.7 by 4.4 cm (10.5 by 8.2 by 1.7 in.)

TBX-68 – Connector block for easy connection of field I/O signals to 68-pin M Series, E Series, S Series, and B Series DAQ devices. The TBX-68 includes 68 screw terminals and one 68-pin male connector for direct connection to 68-pin cables. The TBX-68 is mounted in a protective plastic base with hardware for mounting on a standard DIN rail.

TBX-68777141-01

Dimensions – 12.50 by 10.74 cm (4.92 by 4.23 in.)



68M-50F

RTSI Bus Cable

SCC Portable, Modular
Signal Conditioning

SCXI High-Performance
Signal Conditioning

BNC-2100 Series

BNC-2090

SC-2075

Multifunction DAQ Accessories and Cables

CA-1000 – A configurable enclosure that gives you maximum user-defined connectivity and flexibility through customized panelettes. Each enclosure can accommodate up to nine panelettes.

CA-1000See page 222

Dimensions – 30.7 by 25.4 by 4.3 cm (21.1 by 10 by 1.7 in.)

TB-2705 – Terminal block for 68-pin devices. It latches to the front of your PXI E Series or S Series DAQ module with locking screws and provides strain relief and easy access to your I/O signals through screw terminals.

TB-2705778241-01

Dimensions – 8.43 by 10.41 by 2.03 cm (3.32 by 4.1 by 0.8 in.)

SCB-68 and SCB-100 – Shielded I/O connector blocks for rugged, low-noise signal termination with M Series, E Series, S Series, or B Series DAQ devices. They include general-purpose breadboard areas and an IC temperature sensor for cold-junction compensation in temperature measurements.

SCB-68 (for M Series, 68-pin E Series,

S Series, or B Series)776844-01

Dimensions – 19.5 by 15.2 by 4.5 cm (7.7 by 6.0 by 1.8 in.)

SCB-100 (for 100-pin E Series).....776990-01

Dimensions – 19.5 by 15.2 by 4.5 cm (7.7 by 6.0 by 1.8 in.)

CB-68LP and CB-68LPR – Low-cost termination accessories with 68 screw terminals for easy connection of I/O signals to 68-pin M Series, E Series, S Series, or B Series multifunction DAQ devices. They include one 68-pin male connector for direct connection to 68-pin cables and standoffs for use on a desktop or for mounting in a custom panel. The CB-68LP has a vertical-mounted 68-pin connector. The CB-68LPR has a right-angle mounted connector, and can be used with the CA-1000 (see page 222).

CB-68LP777145-01

Dimensions – 14.35 by 10.74 cm (5.65 by 4.23 in.)

CB-68LPR777145-02

Dimensions – 7.62 by 16.19 cm (3.00 by 6.36 in.)

DAQ Signal Accessory – For demonstration of analog, digital, and counter/timer functions of DAQ devices. You can use the DAQ Signal Accessory with any 68-pin M Series, E Series, or B Series DAQ device. It features a built-in function generator, quadrature encoder, solid-state relay, IC temperature sensor, noise generator, microphone jack, thermocouple jack, four LEDs, and a digital trigger button.

DAQ Signal Accessory777382-01

Dimensions – 12.7 by 12.7 cm (5.0 by 5.0 in.)

Custom Connectivity Components

68-Pin Custom Cable Connector/Backshell Kit – A 68-pin kit used to make custom cables. Solder-cup contacts are available for soldering cable wires to the connector.

68-pin connector/backshell kit776832-01

PCB Mounting Connectors for Custom Accessories – Build custom accessories that connect to 68-conductor or 100-conductor shielded and ribbon cables using these connectors. Two connectors are available, one for right-angle and one for vertical mounting onto a PCB.

68-pin, male, right-angle mounting777600-01

68-pin, male, vertical mounting777601-01

100-pin, female, right-angle mounting.....777778-01

100-pin, female, vertical mounting.....777779-01

Strain-Relief Accessory – Attaches to the bottom of your notebook computer or DAQPad and provides adjustable strain relief for one or two PCMCIA cables attached to DAQCards, or a USB cable attached to a DAQPad device.

Strain-relief accessory777550-01



CA-1000



TB-2705

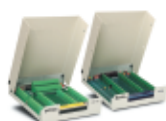

SCB-68 and SCB-100



CB-68LP and CB-68LPR



DAQ Signal Accessory



Strain-Relief Accessory