

REVISIONS				
P	LTR	DESCRIPTION	DATE	APVD
F		LOGO CHANGE	07APR2013	PP KZ

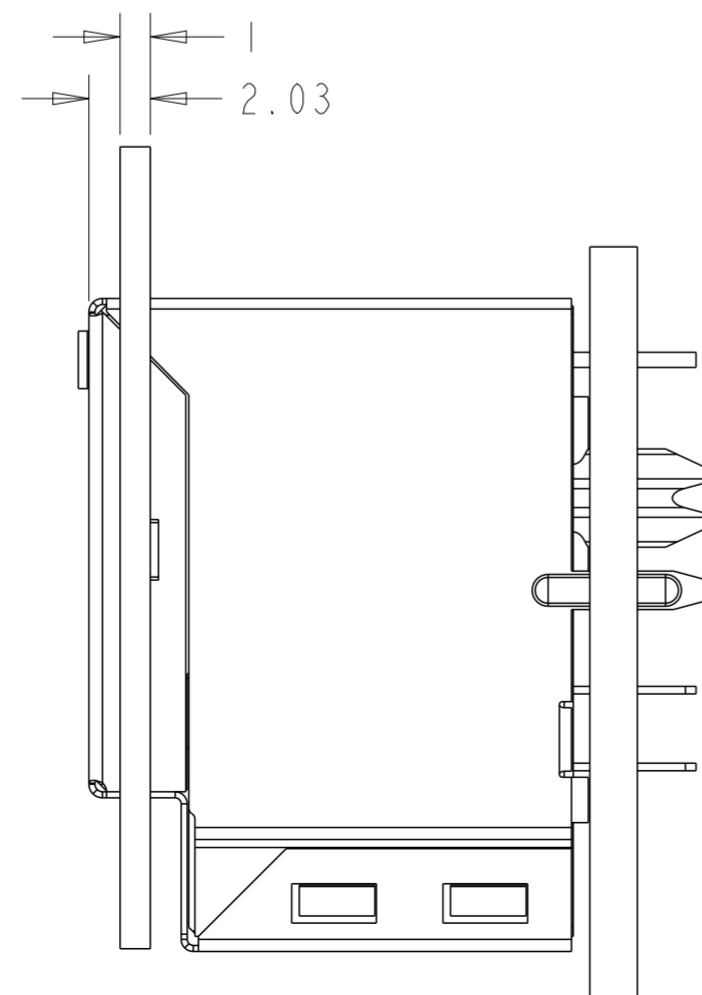

1. MATERIALS

HOUSING: THERMOPLASTIC, BLACK, FLAMMABILITY RATED UL 94V-0
 SHIELD: BRASS, 0.20mm THICK, PREPLATED WITH MIN 0.76um SEMI-BRIGHT NICKEL POST DIPPED WITH 2.54um MIN SAC SOLDER AT GROUND PINS.
 CONTACTS: PHOSPHOR BRONZE, PLATED WITH 1.27um MIN OVERALL NICKEL UNDERPLATE, SELECTIVE 1.27um MIN GOLD AT MATING INTERFACE AND 2.54um MIN MATTE TIN ON SOLDER TAILS. OR 1.27um MIN NICKEL UNDERPLATE, WITH 0.05um GOLD PLATING OVER 0.76um MIN PALLADIUM NICKEL PLATING AT MATING INTERFACE AND 2.54um MIN MATTE TIN ON SOLDER TAILS.
 SOLDER TAIL: PHOSPHOR BRONZE, WITH 1.27um MIN OVERALL NICKEL UNDERPLATE AND PLATED WITH 2.54um MIN TIN
 LED: DIFFUSED EPOXY LENS, 0.50mm SQUARE CARBON STEEL WIREFRAME LEADS PREPLATED WITH 2.03um MIN SILVER OVER 1.02um MIN NICKEL OVER 1.02um MIN COPPER UNDERPLATE POST PLATED WITH 2.54um MIN TIN

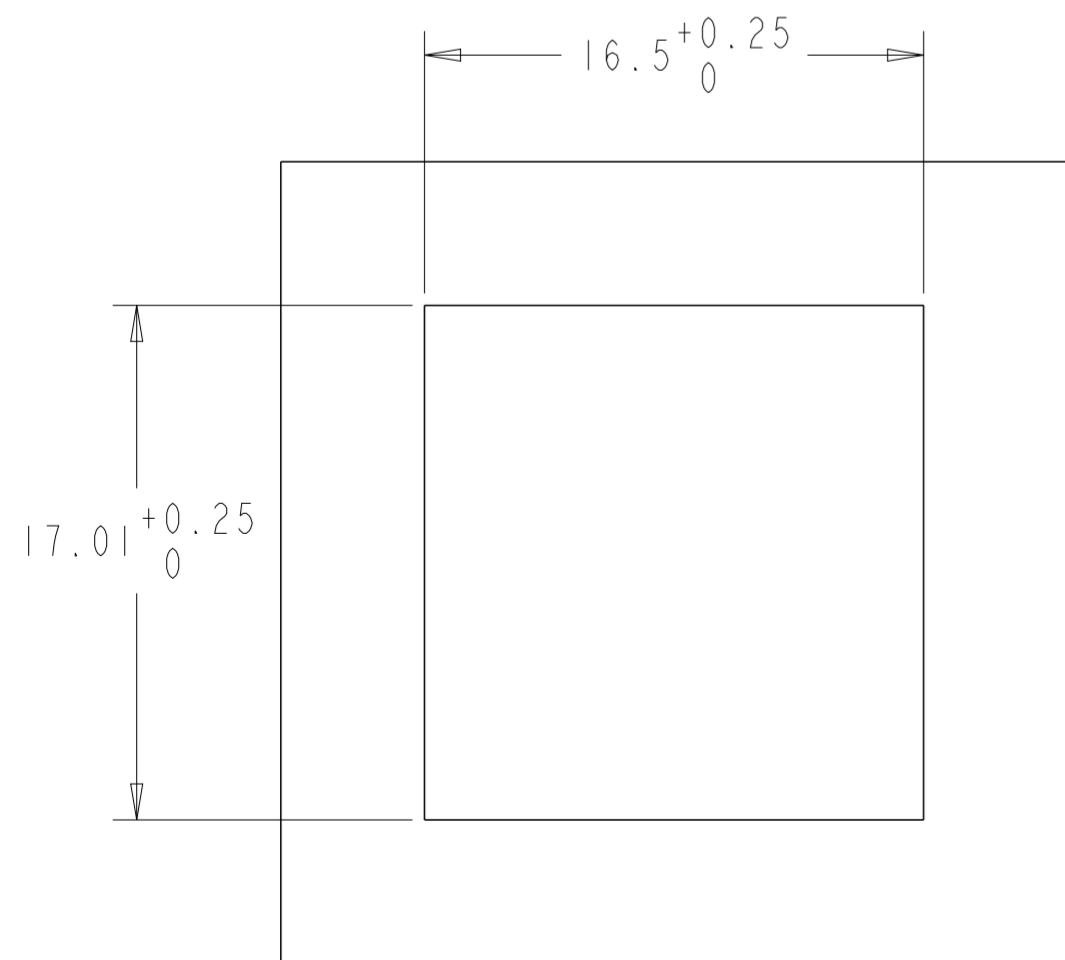
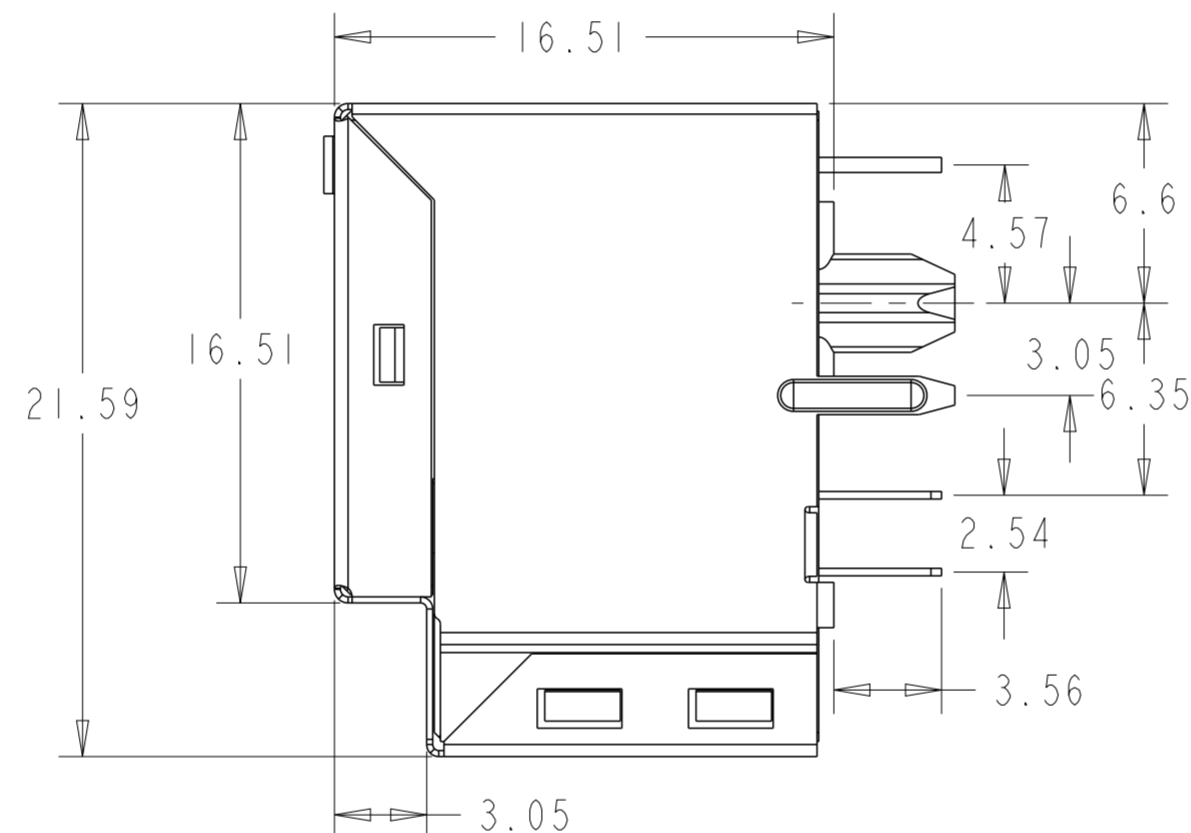
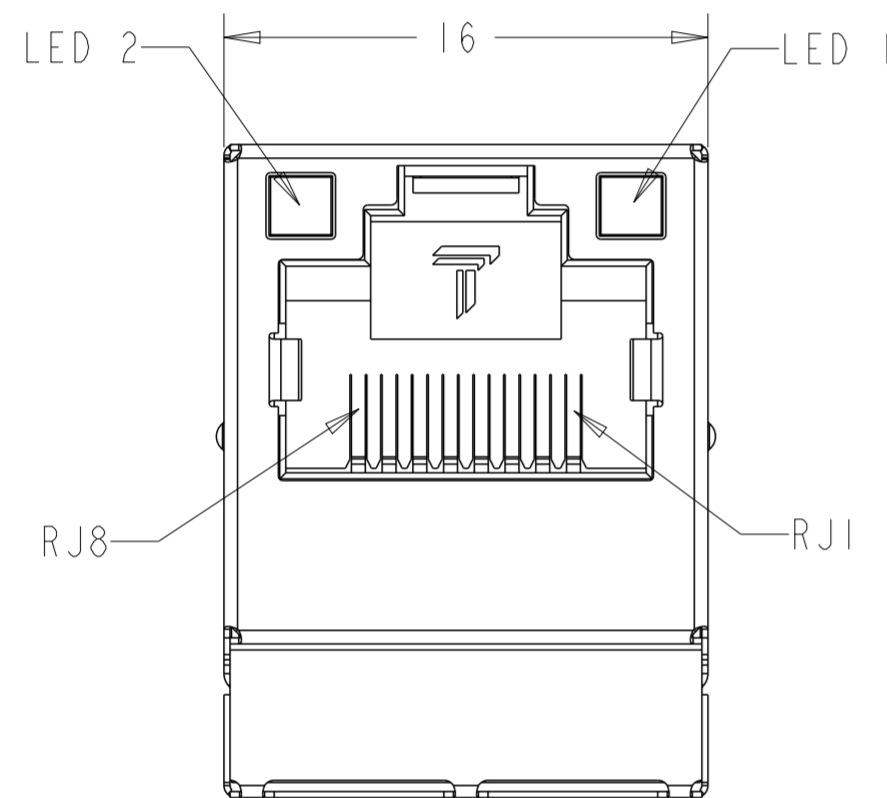
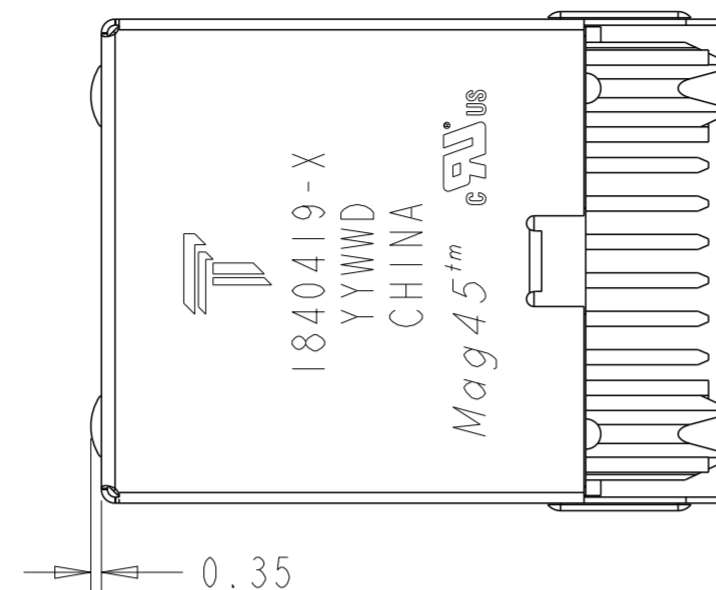
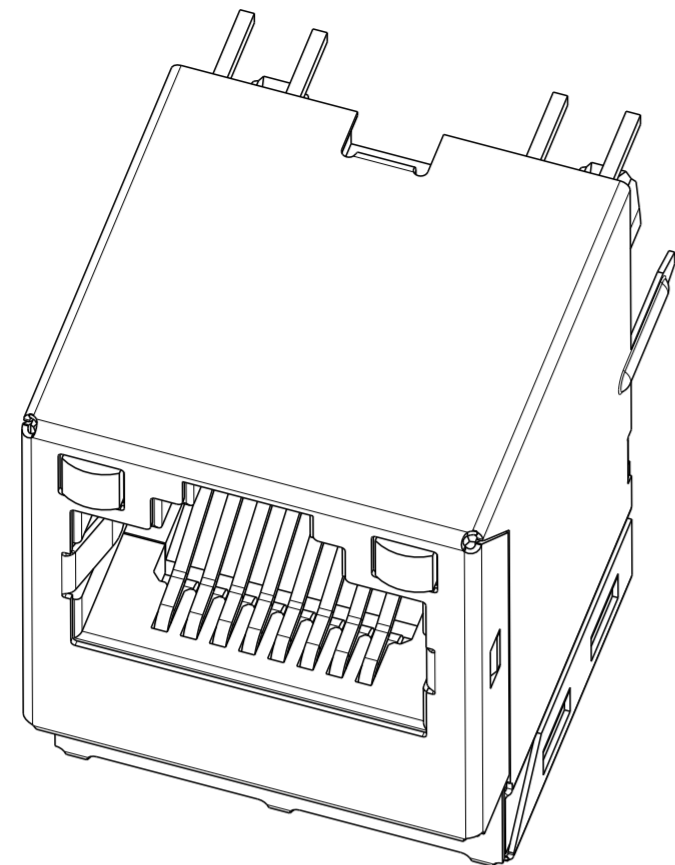

MAGNETICS

-APPLICATION: 10/100 BASE-T
 -IMPEDANCE: 100 OHMS
 -TURNS RATIO (CHIP:CABLE): TX = 1:1, RX = 1:1
 -OPEN CIRCUIT INDUCTANCE (OCL): 350uH MIN @100kHz, 0.1VRMS, 8mADC BIAS FROM 0°C TO 70°C, TX AND RX
 -PERFORMANCE @ 25°C:
 INSERTION LOSS (IL): 1.1dB MAX FROM 0.5MHz TO 100MHz
 RETURN LOSS (RL): 18dB MIN FROM 0.5MHz TO 30MHz
 18-20LOG(f/30)dB MIN FROM 30.1MHz TO 60MHz
 12dB MIN FROM 60.1MHz TO 80MHz
 CROSSTALK ATTENUATION: 35dB MIN FROM 0.5MHz TO 40MHz
 33-20LOG(f/50)dB MIN FROM 40.1MHz TO 100MHz
 COMMON MODE REJECTION RATIO (CMRR): 30dB MIN FROM 0.5MHz TO 100MHz
 -ISOLATION VOLTAGE: COMPLIES WITH IEEE802.3 2002, PARA 23.5.1.1, ITEM b.



THE MAGNETIC ARE SYMMETRICAL AND SUPPORT AUTO-MDIX OPERATION.

4. OPERATING TEMPERATURE: 0 - 70°C

5. LED IS DRIVEN WITH CONSTANT CURRENT AT APPROX 20mA.

DOMINANT WAVELENGTH(λ D)
 GREEN 568nm TYP.at IF=20mA
 YELLOW 588nm TYP.at IF=20mA

FORWARD VOLTAGE(VF):
 GREEN 2.2V TYP.at IF=20mA
 YELLOW 2.1V TYP.at IF=20mA

6. ALL DIMENSIONS TO BE NOMINAL UNLESS OTHERWISE NOTED

7. RJ45 CAVITY CONFORMS TO FCC RULES AND REGULATION PART 68 SUBPART F.

YES	YELLOW	GREEN	1-1840419-3
NO	GRN/YEL	GRN/YEL	1840419-4
NO	YELLOW	GREEN	1840419-3
NO	GREEN	YELLOW	1840419-2
NO	GREEN	GREEN	1840419-1
CUT OUT	LED 1	LED 2	PART NUMBER

THIS DRAWING IS A CONTROLLED DOCUMENT.		DWN	18AUG2006		TRP connector	
		CHK	18AUG2006		Dongguan China	
		APVD	18AUG2006			
		PRODUCT SPEC	108-2100			
DIMENSIONS: mm		TOLERANCES UNLESS OTHERWISE SPECIFIED:		NAME		IX1 MAG45(TM) MODULAR JACK, VERTICAL, 426P13 CIRCUIT WITH LED
0 PLC ±0.25		1 PLC ±0.25		SIZE		A2
2 PLC ±0.25		3 PLC ±0.25		CAGE CODE		00779
4 PLC ±0.25		4 PLC ±		DRAWING NO		C-1840419
MATERIAL		FINISH		RESTRICTED TO		
				WEIGHT		
				CUSTOMER DRAWING		
				SCALE		1:1
				SHEET		1 OF 2
				REV		F

426P13 10/100 BASE-T CIRCUIT $\triangle \triangle$

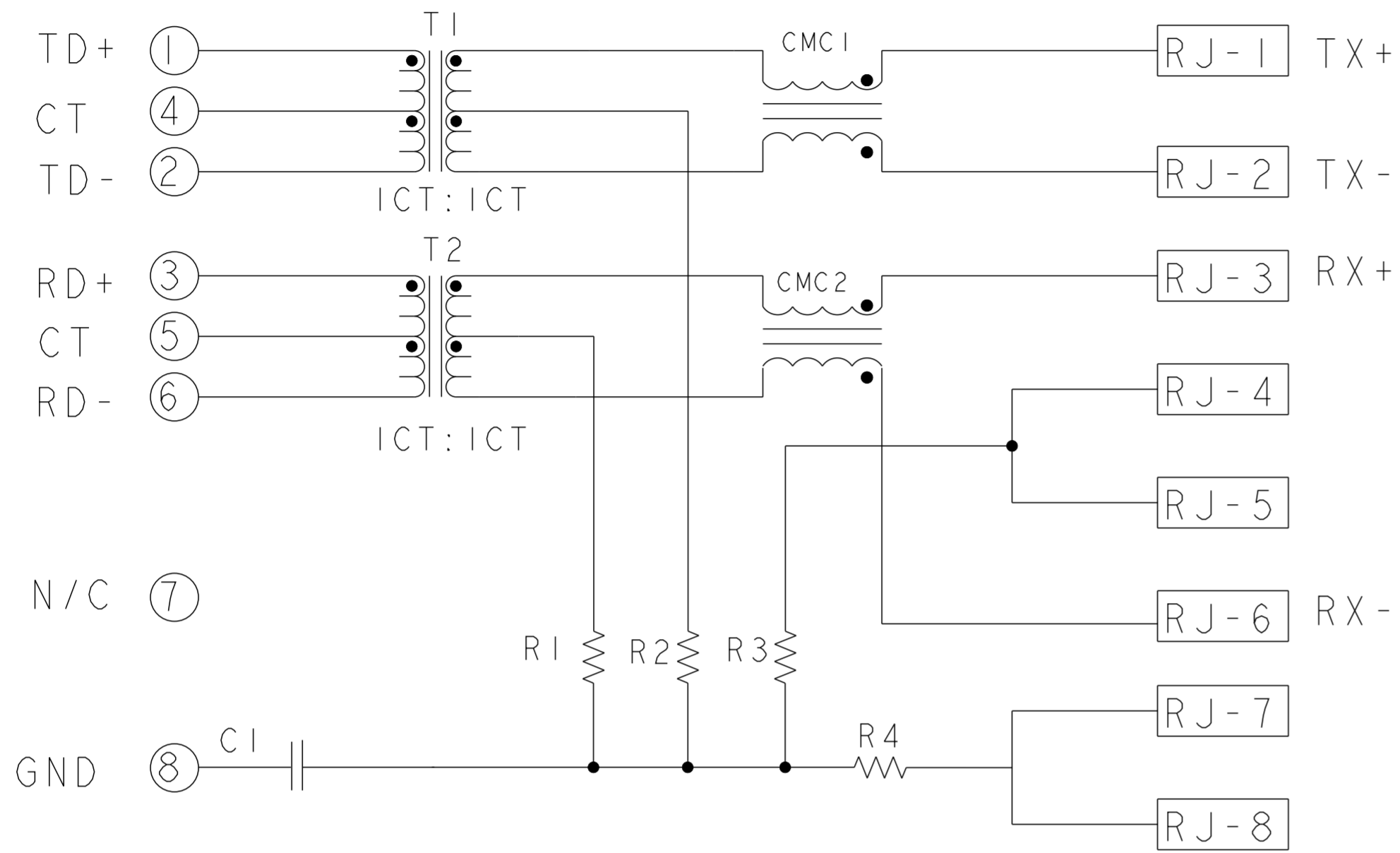

C1 = 1000pF, 2KV, CAPACITOR
R1 - R4 = 75 ohms, RESISTOR

CONNECTOR ENVELOPE

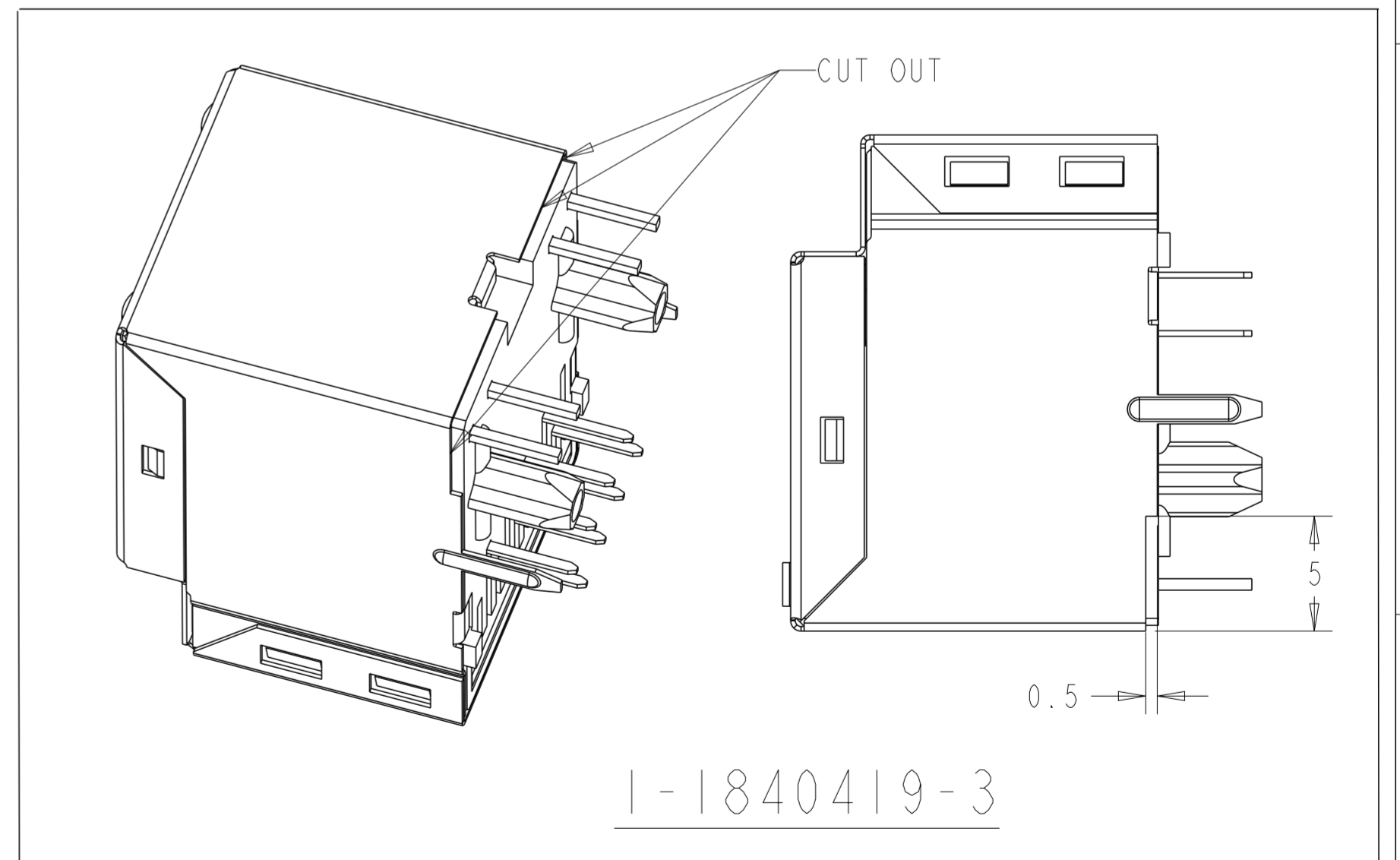
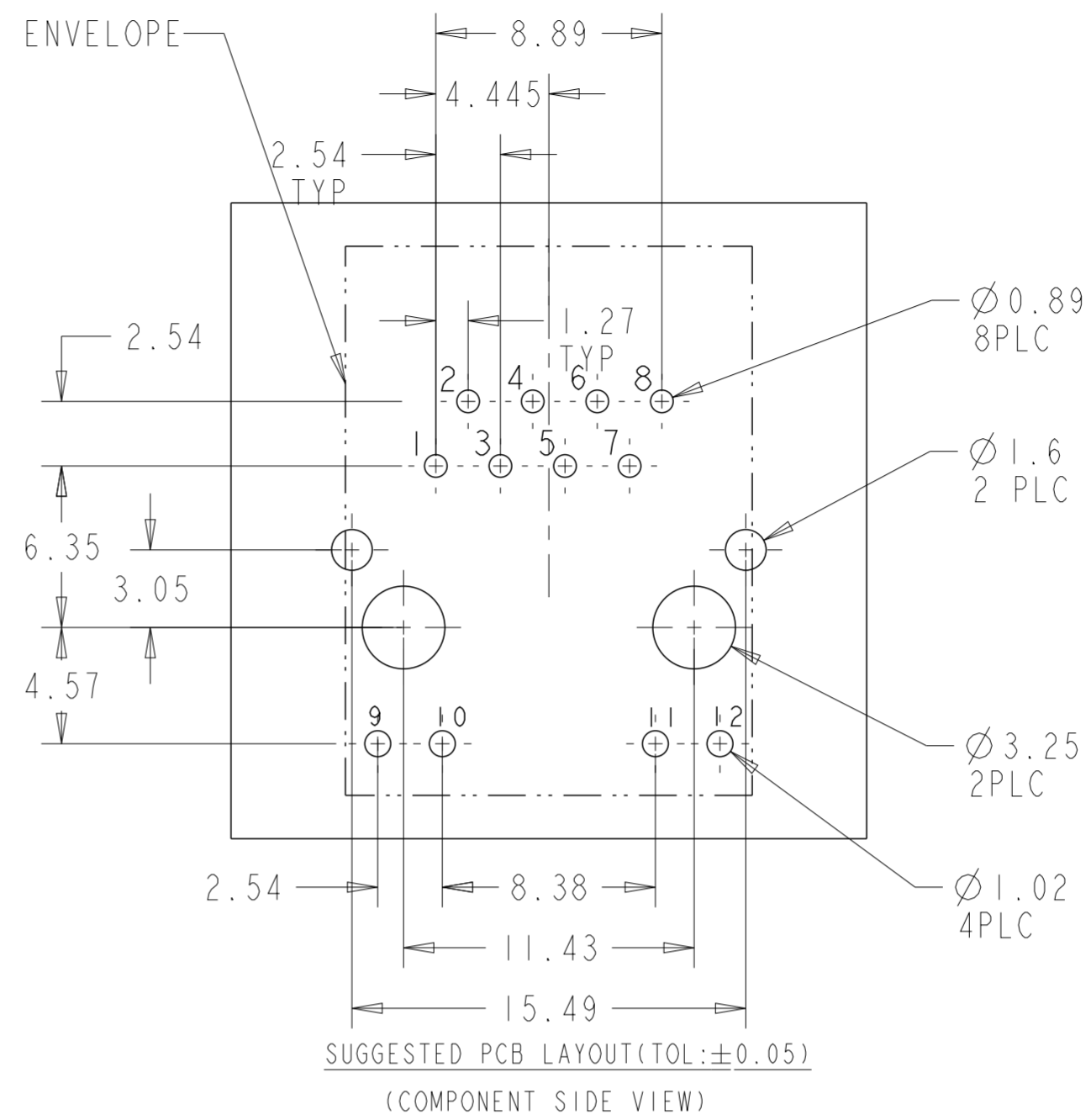

SINGLE COLOR LED

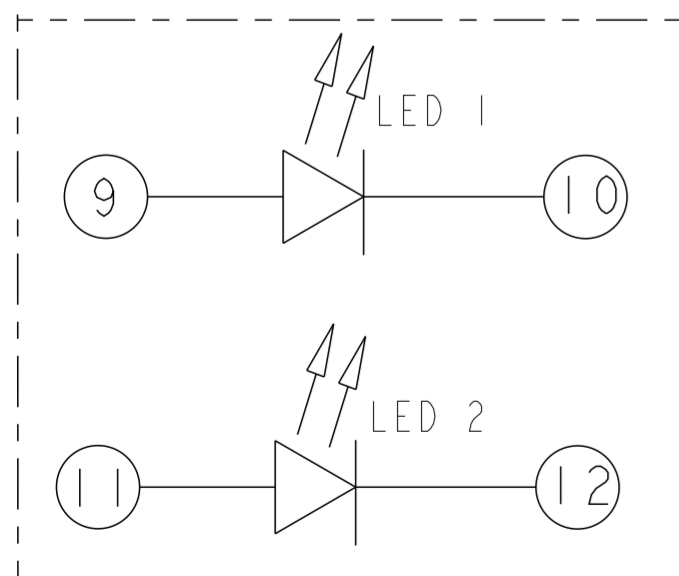

BI-COLOR LED

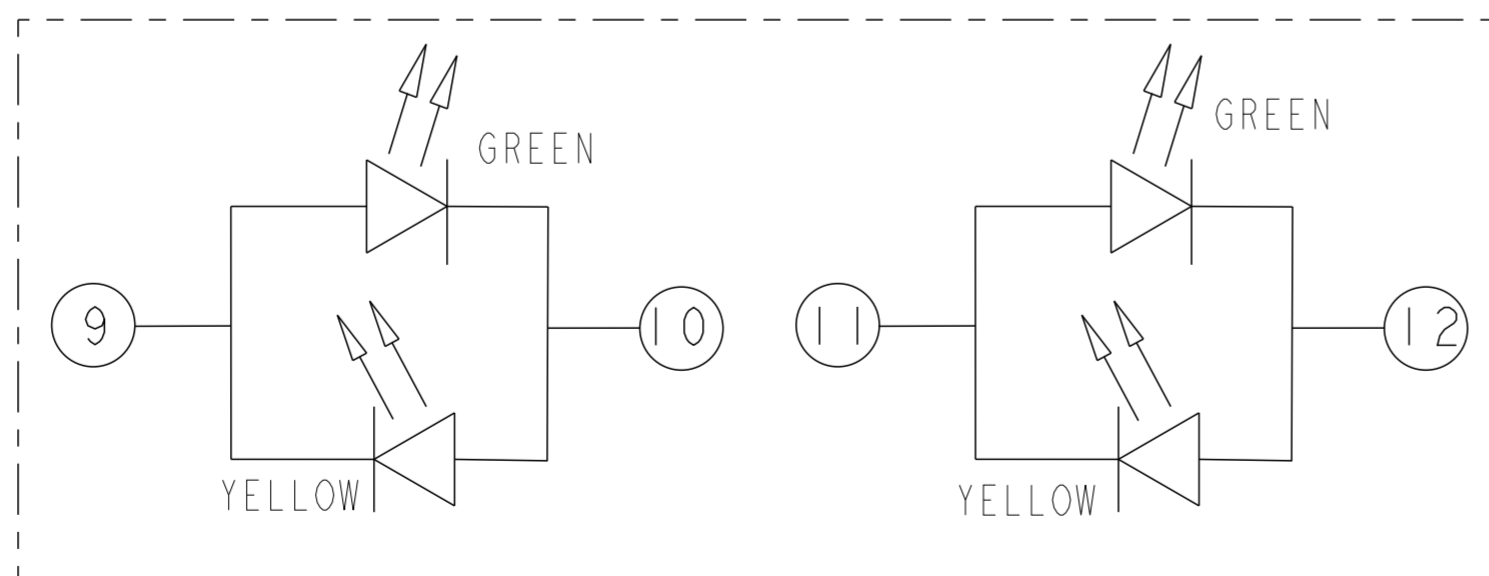

THIS DRAWING IS A CONTROLLED DOCUMENT.		DWN TOMMY REN 18AUG2006	 TRP connector Dongguan China	
		CHK KEITH ZHU 18AUG2006		
DIMENSIONS:		APVD TEDDY XIONG 18AUG2006	NAME IX1 MAG45(TM) MODULAR JACK, VERTICAL, 426P13 CIRCUIT WITH LED	
mm	TOLERANCES UNLESS OTHERWISE SPECIFIED:	PRODUCT SPEC 108-2100	SIZE A2	CAGE CODE 00779
	0 PLC ±0.25	APPLICATION SPEC -	DRAWING NO C-1840419	RESTRICTED TO -
	1 PLC ±0.25	WEIGHT -	SCALE 1:1	SHEET 2 OF 2
	2 PLC ±0.25	CUSTOMER DRAWING	REV F	
	3 PLC ±0.25			
	4 PLC ±			
	ANGLES ±			
	FINISH			