

IMC 1,5/10-G-3,5 RN P20 THR - PCB header



1830647

<https://www.phoenixcontact.com/pc/products/1830647>

Please be informed that the data shown in this PDF document is generated from our Online Catalog. Please find the complete data in the user documentation. Our General Terms of Use for Downloads are valid.



PCB headers, nominal cross section: 1.5 mm², color: black, nominal current: 8 A, rated voltage (III/2): 160 V, contact surface: Tin, type of contact: Socket, number of potentials: 10, number of rows: 1, number of positions: 10, number of connections: 10, product range: IMC 1,5/..-G-RN-THR, pitch: 3.5 mm, mounting: THR soldering, pin layout: Linear pinning, solder pin [P]: 2 mm, number of solder pins per potential: 2, plug-in system: COMBICON MC 1,5, Pin connector pattern alignment: Standard, locking: Snap-in locking, mounting: Engagement nose, type of packaging: packed in cardboard

Your advantages

- Designed for integration into the SMT soldering process
- Intuitive locking mechanism prevents accidental disconnection
- Inverted header with socket contacts for touch-proof device outputs or PCB/PCB connections

Commercial Data

Item number	1830647
Packing unit	50 pc
Minimum order quantity	50 pc
Note	Made to Order (non-returnable)
Product Key	AABTIA
Catalog Page	Page 17 (NTK-2014)
GTIN	4046356887601
Weight per Piece (including packing)	3.63 g
Weight per Piece (excluding packing)	3.63 g
Customs tariff number	85366930
Country of origin	DE

1830647

<https://www.phoenixcontact.com/pc/products/1830647>

Technical Data

Product properties

Type	Inverted
Product line	COMBICON Connectors S
Product type	PCB headers
Product family	IMC 1,5/...-G-RN-THR
Number of positions	10
Pitch	3.5 mm
Number of connections	10
Number of rows	1
Mounting flange	Engagement nose
Number of potentials	10
Pin layout	Linear pinning
Solder pins per potential	2

Electrical properties

Nominal current I_N	8 A
Nominal voltage U_N	160 V
Degree of pollution	3
Contact resistance	2.1 mΩ
Rated voltage (III/3)	160 V
Rated surge voltage (III/3)	2.5 kV
Rated voltage (III/2)	160 V
Rated surge voltage (III/2)	2.5 kV
Rated voltage (II/2)	320 V
Rated surge voltage (II/2)	2.5 kV

Mounting

Mounting type	THR soldering
Pin layout	Linear pinning

Processing notes

Process	Reflow/wave soldering
Moisture Sensitive Level	MSL 1
Classification temperature T_c	260 °C
Solder cycles in the reflow	3

Material specifications

Material data - contact

Note	WEEE/RoHS-compliant, free of whiskers according to IEC 60068-2-82/JEDEC JESD 201
Contact material	Cu alloy
Surface characteristics	hot-dip tin-plated

IMC 1,5/10-G-3,5 RN P20 THR - PCB header

1830647

<https://www.phoenixcontact.com/pc/products/1830647>

Metal surface contact area (top layer)	Tin (2 - 4 µm Sn)
Metal surface soldering area (top layer)	Tin (2 - 4 µm Sn)

Material data - housing

Color (Housing)	black (9005)
Insulating material	LCP
Insulating material group	IIIa
CTI according to IEC 60112	175
Flammability rating according to UL 94	V0

Dimensions

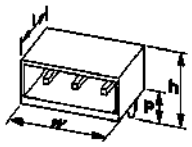
Dimensional drawing	
Pitch	3.5 mm
Width [w]	35.8 mm
Height [h]	8.3 mm
Length [l]	14.5 mm
Installed height	6.3 mm
Solder pin length [P]	2 mm
Pin dimensions	1.12 mm

PCB design

Pin spacing	2.54 mm
Hole diameter	1.2 mm

Mechanical tests

Visual inspection

Specification	IEC 60512-1-1:2002-02
Result	Test passed

Dimension check

Specification	IEC 60512-1-2:2002-02
Result	Test passed

Resistance of inscriptions

Specification	IEC 60068-2-70:1995-12
Result	Test passed

Polarization and coding

Specification	IEC 60512-13-5:2006-02
Result	Test passed

Contact holder in insert

IMC 1,5/10-G-3,5 RN P20 THR - PCB header



1830647

<https://www.phoenixcontact.com/pc/products/1830647>

Specification	IEC 60512-15-1:2008-05
Contact holder in insert Requirements >20 N	Test passed

Insertion and withdrawal forces

Result	Test passed
No. of cycles	25
Insertion strength per pos. approx.	3 N
Withdraw strength per pos. approx.	3 N

Electrical tests

Thermal test | Test group C

Specification	IEC 60512-5-1:2002-02
Tested number of positions	12

Insulation resistance

Specification	IEC 60512-3-1:2002-02
Insulation resistance, neighboring positions	> 5 MΩ

Temperature cycles

Specification	IEC 60999-1:1999-11
Result	Test passed

Air clearances and creepage distances |

Specification	IEC 60664-1:2007-04
Insulating material group	IIIa
Comparative tracking index (IEC 60112)	CTI 175
Rated insulation voltage (III/3)	160 V
Rated surge voltage (III/3)	2.5 kV
minimum clearance value - non-homogenous field (III/3)	1.5 mm
minimum creepage distance (III/3)	2.5 mm
Rated insulation voltage (III/2)	160 V
Rated surge voltage (III/2)	2.5 kV
minimum clearance value - non-homogenous field (III/2)	1.5 mm
minimum creepage distance (III/2)	1.6 mm
Rated insulation voltage (II/2)	320 V
Rated surge voltage (II/2)	2.5 kV
minimum clearance value - non-homogenous field (II/2)	1.5 mm
minimum creepage distance (II/2)	3.2 mm

Environmental and real-life conditions

Vibration test

Specification	IEC 60068-2-6:2007-12
Frequency	10 - 150 - 10 Hz
Sweep speed	1 octave/min

IMC 1,5/10-G-3,5 RN P20 THR - PCB header



1830647

<https://www.phoenixcontact.com/pc/products/1830647>

Amplitude	0.35 mm (10 Hz ... 60.1 Hz)
Sweep speed	5g (60.1 Hz ... 150 Hz)
Test duration per axis	2.5 h

Durability test

Specification	IEC 60512-9-1:2010-03
Impulse withstand voltage at sea level	2.95 kV
Contact resistance R ₁	2.1 mΩ
Contact resistance R ₂	2.3 mΩ
Insertion/withdrawal cycles	25
Insulation resistance, neighboring positions	> 5 MΩ

Climatic test

Specification	ISO 6988:1985-02
Corrosive stress	0.2 dm ³ SO ₂ on 300 dm ³ /40 °C/1 cycle
Thermal stress	100 °C/168 h
Power-frequency withstand voltage	1.39 kV

Ambient conditions

Ambient temperature (operation)	-40 °C ... 100 °C (dependent on the derating curve)
Ambient temperature (storage/transport)	-40 °C ... 70 °C
Relative humidity (storage/transport)	30 % ... 70 %
Ambient temperature (assembly)	-5 °C ... 100 °C

Drawings

Diagram

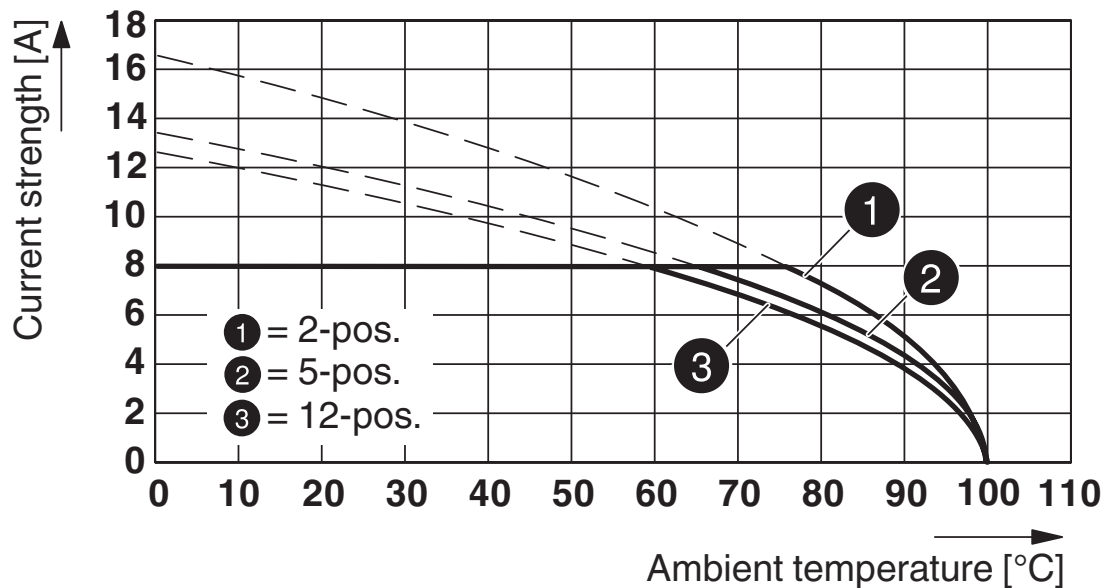

Type: IFMC 1,5/...-ST-3,5-RF with IMC 1,5/...-G-3,5 RN P20 THR

Dimensional drawing

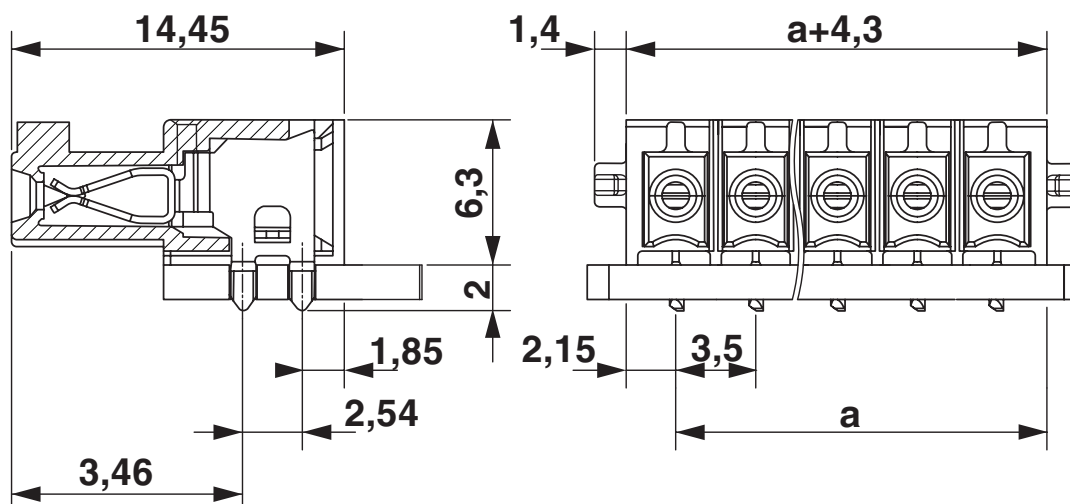

IMC 1,5/10-G-3,5 RN P20 THR - PCB header



1830647

<https://www.phoenixcontact.com/pc/products/1830647>

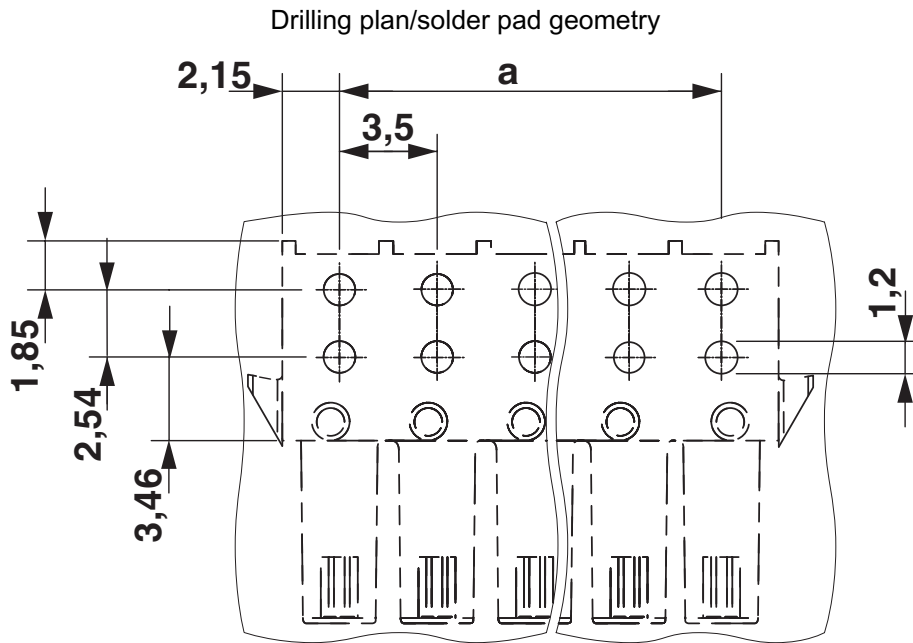

IMC 1,5/10-G-3,5 RN P20 THR - PCB header





1830647

<https://www.phoenixcontact.com/pc/products/1830647>

Approvals

To download certificates, visit the product detail page: <https://www.phoenixcontact.com/pc/products/1830647>

 IECEE CB Scheme Approval ID: DE1-60987-B1B2				
	Nominal Voltage U_N	Nominal Current I_N	Cross Section AWG	Cross Section mm^2
	160 V	8 A	-	-

 EAC Approval ID: B.01687				
--	--	--	--	--

 cULus Recognized Approval ID: E60425-20110128				
	Nominal Voltage U_N	Nominal Current I_N	Cross Section AWG	Cross Section mm^2
Use group B	300 V	8 A	-	-
Use group D	300 V	8 A	-	-

 VDE Zeichengenehmigung Approval ID: 40011723				
	Nominal Voltage U_N	Nominal Current I_N	Cross Section AWG	Cross Section mm^2
	160 V	8 A	-	-

IMC 1,5/10-G-3,5 RN P20 THR - PCB header



1830647

<https://www.phoenixcontact.com/pc/products/1830647>

Classifications

ECLASS

ECLASS-11.0	27460201
ECLASS-12.0	27460201
ECLASS-13.0	27460201

ETIM

ETIM 8.0	EC002637
----------	----------

UNSPSC

UNSPSC 21.0	39121400
-------------	----------

IMC 1,5/10-G-3,5 RN P20 THR - PCB header



1830647

<https://www.phoenixcontact.com/pc/products/1830647>

Environmental Product Compliance

China RoHS	Environmentally friendly use period: unlimited = EFUP-e
	No hazardous substances above threshold values

Phoenix Contact 2023 © - all rights reserved
<https://www.phoenixcontact.com>

PHOENIX CONTACT GmbH & Co. KG
Flachmarktstraße 8
D-32825 Blomberg
+49 (0) 5235-3 00
info@phoenixcontact.com