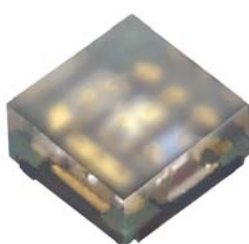

## SMD ■

## 18-038/RSGHBHC1-S03/2T

**Features**

- Package in 8mm tape on 7" diameter reel
- Compatible with automatic placement equipment
- Compatible with infrared and vapor phase reflow
- Solder process
- Full-color type
- Pb-free
- Component solderable surface finish is Gold
- Component weight is 1.0 mg
- The Product itself will remain within RoHS compliant version
- Compliance with EU REACH
- Compliance Halogen Free.(Br<900ppm,Cl<900ppm,Br+Cl<1500ppm)

**Description**

- The 18-038 SMD LED is much smaller than lead frame type components, thus enable smaller board size, higher packing density, reduced storage space and finally smaller equipment to be obtained.
- Moreover, with its black PCB, the 18-038 possess an ideal solution for high-contrast and high-resolution indoor signage display.

**Applications**

- Indoor signage display applications
- Indoor decorating and entertainment design
- Flat backlight for LCD, switch and symbol
- Indicator and backlighting for all consumer electronics

## Device Selection Guide

Chip Materials	Emitted Color	Resin Color
AlGaInP	Brilliant Red	Water Clear
InGaN	Brilliant Green	
InGaN	Brilliant Blue	

## Absolute Maximum Ratings (Ta=25°C)

Parameter	Symbol	Rating	Unit
Forward Current	$I_F$	RS:25 GH:20 BH:20	mA
Peak Forward Current (Duty 1/10 @1KHz)	$I_{FP}$	RS:60 GH:50 BH:50	mA
Power Dissipation	$P_d$	RS:60 GH:70 BH:70	mW
Junction Temperature	$T_j$	100	°C
Operating Temperature	$T_{opr}$	-40 ~ +85	°C
Storage Temperature	$T_{stg}$	-40 ~ +90	°C
ESD (Classification acc. AEC Q101)	$ESD_{HBM}$	R:2000 G:150 B:150	V
Soldering Temperature	$T_{sol}$	Reflow Soldering : 260 °C for 10 sec. Hand Soldering : 350 °C for 3 sec.	

### Electro-Optical Characteristics (Ta=25°C)

Parameter	Symbol		Min.	Typ.	Max.	Unit	Condition
Luminous Intensity	Iv	RS	75.0	-----	226.0	mcd	I <sub>F</sub> =20mA
		GH	160.0	-----	447.0		
		BH	40.0	-----	144.0		
Viewing Angle	2θ <sub>1/2</sub>		-----	120	-----	deg	I <sub>F</sub> =20mA
Peak Wavelength	λ <sub>p</sub>	RS		632		nm	I <sub>F</sub> =20mA
		GH	-----	518	-----		
		BH		468			
Dominant Wavelength	λ <sub>d</sub>	RS	619.0		631.0	nm	I <sub>F</sub> =20mA
		GH	516.0	-----	531.0		
		BH	462.0		475.0		
Spectrum Radiation Bandwidth	Δλ	RS		20		nm	I <sub>F</sub> =20mA
		GH	-----	25	-----		
		BH		25			
Forward Voltage	V <sub>F</sub>	RS	1.7	2.0	2.35	V	I <sub>F</sub> =20mA
		GH	2.5	3.3	3.7		
		BH	2.5	3.3	3.7		
Reverse Current <sup>4</sup>	I <sub>R</sub>		-----	-----	10	μA	V <sub>R</sub> =5V

Note:

1. Tolerance of Luminous Intensity: ±10%
2. Tolerance of Dominant Wavelength: ±1nm
3. Tolerance of Forward Voltage: ±0.1V
4. Only for Electronic test

## Floating Bin(RS) Bin Range of Luminous Intensity

Bin Code	Min.	Max.	Unit	Condition
RA	75	90	mcd	$I_F = 20\text{mA}$
RB	90	108		
RC	108	130		
RD	130	156		
RE	156	188		
RF	188	226		

## Bin Range of Dominant Wavelength

Bin Code	Min.	Max.	Unit	Condition
R1	619.0	622.0	nm	$I_F = 20\text{mA}$
R2	622.0	625.0		
R3	625.0	628.0		
R4	628.0	631.0		

## Bin Range of Dominant Voltage

Bin Code	Min.	Max.	Unit	Condition
R1	1.7	2.35	v	$I_F = 20\text{mA}$

### Note:

1. Tolerance of Luminous Intensity:  $\pm 10\%$
2. Tolerance of Dominant Wavelength:  $\pm 1\text{nm}$
3. Tolerance of Forward Voltage:  $\pm 0.1\text{V}$

## Floating Bin(GH) Bin Range of Luminous Intensity

Bin Code	Min.	Max.	Unit	Condition
GA	160	192	mcd	$I_F = 20\text{mA}$
GB	192	230		
GC	230	276		
GD	276	332		
GE	332	398		
GF	398	477		

## Bin Range of Dominant Wavelength

Bin Code	Min.	Max.	Unit	Condition
G0	516.0	519.0	nm	$I_F = 20\text{mA}$
G1	519.0	522.0		
G2	522.0	525.0		
G3	525.0	528.0		
G4	528.0	531.0		

## Bin Range of Dominant Voltage

Bin Code	Min.	Max.	Unit	Condition
G1	2.5	3.7	v	$I_F = 20\text{mA}$

### Note:

1. Tolerance of Luminous Intensity:  $\pm 10\%$
2. Tolerance of Dominant Wavelength:  $\pm 1\text{nm}$
3. Tolerance of Forward Voltage:  $\pm 0.1\text{V}$

## Floating Bin(BH) Bin Range of Luminous Intensity

Bin Code	Min.	Max.	Unit	Condition
BA	40	58	mcd	$I_F = 20\text{mA}$
BB	58	70		
BC	70	84		
BD	84	100		
BE	100	120		
BF	120	144		

## Bin Range of Dominant Wavelength

Bin Code	Min.	Max.	Unit	Condition
B1	462.0	465.0	nm	$I_F = 20\text{mA}$
B2	465.0	468.0		
B3	468.0	471.0		
B4	471.0	474.0		
B5	474.0	475.0		

## Bin Range of Dominant Voltage

Bin Code	Min.	Max.	Unit	Condition
B1	2.5	3.7	v	$I_F = 20\text{mA}$

### Note:

1. Tolerance of Luminous Intensity:  $\pm 10\%$
2. Tolerance of Dominant Wavelength:  $\pm 1\text{nm}$
3. Tolerance of Forward Voltage:  $\pm 0.1\text{V}$

## Typical Electro-Optical Characteristics Curves

Spectrum Distribution

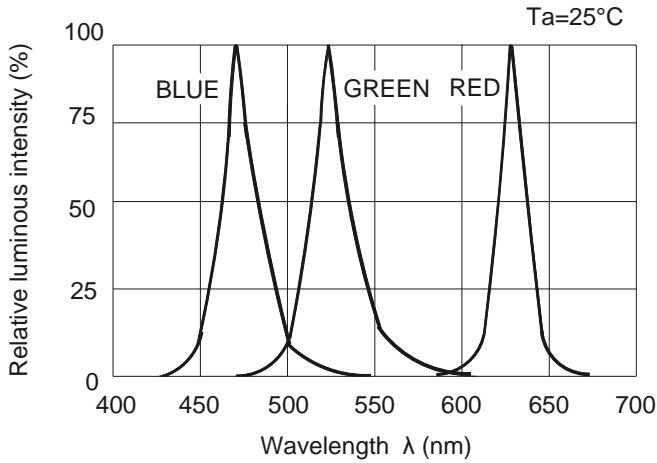

Radiation Diagram  $T_a=25^\circ\text{C}$

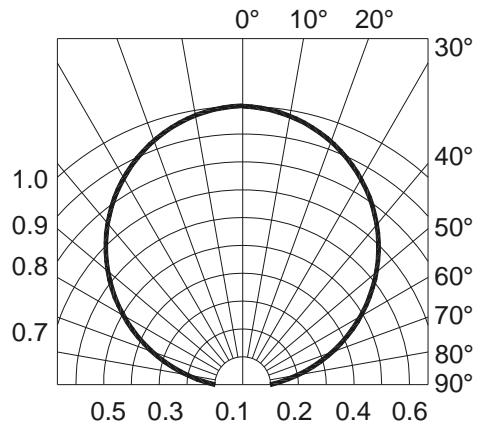

Forward Current vs. Forward Voltage

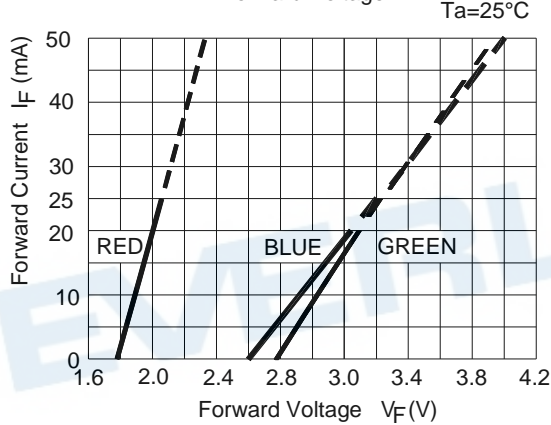

Forward Current Derating Curve

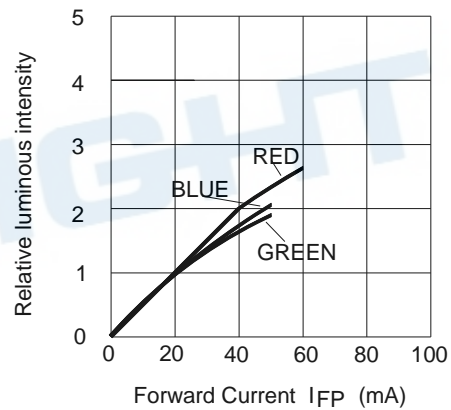

Ambient Temperature vs. Power Dissipation

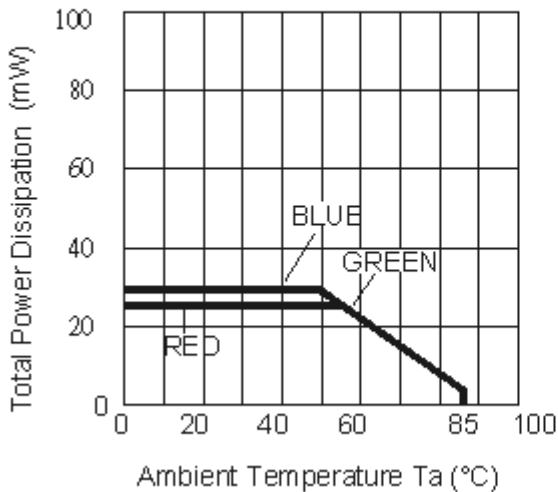

Ambient Temperature vs. Total Power Dissipation

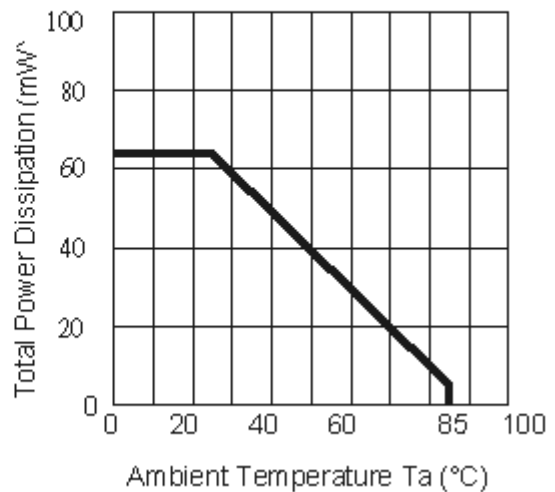

Package Dimension

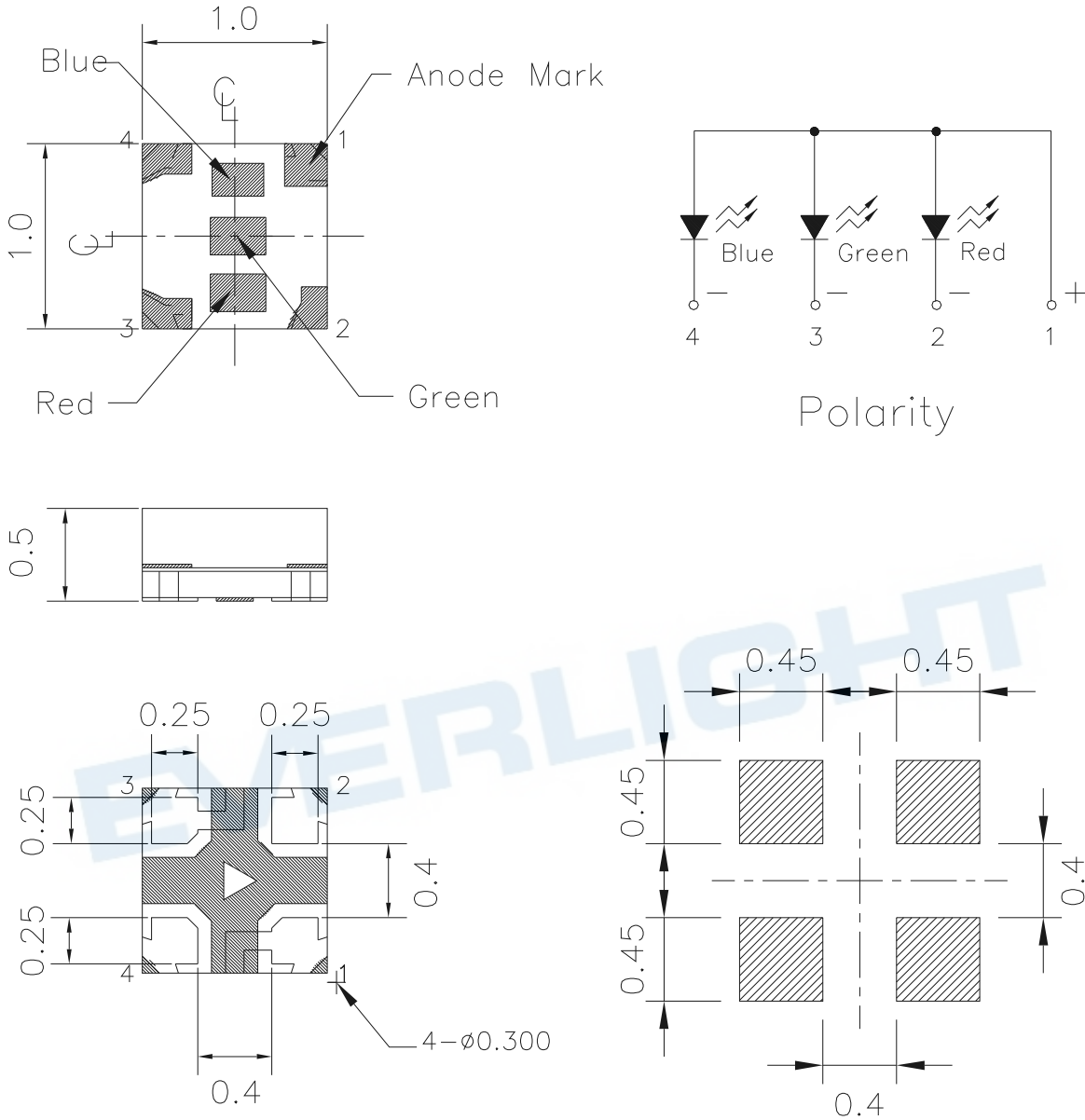

Note: Tolerances unless mentioned  $\pm 0.1\text{mm}$ . Unit = mm

## Moisture Resistant Packing Materials

### Label Explanation



- CPN: Customer's Product Number
- P/N: Product Number
- QTY: Packing Quantity
- CAT: Luminous Intensity Rank
- HUE: Dom. Wavelength Rank
- REF: Forward Voltage Rank
- LOT No: Lot Number

### Reel Dimensions

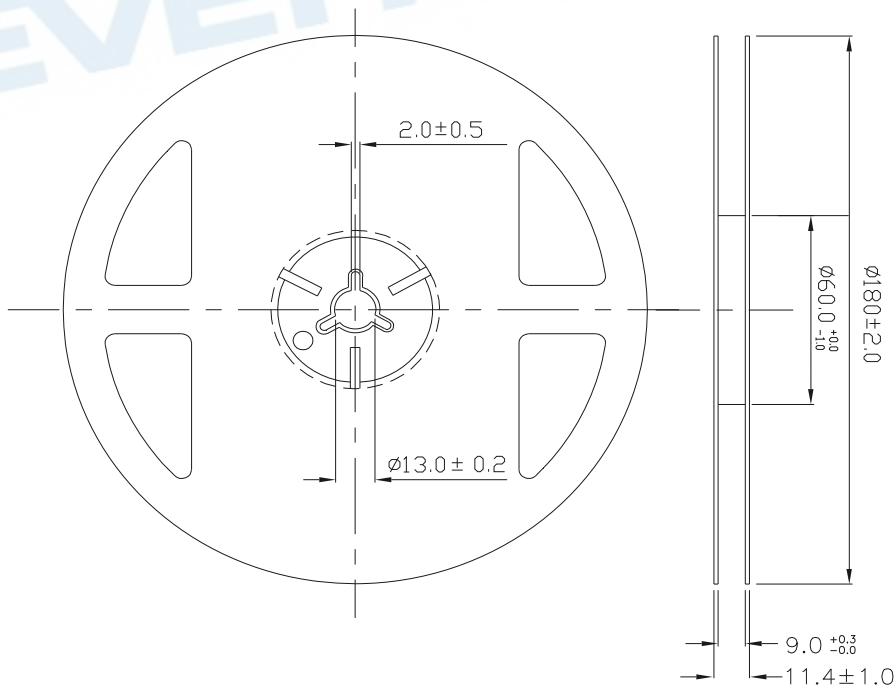

### Carrier Tape Dimensions:

Minimum packing amount is 2000 pcs per reel

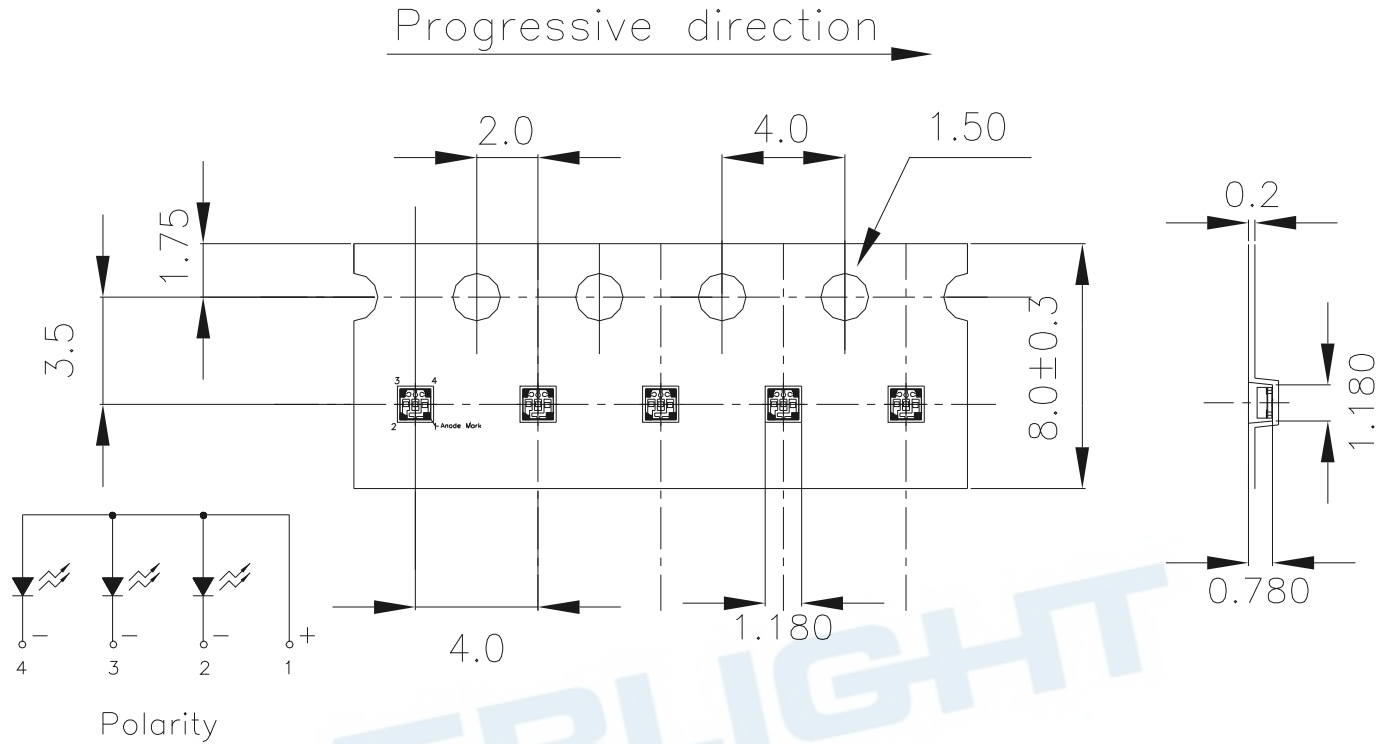

Note: Tolerances unless mentioned  $\pm 0.1$ mm. Unit = mm

### Moisture Resistant Packing Process

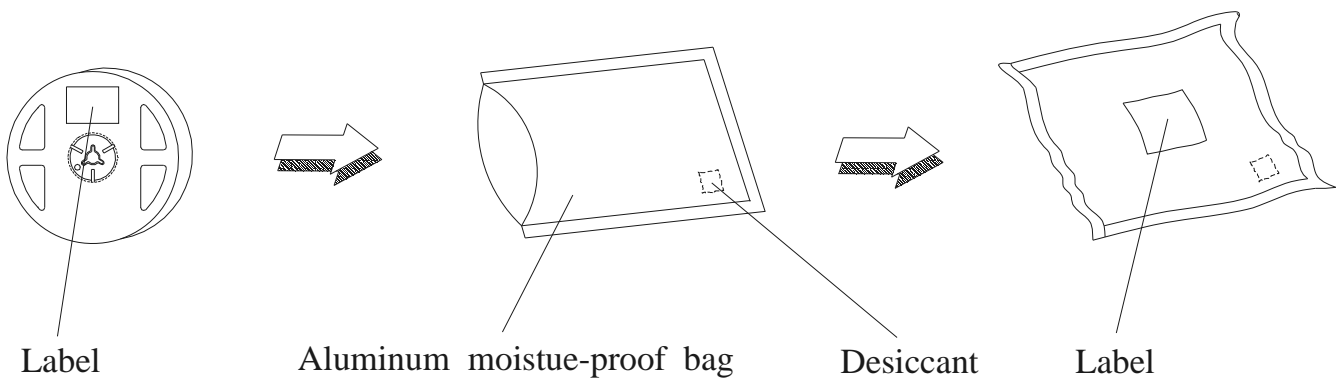

Note: Tolerances unless mentioned  $\pm 0.1$ mm. Unit = mm

## Precautions for Use

### 1. Over-current-proof

Customer must apply resistors for protection, otherwise slight voltage shift will cause big current change ( Burn out will happen ).

### 2. Storage

2.1 Do not open moisture proof bag before the products are ready to use.

2.2 Before opening the package: The LEDs should be kept at 30°C or less and 90%RH or less.

2.3 After opening the package: The LED's floor life is 168Hrs under 30°C or less and 60% RH or less. If unused LEDs remain, it should be stored in moisture proof packages.

2.4 If the moisture absorbent material (silica gel) has faded away or the LEDs have exceeded the storage time, baking treatment should be performed using the following conditions.

Baking treatment : 60±5°C for 24 hours.

### 3. Soldering Condition

#### 3.1 Pb-free solder temperature profile

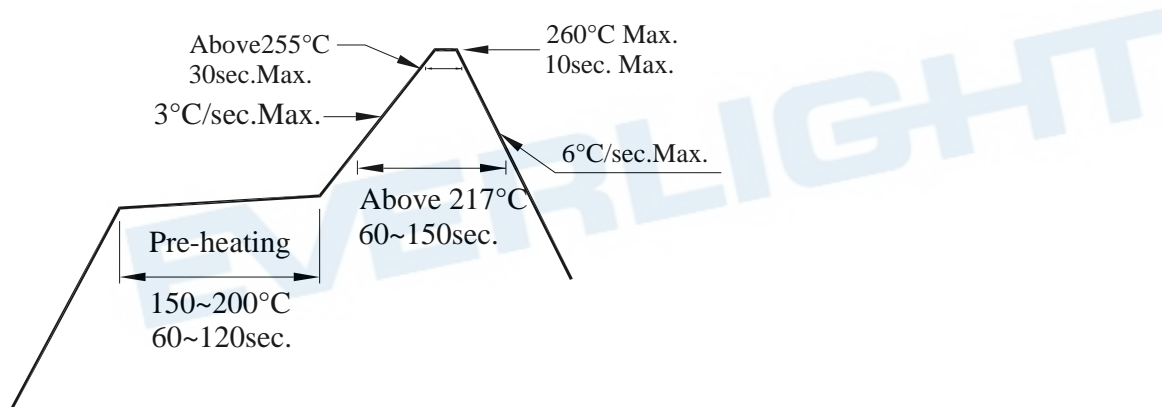

3.2 Reflow soldering should not be done more than two times.

3.3 When soldering, do not put stress on the LEDs during heating.

3.4 After soldering, do not warp the circuit board.

### 4. Soldering Iron

Each terminal is to go to the tip of soldering iron temperature less than 350°C for 3 seconds within once in less than the soldering iron capacity 25W. Leave two seconds and more intervals, and do soldering of each terminal. Be careful because the damage of the product is often started at the time of the hand solder.

## 5.Repairing

Repair should not be done after the LEDs have been soldered. When repairing is unavoidable, a double-head soldering iron should be used (as below figure). It should be confirmed beforehand whether the characteristics of the LEDs will or will not be damaged by repairing.

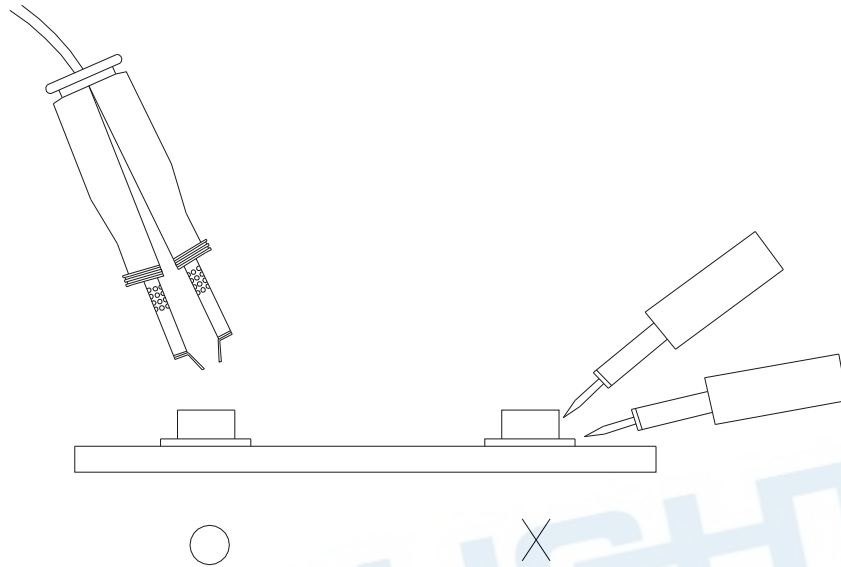

## 6.Directions for use

The LEDs should be operated with forward bias. The driving circuit must be designed so that the LEDs are not subjected to forward or reverse voltage while it is off. If reverse voltage is continuously applied to the LEDs, It may cause migration resulting in LED damage.

**EVERLIGHT ELECTRONICS CO., LTD.**  
Office: No 6-8, Zhonghua Rd., Shulin Dist.,  
New Taipei City 23860, Taiwan, R.O.C

Tel: 886-2-2685-6688  
Fax: 886-2-2685-6699  
<http://www.everlight.com>

## DISCLAIMER

1. EVERLIGHT reserves the right(s) on the adjustment of product material mix for the specification.
2. The product meets EVERLIGHT published specification for a period of twelve (12) months from date of shipment.
3. The graphs shown in this datasheet are representing typical data only and do not show guaranteed values.
4. When using this product, please observe the absolute maximum ratings and the instructions for using outlined in these specification sheets. EVERLIGHT assumes no responsibility for any damage resulting from the use of the product which does not comply with the absolute maximum ratings and the instructions included in these specification sheets.
5. These specification sheets include materials protected under copyright of EVERLIGHT. Reproduction in any form is prohibited without obtaining EVERLIGHT's prior consent.
6. This product is not intended to be used for military, aircraft, automotive, medical, life sustaining or life saving applications or any other application which can result in human injury or death. Please contact authorized Everlight sales agent for special application request.

EVERLIGHT