

SL-SMT 5.08HC/06/90 3.2SN BK BX

Weidmüller Interface GmbH & Co. KG
 Klingenbergstraße 26
 D-32758 Detmold
 Germany

www.weidmueller.com

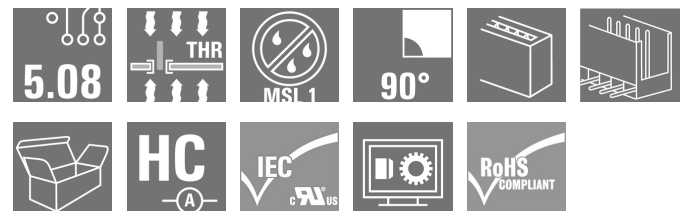

High-temperature-resistant, 90° angled, open male header. Packed in box or tape. On tape, with 1.5 mm solder pin, optimised for automatic assembly. 3.2 mm solder pin suitable for reflow and wave soldering. The pin headers provide space for labelling and can be coded. HC = High Current.

General ordering data

| | |
|--------------|---|
| Version | PCB plug-in connector, male header, open side, THT/THR solder connection, 5.08 mm, Number of poles: 6, 90°, Solder pin length (l): 3.2 mm, tinned, black, Box |
| Order No. | 1779990000 |
| Type | SL-SMT 5.08HC/06/90 3.2SN BK BX |
| GTIN (EAN) | 4032248165315 |
| Qty. | 50 pc(s). |
| Product data | IEC: 400 V / 27.5 A UL: 300 V / 18.5 A |
| Packaging | Box |

Creation date March 12, 2024 3:14:26 PM CET

SL-SMT 5.08HC/06/90 3.2SN BK BX

Weidmüller Interface GmbH & Co. KG

Klingenbergstraße 26

D-32758 Detmold

Germany

www.weidmueller.com

Technical data

Dimensions and weights

| | | | |
|--------------------------|----------|-----------------|------------|
| Depth | 12 mm | Depth (inches) | 0.472 inch |
| Height | 11.7 mm | Height (inches) | 0.461 inch |
| Height of lowest version | 8.5 mm | Width | 30.48 mm |
| Width (inches) | 1.2 inch | Net weight | 2.7 g |

System specifications

| | | | |
|--|-------------------------------------|--|---|
| Product family | OMNIMATE Signal - series BL/SL 5.08 | Type of connection | Board connection |
| Mounting onto the PCB | THT/THR solder connection | Pitch in mm (P) | 5.08 mm |
| Pitch in inches (P) | 0.2 " | Outgoing elbow | 90° |
| Number of poles | 6 | Number of solder pins per pole | 1 |
| Solder pin length (l) | 3.2 mm | Solder pin length tolerance | 0 / -0.3 mm |
| Solder pin dimensions | d = 1.2 mm, Octagonal | Solder eyelet hole diameter (D) | 1.4 mm |
| Solder eyelet hole diameter tolerance (D)+ | 0,1 mm | L1 in mm | 25.4 mm |
| L1 in inches | 1 " | Number of rows | 1 |
| Pin series quantity | 1 | Touch-safe protection acc. to DIN VDE 57 106 | finger-safe unplugged/ back-of-hand-safe plugged |
| Touch-safe protection acc. to DIN VDE 0470 | IP20 plugged/ IP10 unplugged | Protection degree | IP20 |
| Volume resistance | ≤5 mΩ | Can be coded | Yes |
| Plugging force/pole, max. | 9 N | Pulling force/pole, max. | 7 N |

Material data

| | | | |
|---------------------------------------|--------------------------------|---------------------------------------|--------------------------------|
| Insulating material | LCP GF | Colour | black |
| Colour chart (similar) | RAL 9011 | Insulating material group | IIIa |
| Comparative Tracking Index (CTI) | ≥ 175 | Moisture Level (MSL) | 1 |
| UL 94 flammability rating | V-0 | Contact material | Cu-alloy |
| Contact surface | tinned | Layer structure of solder connection | 1...3 μm Ni / 2...4 μm Sn matt |
| Layer structure of plug contact | 1...3 μm Ni / 2...4 μm Sn matt | Storage temperature, min. | -40 °C |
| Storage temperature, max. | 70 °C | Operating temperature, min. | -50 °C |
| Operating temperature, max. | 100 °C | Temperature range, installation, min. | -30 °C |
| Temperature range, installation, max. | 100 °C | | |

Rated data acc. to IEC

| | | | |
|---|------------------------|---|--------|
| tested acc. to standard | IEC 60664-1, IEC 61984 | Rated current, min. number of poles (Tu=20°C) | 27.5 A |
| Rated current, max. number of poles (Tu=20°C) | 19 A | Rated current, min. number of poles (Tu=40°C) | 24 A |
| Rated current, max. number of poles (Tu=40°C) | 16.5 A | Rated voltage for surge voltage class / pollution degree II/2 | 400 V |
| Rated voltage for surge voltage class / pollution degree III/2 | 320 V | Rated voltage for surge voltage class / pollution degree III/3 | 250 V |
| Rated impulse voltage for surge voltage class/ pollution degree II/2 | 4 kV | Rated impulse voltage for surge voltage class/ pollution degree III/2 | 4 kV |
| Rated impulse voltage for surge voltage class/ contamination degree III/3 | 4 kV | | |

SL-SMT 5.08HC/06/90 3.2SN BK BX**Weidmüller Interface GmbH & Co. KG**

Klingenbergstraße 26

D-32758 Detmold

Germany

www.weidmueller.com

Technical data**Rated data acc. to CSA**

Institute (CSA)



Certificate No. (CSA)

200039-1176845

Rated voltage (Use group B / CSA) 300 V

Rated voltage (Use group D / CSA) 300 V

Rated current (Use group B / CSA) 18.5 A

Rated current (Use group D / CSA) 18.5 A

Reference to approval values

Specifications are maximum values, details - see approval certificate.

Rated data acc. to UL 1059

Institute (UR)



Certificate No. (UR)

E60693

Rated voltage (Use group B / UL 1059) 300 V

Rated voltage (Use group D / UL 1059) 300 V

Rated current (Use group B / UL 1059) 18.5 A

Rated current (Use group D / UL 1059) 10 A

Reference to approval values

Specifications are maximum values, details - see approval certificate.

Packing

| | | | |
|-----------|-------|------------|--------|
| Packaging | Box | VPE length | 165 mm |
| VPE width | 68 mm | VPE height | 43 mm |

Classifications

| | | | |
|-------------|-------------|-------------|-------------|
| ETIM 6.0 | EC002637 | ETIM 7.0 | EC002637 |
| ETIM 8.0 | EC002637 | ETIM 9.0 | EC002637 |
| ECLASS 9.0 | 27-44-04-02 | ECLASS 9.1 | 27-44-04-02 |
| ECLASS 10.0 | 27-44-04-02 | ECLASS 11.0 | 27-46-02-01 |
| ECLASS 12.0 | 27-46-02-01 | ECLASS 13.0 | 27-46-02-01 |

SL-SMT 5.08HC/06/90 3.2SN BK BX

Weidmüller Interface GmbH & Co. KG
 Klingenbergstraße 26
 D-32758 Detmold
 Germany

www.weidmueller.com

Technical data
Important note

| | |
|----------------|--|
| IPC conformity | Conformity: The products are developed, manufactured and delivered according international recognized standards and norms and comply with the assured properties in the data sheet resp. fulfill decorative properties in accordance with IPC-A-610 "Class 2". Further claims on the products can be evaluated on request. |
| Notes | <ul style="list-style-type: none"> • Gold-plated contact surfaces on request • Rated current related to rated cross-section & min. No. of poles. • Diameter of solder eyelet D = 1.4+0.1mm • Solder eyelet diameter D = 1.5 + 0.1 mm, from 9 poles • P on drawing = pitch • Rated data refer only to the component itself. Clearance and creepage distances to other components are to be designed in accordance with the relevant application standards. • In accordance with IEC 61984, OMNIMATE-connectors are connectors without breaking capacity (COC). During designated use, connectors are not allowed to be engaged or disengaged when live or under load • Long term storage of the product with average temperature of 50 °C and maximum humidity 70%, 36 months |

Approvals

Approvals



| | |
|-----------------------|------------|
| ROHS | Conform |
| UL File Number Search | UL Website |
| Certificate No. (UR) | E60693 |

Downloads

| | |
|---|--|
| Approval/Certificate/Document of Conformity | Declaration of the Manufacturer |
| Engineering Data | CAD data – STEP |
| Catalogues | Catalogues in PDF-format |
| Brochures | FL DRIVES EN MB SMT EN FL DRIVES DE MB DEVICE MANUF. EN FL BUILDING SAFETY EN FL APPL LED LIGHTING EN FLIndustr.CONTROLS EN FL MACHINE SAFETY EN FL HEATING ELECTR EN FL APPL INVERTER EN FL BASE STATION EN FL ELEVATOR EN FL POWER SUPPLY EN FL 72H SAMPLE SER EN PO OMNIMATE EN PO OMNIMATE EN |
| White paper surface mount technology | Download Whitepaper |

Creation date March 12, 2024 3:14:26 PM CET

Catalogue status 09.03.2024 / We reserve the right to make technical changes.

SL-SMT 5.08HC/06/90 3.2SN BK BX

Weidmüller Interface GmbH & Co. KG
Klingenbergstraße 26
D-32758 Detmold
Germany

www.weidmueller.com

Drawings

Product image

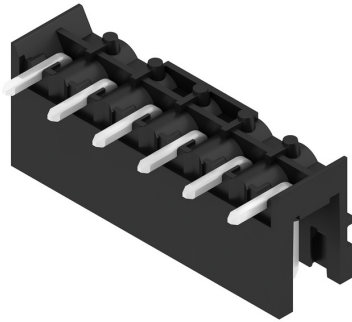

Dimensional drawing

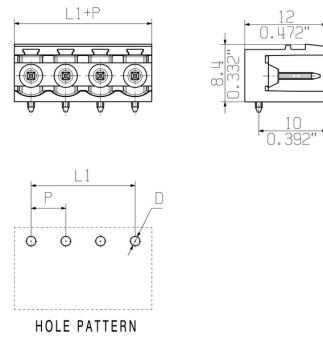

Product benefits



Safe power transmission
Proven properties

SL-SMT 5.08HC/06/90 3.2SN BK BX

Weidmüller Interface GmbH & Co. KG
Klingenbergstraße 26
D-32758 Detmold
Germany

www.weidmueller.com

Accessories

LED Light guides

**Effective: the link between LED and front panel.**

Floodlight indicators allow users to monitor the switching states without requiring a special design: optical plastic directs the light from standard LEDs around a bend into the connectors or through the front plate.

The fibre-optic elements are simply clipped behind the relevant 90° bend male connectors (90° outlet direction). Versions with different incoming light beam heights achieve maximum light efficiency for LEDs with different designs or heights.

The advantages compared to conventional solutions:

- No additional LED circuit board required behind the front panel
- No "long-legged" LEDs with separate mounting required
- Bent fibre-optic cable line for maximum light efficiency
- Uncomplicated front plate bore holes due to circular shape of outgoing light beam
- Easy to maintain correct clearance and creepage distance
- Can be partitioned for smaller pole numbers

The result: simplified manufacturing process, reduced costs and simplified design

General ordering data

| Type | SL FLA 1.5/1 | Version | Product data | Packaging |
|------------|----------------------------|---|--------------|-----------|
| Order No. | 1580100000 | PCB plug-in connector, Accessories, Flood-light display, Transparent, | | Box |
| GTIN (EAN) | 4008190152475 | Number of poles: 1 | | |
| Qty. | 100 pc(s). | | | |
| Type | SL FLA 2,3/1 | Version | Product data | Packaging |
| Order No. | 1636670000 | PCB plug-in connector, Accessories, Flood-light display, Transparent, | | Box |
| GTIN (EAN) | 4008190409975 | Number of poles: 1 | | |
| Qty. | 100 pc(s). | | | |
| Type | SL FLA 3.8/1 | Version | Product data | Packaging |
| Order No. | 1580110000 | PCB plug-in connector, Accessories, Flood-light display, Transparent, | | Box |
| GTIN (EAN) | 4008190050740 | Number of poles: 1 | | |
| Qty. | 100 pc(s). | | | |
| Type | SL FLA 3.8/24 | Version | Product data | |
| Order No. | 1595860000 | PCB plug-in connector, Accessories, Flood-light display, Transparent, | | |
| GTIN (EAN) | 4008190140892 | Number of poles: 1 | | |
| Qty. | 10 pc(s). | | | |
| Type | SL FLA 2,3/24 | Version | Product data | Packaging |
| Order No. | 1636680000 | PCB plug-in connector, Accessories, Flood-light display, Transparent, | | Box |
| GTIN (EAN) | 4008190409968 | Number of poles: 1 | | |
| Qty. | 10 pc(s). | | | |
| Type | SL FLA 1.5/24 | Version | Product data | |
| Order No. | 1595850000 | PCB plug-in connector, Accessories, Flood-light display, Transparent, | | |
| GTIN (EAN) | 4008190092573 | Number of poles: 1 | | |
| Qty. | 10 pc(s). | | | |

SL-SMT 5.08HC/06/90 3.2SN BK BX

Weidmüller Interface GmbH & Co. KG
 Klingenbergstraße 26
 D-32758 Detmold
 Germany

www.weidmueller.com

Accessories

| | | | | |
|------------|----------------------------|---|--------------|-----------|
| Type | SL FLA 9.0/24 | Version | Product data | |
| Order No. | 1595870000 | PCB plug-in connector, Accessories, Flood-light display, Transparent, | | |
| GTIN (EAN) | 4008190079796 | Number of poles: 1 | | |
| Qty. | 10 pc(s). | | | |
| Type | SL FLA 9.0/1 | Version | Product data | Packaging |
| Order No. | 1580120000 | PCB plug-in connector, Accessories, Flood-light display, Transparent, | | |
| GTIN (EAN) | 4008190031909 | Number of poles: 1 | | |
| Qty. | 100 pc(s). | | | |

Coding elements



Only connects what is supposed to be connected: the right connection at the right place.

Coding elements and locking devices clearly assign connecting elements during the manufacturing process and operation

The coding elements and locking devices are inserted prior to assembly or during the cable assembly phase. The Weidmüller alternative: configure online using the variant configurator to precode prior to delivery.

Incorrect assembly on the circuit board and incorrect plugging of connecting elements is no longer possible. The advantage: no troubleshooting during manufacture and no operational errors by the user.

General ordering data

| | | | | |
|------------|----------------------------|--|--------------|-----------|
| Type | BLZ/SL KO OR BX | Version | Product data | Packaging |
| Order No. | 1573010000 | PCB plug-in connector, Accessories, Coding element, orange, Number | | |
| GTIN (EAN) | 4008190048396 | of poles: 1 | | |
| Qty. | 100 pc(s). | | | |
| Type | BLZ/SL KO BK BX | Version | Product data | Packaging |
| Order No. | 1545710000 | PCB plug-in connector, Accessories, Coding element, black, Number | | |
| GTIN (EAN) | 4008190087142 | of poles: 1 | | |
| Qty. | 50 pc(s). | | | |

SL-SMT 5.08HC/06/90 3.2SN BK BX

Weidmüller Interface GmbH & Co. KG
 Klingenbergstraße 26
 D-32758 Detmold
 Germany

www.weidmueller.com

Accessories

Additional accessories



No task is too small when creating the perfect solution. br />

Connections form just one part of the overall process. Small details are often the key to the perfect solution in applications where potentials are tested, grouped or even isolated.

A system is not a system without small but useful details:

- Test plugs - ensure reliable pick-up from diagnostic sockets
- Cross-connectors - ensure a stable electrical distribution contact directly at the connection
- Compartment partition elements - divide a large number of male connectors into several separate socket connector channels
- Locks and clips - optional vibration-resistant clip-on connection or mounting for male and female connectors

In tandem with the manufacturing process and application - more accessories = smaller workload

General ordering data

| Type | SL AT SW | Version | Product data | Packaging |
|------------|----------------------------|--|--------------|-----------|
| Order No. | 1770240000 | PCB plug-in connector, Accessories, Spacer, black, Number of poles: 1 | | Box |
| GTIN (EAN) | 4032248117710 | | | |
| Qty. | 100 pc(s). | | | |
| Type | SL AT OR | Version | Product data | Packaging |
| Order No. | 1598300000 | PCB plug-in connector, Accessories, Spacer, orange, Number of poles: 1 | | Box |
| GTIN (EAN) | 4008190189266 | | | |
| Qty. | 100 pc(s). | | | |

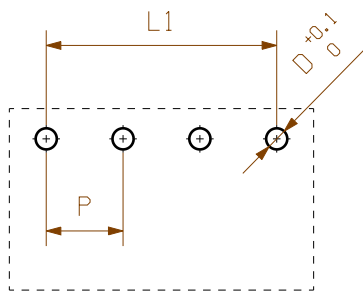
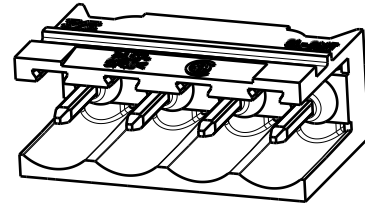
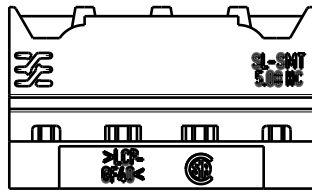
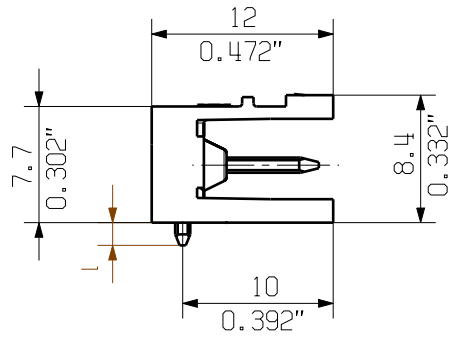
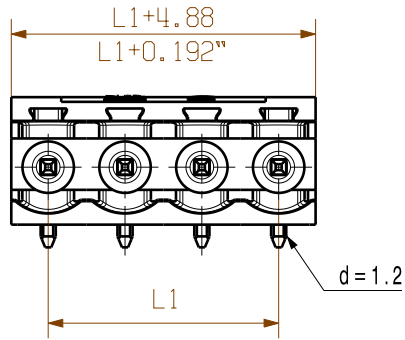

hole pattern

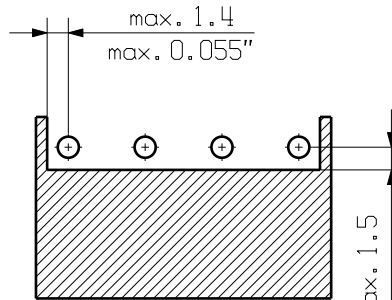

paste - free - area

| | | | |
|----|-----------|-------|----------|
| 24 | 116.84 | 4.600 | +/- 0.2 |
| 23 | 111.76 | 4.400 | |
| 22 | 106.68 | 4.200 | |
| 21 | 101.60 | 4.000 | |
| 20 | 96.52 | 3.800 | |
| 19 | 91.44 | 3.600 | +/- 0.15 |
| 18 | 86.36 | 3.400 | |
| 17 | 81.28 | 3.200 | |
| 16 | 76.20 | 3.000 | |
| 15 | 71.12 | 2.800 | |
| 14 | 66.04 | 2.600 | |
| 13 | 60.96 | 2.400 | |
| 12 | 55.88 | 2.200 | |
| 11 | 50.80 | 2.000 | +/- 0.1 |
| 10 | 45.72 | 1.800 | |
| 9 | 40.64 | 1.600 | |
| 8 | 35.56 | 1.400 | |
| 7 | 30.48 | 1.200 | |
| 6 | 25.40 | 1.000 | |
| 5 | 20.32 | 0.800 | |
| 4 | 15.24 | 0.600 | |
| 3 | 10.16 | 0.400 | |
| 2 | 5.08 | 0.200 | |
| 1 | tolerance | | |

D = 1.4/0.055" or 1.5/0.059" (REFLOW SOLDERING)
 RECOMMENDATION FOR AUTOMATIC ASSEMBLY
 (1.4mm FOR n=2...8 / 1.5mm for n=9...24)

n = Polzahl / no of poles
 P = Raster / pitch

For the mounting of PCBs, it should be noted that the rated data relates only to the PCB components alone.

The necessary creepage and clearance paths must be observed in connection with the respective applicant in accordance to IEC 664 / VDE 0110.

The current-carrying capacity and pitch tolerance is to be determined according to DIN IEC 326 part 3 very fine.

Weidmüller PCB components are tested to the DIN EN 61984 standard, and are valid for its field of application. Provided that the components are used to the intended purpose, all requirements with respect to the occurring of electrical, mechanical, thermic and corrosive stress will be satisfied.

shown: SL-SMT 5.08HC/04/90

| | |
|-----|-----------|
| 4.5 | 0.1/-0.3 |
| 3.2 | 0.1/-0.3 |
| 2.1 | 0.1/-0.3 |
| 1.5 | -0.3 |
| 1 | tolerance |

| | | | | | |
|---------------|----------------------------------|--------------------------------------|---|---|------|
| | DIN ISO 2768-m | | | Cat.no.: . | |
| | 106339/4 30.07.18 HERTEL_S 00 | | | 2 33262 31 | |
| Modification | | Drawing no. 2 33262 Issue no. | | Sheet 01 of 04 sheets | |
| | Date | Name | SL-SMT 5.08HC/.../90... STIFTLISTE MALE HEADER | | |
| | Drawn | 29.11.2007 | | | |
| Responsible | | HERTEL_S | | | |
| Checked | 01.08.2018 | KOCH_JG | | | |
| Supersedes: . | Approved | LANG_T | Product file: SL-SMT 5.08 | | 7280 |

The reproduction, distribution and utilization of this document as well as the communication of its contents without explicit authorization is prohibited. Offenders will be held liable for the payment of damages. Weidmüller exclusively reserves the right to file for patents, utility models or designs.

© Weidmüller Interface GmbH & Co. KG

Recommended wave soldering profiles

Weidmüller Interface GmbH & Co. KG
 Klängenbergstraße 16
 D-32758 Detmold
 Germany
 Fon: +49 5231 14-0
 Fax: +49 5231 14-292083
 www.weidmueller.com

Single Wave:



Double Wave:



Wave soldering profiles

Wired connection elements should be processed in accordance with the DIN EN 61760-1 standard. We have included two recommendations for practical wave soldering profiles, with which Weidmüller PCB terminals and connectors are qualified.

When choosing a suitable profile for your application, the following factors also need to be considered:

- PCB thickness
- Proportion of Cu in the layers
- Single/double-sided assembly
- Product range
- Heating and cooling rates

The single and double wave profiles each indicate the recommended operating range, including the maximum soldering temperature of 260°C. In practice, the maximum soldering temperature is quite often well below the above maximum profile.

Recommended reflow soldering profile

Weidmüller Interface GmbH & Co. KG
 Klingenbergstraße 16
 D-32758 Detmold
 Germany
 Fon: +49 5231 14-0
 Fax: +49 5231 14-292083
 www.weidmueller.com

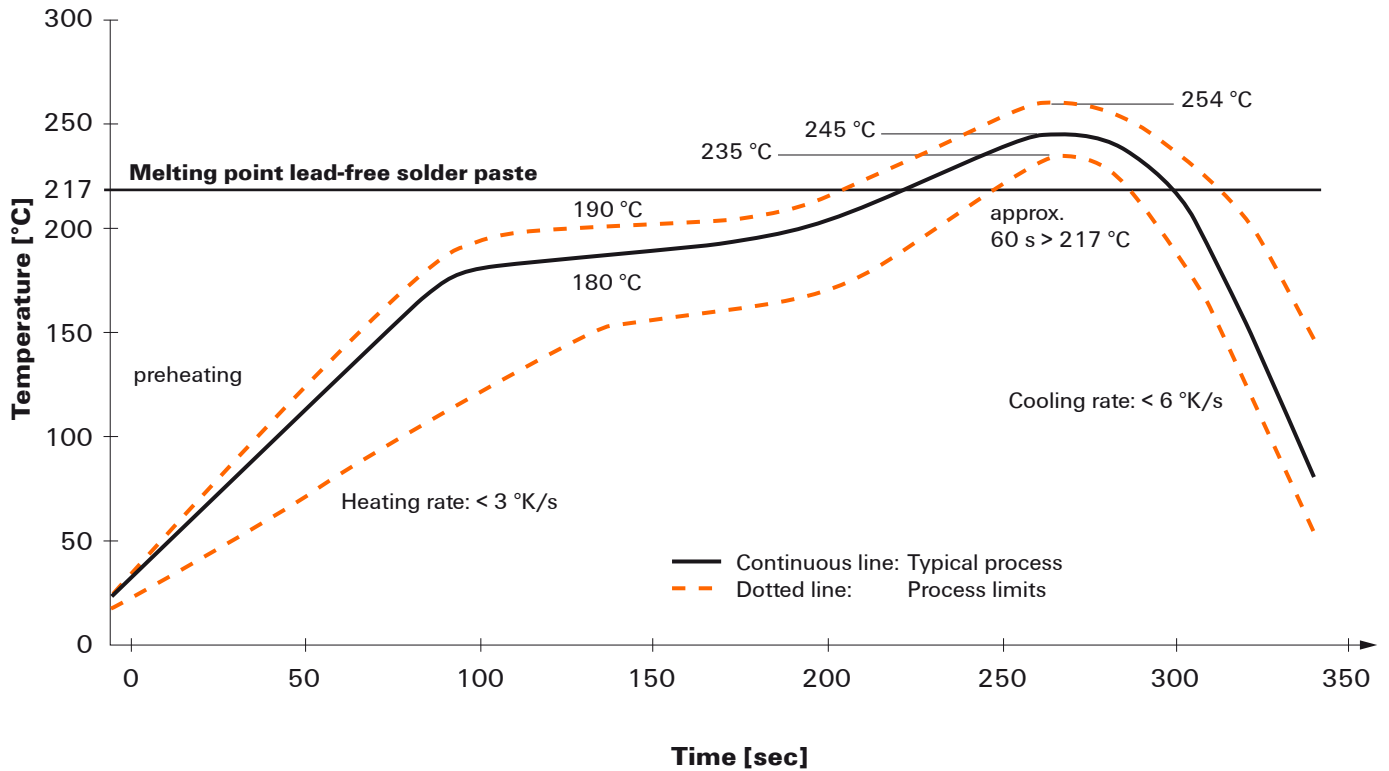

Reflow soldering profile

The perfect soldering profile for SMT Surface Mount Technology is one the most exiting question in SMT production. But there are more than one correct answer: The diagram of temperature-on-time is related to processing features of solder paste and to maximum load of components.

We have to consider the following parameters:

- Time for pre heating
- Maximum temperature
- Time above melting point
- Time for cooling
- Maximum heating rate
- Maximum cooling rate

We recommend a typical solder profile with associated process limits. With preheating components and board are prepared smoothly for the solder phase. Heating rate is typically $\leq +3\text{K/s}$. In parallel the solder paste is ‚activated‘. The time above melting point of 217°C the paste gets liquid and components and boards begin to connect. The maximum temperature of 245°C to 254°C should stay between 10 and 40 seconds. In the cooling phase at $\geq -6\text{K/s}$ solder is cured. Board and components cool down while avoiding cold cracks.