

HC-B 16-ADP/1 DSUB 50 - Adapter plate



1775538

<https://www.phoenixcontact.com/pc/products/1775538>

Please be informed that the data shown in this PDF document is generated from our Online Catalog. Please find the complete data in the user documentation. Our General Terms of Use for Downloads are valid.

D-SUB adapter plate, for one D-SUB connector, no. of positions 50, housing series HC-B 16...



Product Description

Adapter plate, incl. mounting screws

Commercial Data

Item number	1775538
Packing unit	2 pc
Minimum order quantity	2 pc
Note	Made to Order (non-returnable)
Product Key	BF7AZD
Catalog Page	Page 665 (C-2-2019)
GTIN	4017918038137
Weight per Piece (including packing)	17.37 g
Weight per Piece (excluding packing)	14.51 g
Customs tariff number	39269097
Country of origin	DE

HC-B 16-ADP/1 DSUB 50 - Adapter plate

1775538

<https://www.phoenixcontact.com/pc/products/1775538>

Technical Data

Notes

General	For housing HC-B16
---------	--------------------

Product properties

Type	B16
Product type	Adapter plate
Number of positions	50
Seal present	no

Dimensions

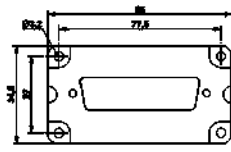
Dimensional drawing	
Width	34.5 mm
Height	10 mm
Length	85 mm

Material specifications

Color	gray
Material	PA
Flammability rating according to UL 94	HB

Environmental and real-life conditions

Ambient conditions

Ambient temperature (operation)	-20 °C ... 100 °C
---------------------------------	-------------------

Mounting

Assembly instructions	<p>Mounting screws: 1) slotted self-tapping screw 2.9 x 6.5 DIN 7971 2) M3 x 14 slotted DIN 84</p> <p>Mounting position of the adapter plate in the sleeve housing: T is visible after mounting in the housing. Mounting position of the adapter plate in the panel mounting base/socket housing/coupling housing: A is visible after mounting in the housing. Mounting position of the D-SUB (after mounting in the housing): in front of the mounting plate (front mounting)</p>
-----------------------	--

HC-B 16-ADP/1 DSUB 50 - Adapter plate



1775538

<https://www.phoenixcontact.com/pc/products/1775538>

Drawings

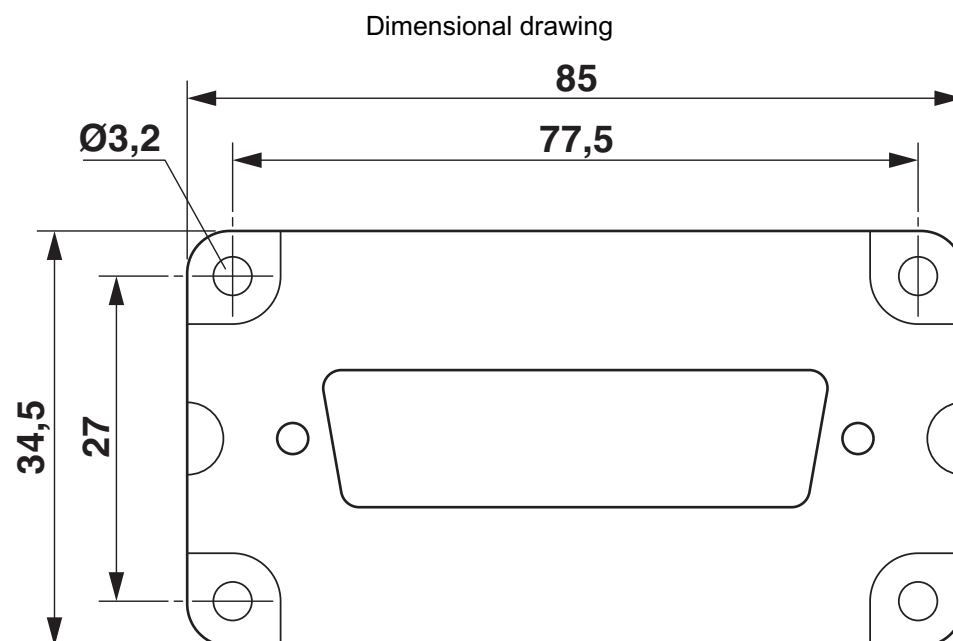

See assembly instruction

HC-B 16-ADP/1 DSUB 50 - Adapter plate

1775538

<https://www.phoenixcontact.com/pc/products/1775538>



Approvals



EAC

Approval ID: RU C-DE.AI30.B.01102

HC-B 16-ADP/1 DSUB 50 - Adapter plate



1775538

<https://www.phoenixcontact.com/pc/products/1775538>

Classifications

ECLASS

ECLASS-10.0.1	27440201
ECLASS-9.0	27440201
ECLASS-11.0	27440201
ECLASS-12.0	27440201
ECLASS-13.0	27440201

ETIM

ETIM 8.0	EC002309
----------	----------

UNSPSC

UNSPSC 21.0	31261500
-------------	----------

HC-B 16-ADP/1 DSUB 50 - Adapter plate



1775538

<https://www.phoenixcontact.com/pc/products/1775538>

Environmental Product Compliance

REACH SVHC	Lead 7439-92-1
China RoHS	Environmentally Friendly Use Period = 50 years
	For information on hazardous substances, refer to the manufacturer's declaration available under "Downloads"

Phoenix Contact 2023 © - all rights reserved

<https://www.phoenixcontact.com>

PHOENIX CONTACT GmbH & Co. KG

Flachsmarktstraße 8

D-32825 Blomberg

+49 (0) 5235-3 00

info@phoenixcontact.com