

OMNIMATE Signal - series BL/SL 5.08 SLD 5.08V/24/90B 3.2 SN OR BX

Weidmüller Interface GmbH & Co. KG
Klingenbergstraße 16
D-32758 Detmold
Germany
Fon: +49 5231 14-0
Fax: +49 5231 14-292083
www.weidmueller.com

Product image

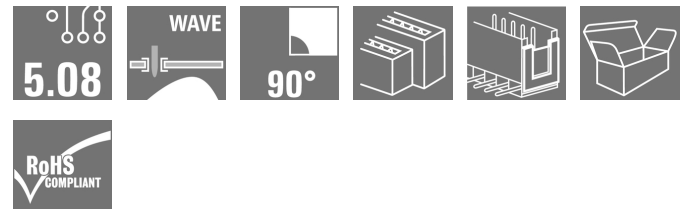

Similar to illustration

Pin headers with solder pin length optimised for wave flow soldering. The male connectors provide space for labelling and can be coded. HC = High Current.

General ordering data

| | |
|--------------|--|
| Type | SLD 5.08V/24/90B 3.2 SN OR BX |
| Order No. | 1726380000 |
| Version | PCB plug-in connector, male header, Dovetails for fixing blocks, THT solder connection, 5.08 mm, No. of poles: 24, 90°, Solder pin length (l): 3.2 mm, tinned, Orange, Box |
| GTIN (EAN) | 4032248061358 |
| Qty. | 10 pc(s). |
| Product data | IEC: 400 V / 17 A UL: 300 V / 10 A |
| Packaging | Box |

**OMNIMATE Signal - series BL/SL 5.08
SLD 5.08V/24/90B 3.2 SN OR BX**

Weidmüller Interface GmbH & Co. KG
 Klingenbergstraße 16
 D-32758 Detmold
 Germany
 Fon: +49 5231 14-0
 Fax: +49 5231 14-292083
 www.weidmueller.com

Technical data**Dimensions and weights**

| | | | |
|--------------------------|------------|-----------------|------------|
| Width | 63.5 mm | Width (inches) | 2.5 inch |
| Height | 29.4 mm | Height (inches) | 1.157 inch |
| Height of lowest version | 26.2 mm | Depth | 22.2 mm |
| Depth (inches) | 0.874 inch | Net weight | 20.001 g |

System specifications

| | | | |
|--|-------------------------------------|---------------------------------|-----------------------|
| Product family | OMNIMATE Signal - series BL/SL 5.08 | Type of connection | Board connection |
| Mounting onto the PCB | THT solder connection | Pitch in mm (P) | 5.08 mm |
| Pitch in inches (P) | 0.2 inch | Outgoing elbow | 90° |
| No. of poles | 24 | Number of solder pins per pole | 1 |
| Solder pin length (l) | 3.2 mm | Solder pin length tolerance | +0.1 / -0.3 mm |
| Tolerance of solder pin position | ± 0.15 mm | Solder pin dimensions | d = 1.2 mm, Octagonal |
| Solder pin dimensions = d tolerance | 0 / -0.03 mm | Solder eyelet hole diameter (D) | 1.3 mm |
| Solder eyelet hole diameter tolerance (D)+ | 0,1 mm | L1 in mm | 55.88 mm |
| L1 in inches | 2.2 inch | Number of rows | 2 |
| Pin series quantity | 2 | Can be coded | Yes |
| Plugging cycles | 25 | | |

Material data

| | | | |
|---------------------------------------|----------------------------|---------------------------------------|----------------------------|
| Insulating material | PBT | Colour | Orange |
| Colour chart (similar) | RAL 2000 | Insulating material group | IIIa |
| CTI | ≥ 200 | Insulation resistance | ≥ 10 ⁸ Ω |
| UL 94 flammability rating | V-0 | Contact material | CuSn |
| Contact surface | tinned | Layer structure of solder connection | 1-3 μm Ni / 2-4 μm Sn matt |
| Layer structure of plug contact | 1-3 μm Ni / 2-4 μm Sn matt | Storage temperature, min. | -25 °C |
| Storage temperature, max. | 55 °C | Max. relative humidity during storage | 80 % |
| Operating temperature, min. | -50 °C | Operating temperature, max. | 100 °C |
| Temperature range, installation, min. | -25 °C | Temperature range, installation, max. | 100 °C |

Rated data acc. to IEC

| | | | |
|---|------------------------|---|-------|
| tested acc. to standard | IEC 60664-1, IEC 61984 | Rated current, min. no. of poles (Tu=20°C) | 17 A |
| Rated current, min. no. of poles (Tu=40°C) | 15 A | Rated voltage for surge voltage class / pollution degree II/2 | 400 V |
| Rated voltage for surge voltage class / pollution degree III/2 | 320 V | Rated voltage for surge voltage class / pollution degree III/3 | 250 V |
| Rated impulse voltage for surge voltage class/ pollution degree II/2 | 4 kV | Rated impulse voltage for surge voltage class/ pollution degree III/2 | 4 kV |
| Rated impulse voltage for surge voltage class/ contamination degree III/3 | 4 kV | | |

OMNIMATE Signal - series BL/SL 5.08 SLD 5.08V/24/90B 3.2 SN OR BX

Weidmüller Interface GmbH & Co. KG
Klingenbergstraße 16
D-32758 Detmold
Germany
Fon: +49 5231 14-0
Fax: +49 5231 14-292083
www.weidmueller.com

Technical data

Rated data acc. to CSA

| | | | |
|-----------------------------------|---|-----------------------------------|----------------|
| Institute (CSA) |  | Certificate No. (CSA) | 200039-1121690 |
| Rated voltage (Use group B / CSA) | 300 V | Rated voltage (Use group D / CSA) | 300 V |
| Rated current (Use group B / CSA) | 10 A | Rated current (Use group D / CSA) | 10 A |
| Reference to approval values | Specifications are maximum values, details - see approval certificate. | | |

Rated data acc. to UL 1059

| | | | |
|---------------------------------------|---|---------------------------------------|--------|
| Institute (UR) |  | Certificate No. (UR) | E60693 |
| Rated voltage (Use group B / UL 1059) | 300 V | Rated voltage (Use group D / UL 1059) | 300 V |
| Rated current (Use group B / UL 1059) | 10 A | Rated current (Use group D / UL 1059) | 10 A |
| Reference to approval values | Specifications are maximum values, details - see approval certificate. | | |

Packaging

| | | | |
|-----------|--------|------------|--------|
| Packaging | Box | VPE length | 40 mm |
| VPE width | 125 mm | VPE height | 145 mm |

Classifications

| | | | |
|------------|-------------|------------|-------------|
| ETIM 3.0 | EC001284 | ETIM 4.0 | EC002637 |
| ETIM 5.0 | EC002637 | ETIM 6.0 | EC002637 |
| UNSPSC | 30-21-18-10 | eClass 5.1 | 27-26-07-04 |
| eClass 6.2 | 27-26-07-04 | eClass 7.1 | 27-44-04-02 |
| eClass 8.1 | 27-44-04-02 | eClass 9.0 | 27-44-04-02 |
| eClass 9.1 | 27-44-04-02 | | |

Notes

| | |
|----------------|--|
| Notes | <ul style="list-style-type: none"> • Additional colours on request • Rated current related to rated cross-section & min. No. of poles. • Spacing between rows: see hole layout • P on drawing = pitch • Rated data refer only to the component itself. Clearance and creepage distances to other components are to be designed in accordance with the relevant application standards. |
| IPC conformity | Conformity: The products are developed, manufactured and delivered according international recognized standards and norms and comply with the assured properties in the data sheet resp. fulfill decorative properties in accordance with IPC-A-610 "Class 2". Further claims on the products can be evaluated on request. |

Data sheet**OMNIMATE Signal - series BL/SL 5.08
SLD 5.08V/24/90B 3.2 SN OR BX**

Weidmüller Interface GmbH & Co. KG
Klingenbergstraße 16
D-32758 Detmold
Germany
Fon: +49 5231 14-0
Fax: +49 5231 14-292083
www.weidmueller.com

Technical data**Approvals**

Approvals



ROHS

Conform

DownloadsApproval/Certificate/Document of
Conformity[Declaration of the Manufacturer](#)

Brochure/Catalogue

[FL DRIVES EN](#)
[MB DEVICE MANUF. EN](#)
[FL DRIVES DE](#)
[FL BUILDING SAFETY EN](#)
[FL APPL LED LIGHTING EN](#)
[FLIndustr.CONTROLS EN](#)
[FL MACHINE SAFETY EN](#)
[FL HEATING ELECTR EN](#)
[FL APPL INVERTER EN](#)
[FL_BASE_STATION EN](#)
[FL ELEVATOR EN](#)
[FL POWER SUPPLY EN](#)
[FL 72H SAMPLE SER EN](#)
[PO OMNIMATE EN](#)

Engineering Data

[STEP](#)

Data sheet

**OMNIMATE Signal - series BL/SL 5.08
SLD 5.08V/24/90B 3.2 SN OR BX**

Weidmüller Interface GmbH & Co. KG
Klingenbergstraße 16
D-32758 Detmold
Germany
Fon: +49 5231 14-0
Fax: +49 5231 14-292083
www.weidmueller.com

Drawings

Dimensional drawing

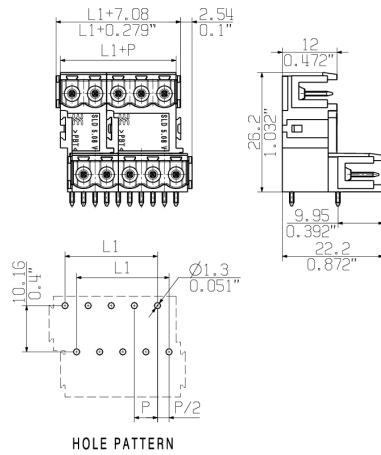

MASSE OHNE TOLERANZ SIND KEINE PRUEFMASSE
 DIMS. WITHOUT TOLERANCE ARE NOT CONTROL DIMS.

DIE DEUTSCHE VERSION IST VERBINDLICH
 THE GERMAN VERSION IS BINDING

WEITERGABE SOWIE VERVIELFAELTIGUNG DIESES DOKUMENTS, VERWERTUNG UND MITTEILUNG SEINES INHALTS SIND VERBOTEN, SOWEIT NICHT AUSDRUECKLICH GESTATTET.
 ZUWIDERHANDLUNGEN VERPFLICHTEN ZU SCHADENERSATZ. ALLE RECHTE FUER DEN FALL DER PATENT-, GEBRAUCHSMUSTER- ODER GESCHMACKSMUSTEREINTRAGUNG VORBEHALTEN.
 THE REPRODUCTION, DISTRIBUTION AND UTILIZATION OF THIS DOCUMENT AS WELL AS THE COMMUNICATION OF ITS CONTENTS TO OTHERS WITHOUT EXPLICIT AUTHORIZATION IS PROHIBITED.
 OFFENDERS WILL BE HELD LIABLE FOR THE PAYMENT OF DAMAGES. WEIDMUELLER EXCLUSIVELY RESERVES THE RIGHT TO FILE FOR PATENTS, UTILITY MODELS OR DESIGNS.
 © WEIDMUELLER INTERFACE GmbH & Co.KG

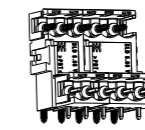
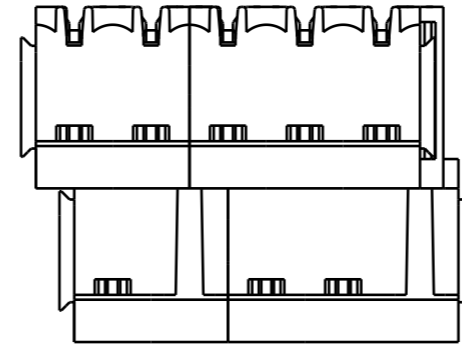
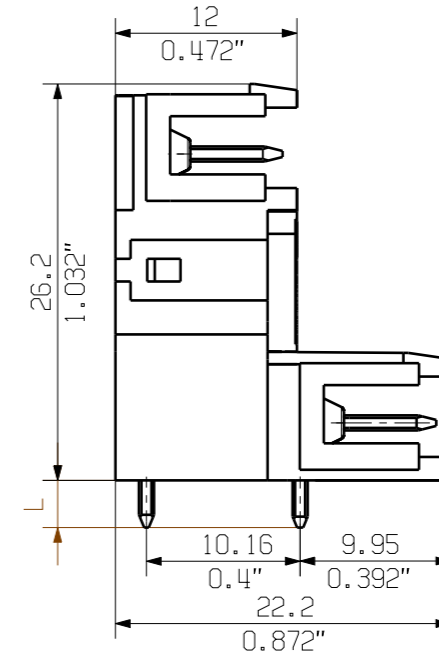
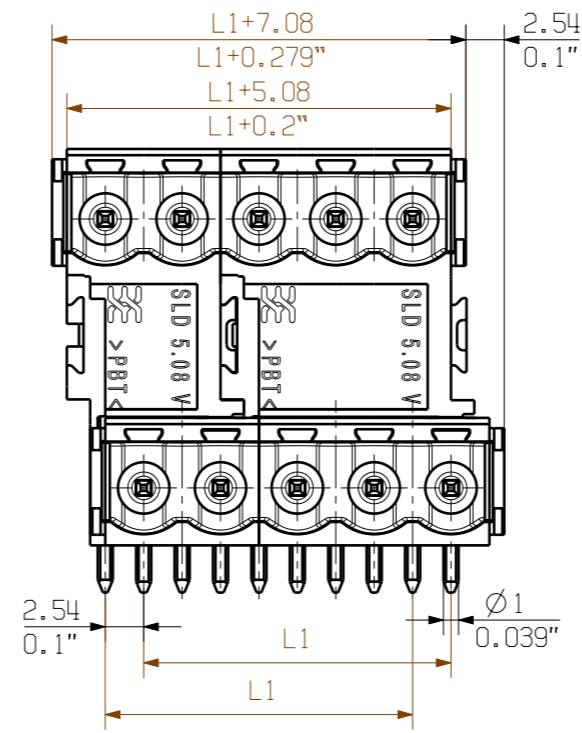

1:1

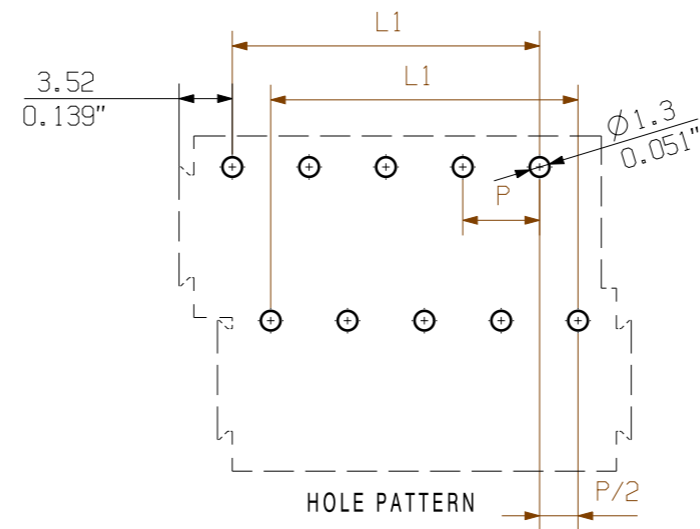

P=RASTER / PITCH
 SHOWN: SLD 5.08V/10/90B

| | | |
|----|---------|-----------|
| 48 | 116,84 | 4,600 |
| 46 | 111,76 | 4,400 |
| 44 | 106,68 | 4,200 |
| 42 | 101,60 | 4,000 |
| 40 | 96,52 | 3,800 |
| 38 | 91,44 | 3,600 |
| 36 | 86,36 | 3,400 |
| 34 | 81,28 | 3,200 |
| 32 | 76,20 | 3,000 |
| 30 | 71,12 | 2,800 |
| 28 | 66,04 | 2,600 |
| 26 | 60,96 | 2,400 |
| 24 | 55,88 | 2,200 |
| 22 | 50,80 | 2,000 |
| 20 | 45,72 | 1,800 |
| 18 | 40,64 | 1,600 |
| 16 | 35,56 | 1,400 |
| 14 | 30,48 | 1,200 |
| 12 | 25,40 | 1,000 |
| 10 | 20,32 | 0,800 |
| 8 | 15,24 | 0,600 |
| 6 | 10,16 | 0,400 |
| 4 | 5,08 | 0,200 |
| n | L1 [mm] | L1 [Inch] |

| STIFTLÄNGE L PIN LENGTH L | TOLERANZ TOLERANCE |
|------------------------------|-----------------------|
| 3,2 | 0,1 |
| | -0,3 |
| 4,5 | 0,1 |
| | -0,3 |

For the mounting of PCBs, it should be noted that the rated data relates only to the PCB components alone.
 The necessary creepage and clearance paths must be observed in connection with the respective applicant in accordance to IEC 664 / VDE 0110.
 The current-carrying capacity and pitch tolerance is to be determined according to DIN IEC 326 part 3 very fine.

Weidmüller PCB components are tested to the DIN EN 61984 standard, and are valid for its field of application.
 Provided that the components are used to the intended purpose, all requirements with respect to the occurring of electrical, mechanical, thermic and corrosive stress will be satisfied.

GENERAL TOLERANCE: DIN ISO 2768-m

84039/5
09.09.15 HELIS_MA 01

Weidmüller

CAT.NO.:

C 26660 13

DRAWING NO. SHEET 02 OF 03 SHEETS

ISSUE NO.

SCALE: 2:1

SUPERSEDES: .

DATE NAME

DRAWN 22.07.2003 KNOTH_G

RESPONSIBLE HERTEL_S

CHECKED 15.09.2015 HELIS_MA

APPROVED LANG_T

SLD 5.08V/.../90(B)...
STIFTLISTE
PIN HEADER

PRODUCT FILE: SLD 5.08V 7305

Recommended wave soldering profiles

Weidmüller Interface GmbH & Co. KG
 Klängenbergstraße 16
 D-32758 Detmold
 Germany
 Fon: +49 5231 14-0
 Fax: +49 5231 14-292083
 www.weidmueller.com

Single Wave:



Double Wave:



Wave soldering profiles

Wired connection elements should be processed in accordance with the DIN EN 61760-1 standard. We have included two recommendations for practical wave soldering profiles, with which Weidmüller PCB terminals and connectors are qualified.

When choosing a suitable profile for your application, the following factors also need to be considered:

- PCB thickness
- Proportion of Cu in the layers
- Single/double-sided assembly
- Product range
- Heating and cooling rates

The single and double wave profiles each indicate the recommended operating range, including the maximum soldering temperature of 260°C. In practice, the maximum soldering temperature is quite often well below the above maximum profile.