

MCON 1.2 mm Contact System
MCON 1.2 mm Kontaktsystem

Table of Contents

1. SCOPE	2
2. REFERENCED DOCUMENTS	
2.1 Customer Drawings.....	2
2.2 Product Specifications.....	2
2.3 Application Specification.....	2
2.4 Instruction Material.....	2
2.5 National / International Standards.....	2
3. DESCRIPTION	
3.1 Contacts with Insulation Crimp.....	2
3.2 Crimp design.....	3
4. REQUIREMENTS	
4.1 Wires.....	3
4.2 Cut-off and Burr.....	3
4.3 Wire Crimp.....	4
4.4 Insulation Crimp for Single-Wire-Seal.....	4
4.5 Contact Area.....	5
4.6 Shape and Position Tolerances.....	5
5. AUXILIARY TOOLS	
5.1 Extraction Tool.....	11
5.1.1 For Clean Body (CB) Contacts.....	11
5.1.2 For Locking Lance (LL) Contacts.....	11
5.2 Assembly Tool.....	11
FIGURES / TABLES	
Fig. 1 MCON 1.2 LL (locking lance).....	2
Fig. 2 MCON 1.2 CB (clean body).....	2
Fig. 3 Tab 1.2 mm LL (locking lance).....	2
Fig. 4 Tab 1.2 mm CB (clean body).....	2
Fig. 5 Contact with Standard Crimp.....	3
Fig. 6 Contact with Single-Seal-Crimp.....	3
Fig. 7 Shape and Position Tolerance (contact with wire insulation crimp).....	5
Fig. 8 Shape and Position Tolerance (single seal).....	5
Fig. 9-12,16 Wire and Insulation Crimp dimensions.....	6-10
Fig.13-15 Extraction Tool / Assembly Tool	11
Table 1 Crimping Data for MCON 1.2 CB (clean body).....	6
Table 2 Crimping Data for MCON 1.2 LL(locking lance).....	7
Table 3 Crimping Data for Tab 1.2 mm LL (locking lance).....	8
Table 4 Crimping Data for Tab 1.2 mm CB (clean body).....	9
Table 5 Crimping Data for MCON 1.2 LL for Tab 1,2x0,8.....	10
Revision Record	11

Inhaltsverzeichnis

1. ZWECK	2
2. ZUSÄTZLICHE UNTERLAGEN	
2.1 Kundenzeichnungen.....	2
2.2 Produktspezifikation.....	2
2.3 Verarbeitungsspezifikationen.....	2
2.4 Kundenbroschüren.....	2
2.5 Normen.....	2
3. BESCHREIBUNG	
3.1 Kontakte mit Isolationscrimp.....	2
3.2 Crimp Ausführung.....	3
4. ANFORDERUNGEN	
4.1 Leitung.....	3
4.2 Trennsteg und Grat.....	3
4.3 Drahtcrimp.....	4
4.4 Isolationscrimp für Einzeldichtung.....	4
4.5 Kontaktbereich.....	5
4.6 Form- und Lagetoleranzen.....	5
5. HILFSWERKZEUGE	
5.1 Ausdrückwerkzeug.....	11
5.1.1 Für clean body (CB) Kontakte.....	11
5.1.2 Für Locking Lance (LL) Kontakte.....	11
5.2 Montagehilfe.....	11
BILDER / TABELLEN	
Bild. 1 MCON 1.2 LL (locking lance).....	2
Bild. 2 MCON 1.2 CB (clean body).....	2
Bild. 3 Flachstecker 1.2 mm LL (locking lance).....	2
Bild. 4 Flachstecker 1.2 mm CB (clean body).....	2
Bild. 5 Kontakt mit Kontakt mit Crimp für Leitungsisolation.....	3
Bild. 6 Kontakt mit Crimp für Einzeldichtung.....	3
Bild. 7 Form- und Lagetoleranzen (Kontakt mit Crimp für Leitungsisolation).....	5
Bild. 8 Form- und Lagetoleranzen (Einzeldichtung).....	5
Bild. 9-12,16 Draht- und Iso-Crimpmaße.....	6-10
Bild. 13-15 Ausdrückwerkzeug / Montagehilfe	11
Tabelle 1 Crimpdaten für MCON 1.2 CB (clean body).....	6
Tabelle 2 Crimpdaten für MCON 1.2 LL (locking lance).....	7
Tabelle 3 Crimpdaten für Flachstecker 1.2 mm LL (locking lance).....	8
Tabelle 4 Crimpdaten für Flachstecker 1.2 mm CB (clean body).....	9
Tabelle 5 Crimpdaten für MCON 1.2 LL für Flachstecker 1,2x0,8.....	10
Änderungs- Aufzeichnung	11

1. SCOPE

This specification covers the special guidelines for the application of the MCON 1.2 contact.

2. REFERENCED DOCUMENTS

The following mentioned documents, if they are referred, are part of this specification. In case of conflict between the requirements of this specification and the product drawing or in conflict between the requirements of this specification and the referenced documents, this specification has got precedence. In case of discrepancies the German text is valid

2.1 Customer Drawings

with the measures and materials of the contacts.
1534326 1718398 1452674 1418754

2.2 Product Specification

108-18782

2.3 Application Specifications

114-18022 114-18018.

2.4 Instructional Material

<http://www.tooling.te.com/europe>

2.5 National / International Standards

DIN 72 551 Part 6/05.92 Part 5/01.92
DIN EN 60352 T2/10.02
DC Specification

3. DESCRIPTION

The terms shown below are used in the specification.

3.1 Contacts with Insulation Crimp

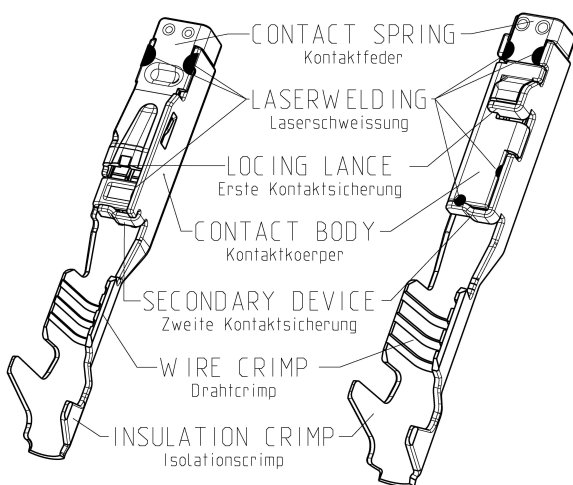

Figure 1 / Abbildung 1
MCON 1.2 LL
(locking lance)

Figure 2 / Abbildung 2
MCON 1.2 CB
(clean body)

1. ZWECK

Diese Spezifikation beinhaltet die Richtlinien zur Verarbeitung von MCON 1.2 Kontakten.

2. ZUSÄTZLICHE UNTERLAGEN

Die nachfolgend genannten Unterlagen, sofern darauf verwiesen wird, sind Teil dieser Spezifikation. Im Falle des Widerspruches zwischen dieser Spezifikation und der Produktzeichnung oder des Widerspruches zwischen dieser Spezifikation und den aufgeführten Unterlagen hat diese Spezifikation Vorrang. Im Falle von Unstimmigkeiten gilt der deutsche Text

2.1 Kundenzeichnungen

mit Maßen und Werkstoffen der Kontakte.
1534326 1718398 1452674 1418754

2.2 Produktspezifikation 1

08-18782

2.3 Verarbeitungsspezifikationen

114-18022 114-18018.

2.4 Kundenbroschüren

2.5 Nationale und internationale Normen

Unscreened low tension cables (FLR)
Solder less electrical connections,
MS-8288, MS-7889, MS-9532

3. BESCHREIBUNG

Die aufgeführten Bezeichnungen werden in der Spezifikation verwendet.

3.1 Kontakte mit Isolationscrimp

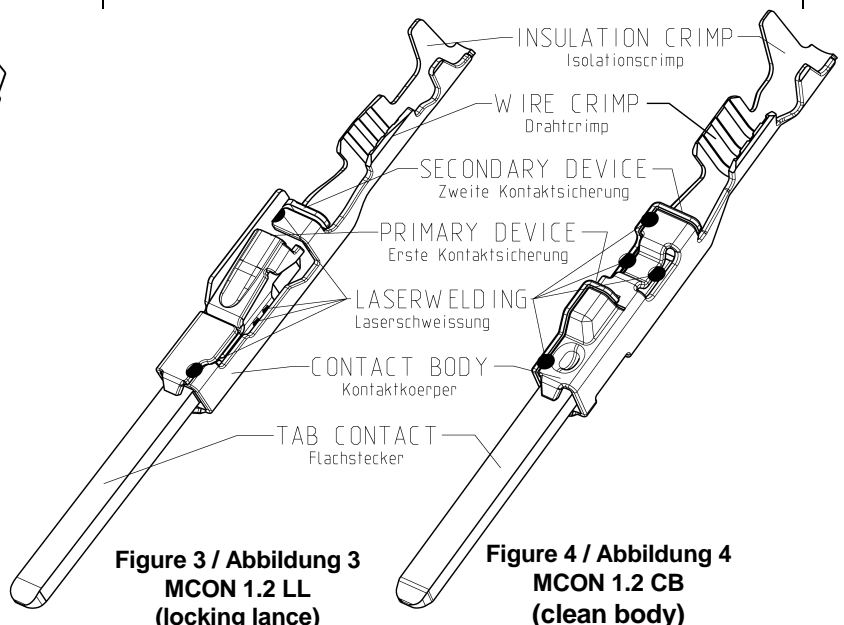

Figure 3 / Abbildung 3
MCON 1.2 LL
(locking lance)

Figure 4 / Abbildung 4
MCON 1.2 CB
(clean body)

3.2 Crimp Design

3.2.1 Contact with Wire Insulation Crimp Kontakt mit Crimp für Leitungsisolation

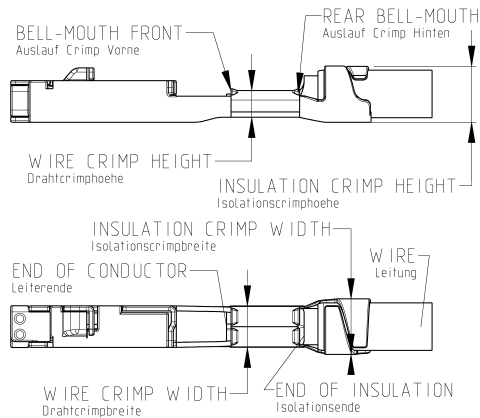

Figure 5 / Abbildung 5

3.2 Crimpausführung

3.2.2 Contact with Single-Wire Seal Crimp Kontakt mit Crimp für Einzeldichtung

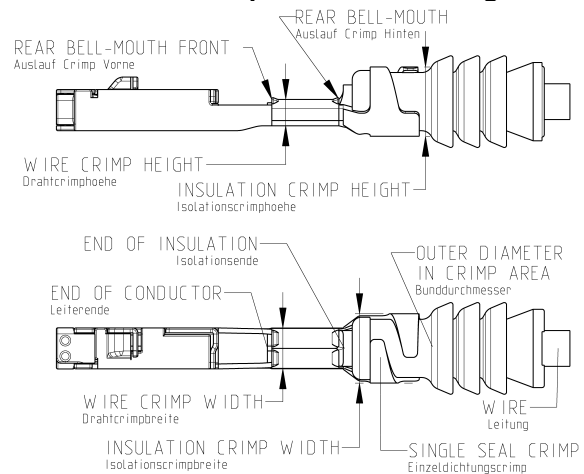

Figure 6 / Abbildung 6

4. REQUIREMENTS

4.1 Wires

A Selection

The contacts and single-wire seals are designed for FLR wires to DIN 72 551 Part 5 and Part 6.

For AWG-wire range the design considers to Chrysler-Specification: MS-8288, MS-7889, MS-9532.

Other wires require the approval of the engineering department.

Single termination is preferred.

B Preparation

The wire must be stripped to the lengths shown in tables 1-5.

Take care that the individual single strands must not be damaged, cut, or bent.

For single wire sealing, care must be taken that the insulation of the wire in the sealing area is not damaged, compressed or deformed.

The insulation must be clean and free of contamination.

4.2 Cut-off and Burr

The cutoff must be visible after crimping.

Maximum length of the cutoff is 0.3mm.

Burr at shearing point / cut-off tab 0,1mm max.

Damage to applications using family seal is to be avoided.

Cut-off tab not to be bent away from the wire.

4. ANFORDERUNGEN

4.1 Leitung

A Auswahl

Die Kontakte und Einzeldichtungen sind für FLR-Leitungen nach DIN 72 551 Teil 5 und 6 ausgelegt.

Für AWG-Leiterquerschnitte wurden die Leitungen nach Chrysler-Spezifikation berücksichtigt: MS-8288, MS-7889, MS-9532. Andere Leitungen benötigen die Freigabe der Entwicklungsabteilung. Leitungen selbst werden vorzugsweise als Einzelschläge verarbeitet.

B Vorbereitung

Die Leitung wird nach den Längenangaben in Tab.1-5 abisoliert.

Einzeldrähte dürfen dabei weder beschädigt noch aufgespleißt oder abgeschnitten werden.

Bei Verarbeitung mit Einzeldichtungen darf die Isolation im Dichtbereich nicht beschädigt oder gedrückt sein.

Die Oberfläche muss frei sein von Verunreinigungen und Rückständen.

4.2 Trennsteg und Grat

Der Trennsteg muss nach dem Crimpvorgang noch sichtbar sein.

Maximale Länge Trennsteg 0.3mm.

Trenngrat 0,1mm max.. Bei betreffenden Anwendungen ist die Beschädigung der Sammeldichtung auszuschließen. Der Trennsteg darf nicht von der Leitung abstehen.

4.3 Wire Crimp

A Wire position

After crimping, the end of the wire must extend

- 0 - max.0.2mm for
- CB contact with wire insulation crimp
- 0.1 – 0.4mm for other versions

Beyond the front end of the wire crimp.

No upcoming strands.

B Crimping data

The shape, height and width of the crimp, and the wire range, are shown in tables 1-5.

C Extraction forces

The crimp extraction forces must fulfill the requirements of DIN EN 60352 Part 2.

D Crimp bell mouth

The size of the rear bell mouth is for all wire ranges:
0.25 ± 0.1mm

A front bell mouth, at the wire crimp at the conductor end to, max. 0.1mm is allowed for CB Version with contact with wire insulation crimp. For other version a front bell mouth with max. same size of rear bell mouth is permissible.

4.4 Insulation crimp or Crimp for Single-Wire Seal

A Position of the end of the insulation

For terminals with insulation crimp (Standard crimp), the end of the insulation must be visible in the transition between the wire crimp and the insulation crimp. In no case the insulation may be crimped in the wire crimp; conversely, the insulation must extend at least to the front edge of the insulation crimp.

For terminals with single-wire sealing, the end of the insulation must be flush with the front edge of the single-wire seal or may extend up to 0.5mm from the seal.

B Crimping data for contact with wire insulation crimp

The shape and width of the crimp, and the insulation diameter, are shown in Table 1-5.

The crimp height is adjusted either according the bending test to DIN 41611 T3 or the wrap test according to DIN 41640 T66.

Small damages on the surface of the insulation may appear, especially for wire size AWG22, 0.75mm², AWG16 and 1.5mm².

C Crimping data for contact with single-wire seal crimp

The shape and width of the crimp, and the part number of the single-wire seal, are shown in Table 1-5 The crimp height is correctly adjusted if the crimp encloses the seal in the shape of a circle. Oval enclosures as the result of differing insulation diameters are permissible.

D Position of the single-wire seal

Single-wire seals without a collar on the sleeve must be flush with the front edge of the crimp or may extend up to 1 mm from the crimp. In the case of single-wire seals with a collar on the sleeve, this collar is positioned in front of the front edge of the crimp. The collar must be centered within the window on the bottom of the crimp.

4.3 Drahtcrimp

A Lage des Leiters

Das Leiterende muss nach dem Crimpen:

- 0 - max.0.2mm für
 - CB Kontakt mit Crimp für Leitungsisolation
 - 0.1 – 0.4mm für andere Varianten
- an der Vorderkante des Drahtcrimps vorstehen.

Die Litzen dürfen nicht nach oben stehen.

B Crimpdaten

Die Crimpform, Crimp Höhen und -breiten sowie Leiterquerschnitte sind in Tab.1-5 aufgeführt.

C Ausziehungswerte

Die Ausziehungswerte müssen die Anforderungen nach DIN EN 60352 Teil 2 erfüllen.

D Auslauf am Crimp

Die Größe des hinteren Auslaufs ist für alle Drahtgrößen:
0.25 ± 0.1mm

Ein vorderer Auslauf, am Drahtcrimp zum Leiterende hin, 0,1mm max. ist für CB Varianten mit Kontakt mit Crimp für Leitungsisolation erlaubt. Für andere Varianten ist ein vorderer Auslauf in max. gleicher Größe des hinteren Auslaufs zulässig.

4.4 Isolationscrimp bzw. Crimp für Einzeldichtung

A Lage des Isolationsendes

Bei Kontakten mit Crimp für Leitungsisolation muss das Isolationsende im Übergang zwischen Draht- und Isolationscrimp sichtbar sein. Das Isolationsende darf keinesfalls im Drahtcrimp untergecrimpert werden und darf umgekehrt maximal mit der Vorderkante des Isolationscrimps abschließen.

Bei Kontakten mit Crimp für Einzeldichtungen schließt das Isolationsende mit der Vorderkante der Einzeldichtung ab oder steht maximal 0.5mm vor.

B Crimpdaten für Kontakt mit Crimp für Leitungsisolation

Die Crimpform und die Crimpbreiten sowie die Isolationsdurchmesser sind in Tab.1-5 aufgeführt. Die Crimphöhe wird entweder nach der Biegeprüfung DIN 41611 T3 oder nach der Wickelprüfung DIN 41640 T66 eingestellt. Geringe Beschädigungen an der Oberfläche der Leitungsisolation können insbesondere bei Leitungsquerschnitten AWG22, 0.75mm², AWG16 und 1.5mm² auftreten.

C Crimpdaten für Kontakt mit Crimp für Einzeldichtungen

Die Crimpform und die Crimpbreiten sowie die Bestellnummer der Einzeldichtung sind in Tab.1-5 genannt. Die Crimphöhe ist optimal eingestellt, wenn der Crimp die Einzeldichtung möglichst rund umfasst. Eine ovale Umfassung aufgrund unterschiedlicher Isolationsdurchmesser ist zulässig.

D Lage der Einzeldichtung

Einzeldichtungen ohne Kragen am Bunddurchmesser schließen bündig mit der Vorderkante des Crimp ab oder stehen max. 1mm vor. Bei Einzeldichtungen mit Kragen am Bunddurchmesser liegt derselbe vor der Vorderkante des Crimp. Der Kragen ist im Fenster auf dem Crimpboden zentriert.

4.5 Contact Area

After crimping, neither the locking lances nor the contact body may be bent or deformed.

4.6 Shape and Position Tolerances

- A Contact with wire insulation crimp (Fig. 7)
- B Contact with crimp for single-wire seal (Fig. 8)
- C Data for the Step see customer drawings

4.5 Kontaktbereich

Rastfeder, und Kontaktkörper dürfen durch den Crimpvorgang weder verbogen noch deformiert sein.

4.6 Form- und Lagetoleranzen

- A Kontakt mit Crimp für Leitungsisolation (Bild 7)
- B Kontakt mit Crimp für Einzeldichtung (Bild 8)
- C Angaben für den Step siehe Kundenzeichnungen

Shape and Position Tolerances (wire insulation crimp)
Form- und Lagetoleranzen (Crimp für Leitungsisolation)

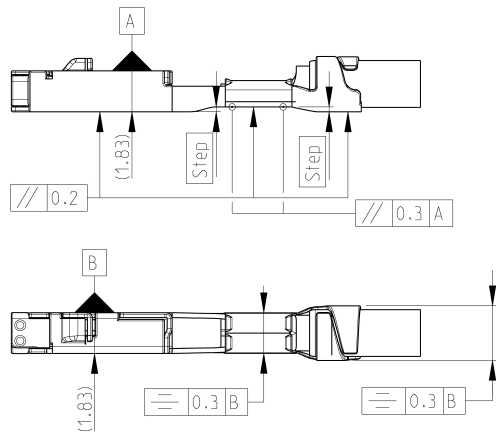

Figure 7 / Abbildung 7

Shape and Position Tolerances (Single-Wire Seal Crimp)
Form- und Lagetoleranzen (Crimp für Einzeldichtung)

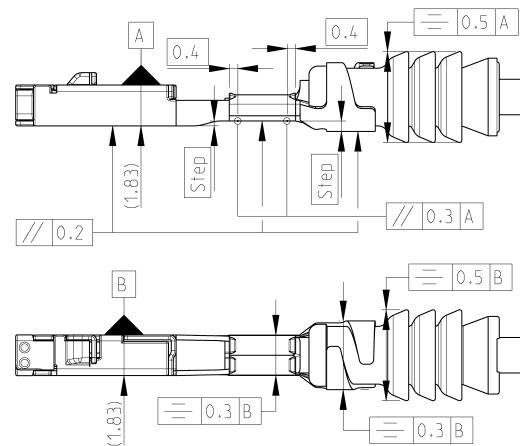
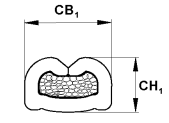
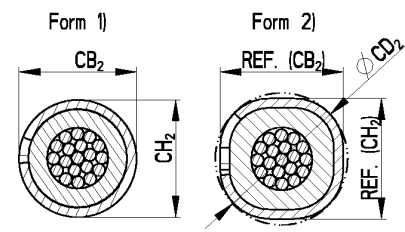

Figure 8 / Abbildung 8

MCON 1.2 CB (clean body)																															
Version / Ausführung	Order-No / Bestell-Nr.		Wire Size Range Leiter-querschnitt		Insul. Range Isolations ø (mm)	Strip Length (± 0.3) Absollerlänge	Wire Crimp / Drahtcrimp			Insulation Crimp / Iso-Crimp				Single Wire Seal For Cavity-Diameter: Einzeldichtung für Kammerdurchmesser:		Blind Plug / Blindstopfen	Master Application Tool Basis Crimp-Wkz.	Die PN for Basic-Hand tool Ergo-Crimp Matrizen PN für Basishandzg. Ergo Crimp													
	Strip Form Band-ware	Loose Piece Einzel-ware	AWG	mm²			Theoret. Width Theor. Breite (mm)	Height Höhe (mm)	Form	Width Crimp Profiles Breite Crimp profil (mm)	Max. Height Max. Höhe (mm)	Max. Width Max. Breite (mm)	Max. Crimp Surrounding circle Max. Crimp Hüllkreis (mm)	Form	ø 3.55mm				ø 3.95mm												
																				CB ₁	CH ₁	Form	CB ₂	CH ₂	CB ₂	CD ₂	Form				
Wire Insulation Crimp Crimp für Leitungsisolierung	-	-	-	0.13	0.85-1.2	-	-	-	±0.02	F	-	-	-	-	-	-	-	-													
	-	-	-	0.17			-	-											-	-	-	-	-	-	-	-	-	-	-	-	
	-	-	-	0.22			-	-											-	-	-	-	-	-	-	-	-	-	-	-	-
	1534594	1534595	24	-	1.1-1.75	2.9	1.27 (.050")	0.80	±0.03	F	1.78 (.070")	1.85	1.85	-	-	-	-	1528147	0-1579001-6												
	-	-	-	0.35				0.87												0.86	-	-									
	1394897	1534163	20	0.5	1.4-1.9	3.3	1.57 (.062")	0.98	±0.03	F	1.83 (.072")	REF. (2.05)	REF. (2.05)	2.05	-	-	-	1528148	0-1579001-5												
	-	-	-	0.75				1.09												-	-										
	1670144	1670145	20	0.5	1.4-1.9	3.3	1.57 (.062")	0.84	±0.03	F	1.83 (.072")	REF. (2.05)	REF. (2.05)	2.05	-	-	-	1528673	2-1579016-1												
	-	-	-	0.75				0.95												-	-										
	1452503	1452504	18	-	1.9-2.25	3.3	1.78 (.070")	1.11	±0.05	F	2.29 (.090")	REF. (2.45)	REF. (2.45)	2.50	-	-	-	-	1528150	1-1579001-3											
-			1.0	1.18				-													-										
16			-	2.15-2.4	3.3	1.78 (.070")	1.31	±0.05	F	2.29 (.090")	REF. (2.55)	REF. (2.55)	2.62	-	-	-	-	-	-												
-			1.5				1.36													-	-										
Single Wire Seal Crimp Crimp für Einzeldichtung	-	-	-	0.13	0.85-1.2	-	1.17 (.046")	-	±0.02	F	-	-	-	-	-	-	-	-	-												
	-	-	-	0.17			-	-												-	-	-	-	-	-	-	-	-	-	-	-
	-	-	-	0.22			-	-												-	-	-	-	-	-	-	-	-	-	-	-
	1418844	1418845	24	-	1.1-1.75	3.3	1.27 (.050")	0.80	±0.03	F	3.05 (.120")	3.2	3.2	-	-	-	-	1528152	3-1579001-9												
	-	-	-	0.35				0.87												0.86	-	-									
	1418847	1418848	20	0.5	1.4-1.9	3.6	1.57 (.062")	0.98	±0.03	F	3.18 (.125")	3.3	3.3	-	-	-	-	1528153	3-1579001-8												
	-	-	-	0.75				1.09												-	-										
	1670146	1670147	20	0.5	1.4-1.9	3.6	1.57 (.062")	0.84	±0.03	F	3.18 (.125")	3.3	3.3	-	-	-	-	1528674	2-1579016-2												
	-	-	-	0.75				0.95												-	-										
	1418850	1418851	18	-	1.9-2.4	3.6	1.78 (.070")	1.11	±0.05	F	3.3 (.130")	3.45	3.45	-	-	-	-	-	1528154	3-1579001-7											
-			1	1.18				-													-										
16			-	1.9-2.4	3.6	1.78 (.070")	1.31	±0.05	F	3.3 (.130")	3.45	3.45	-	-	-	-	-	-	-												
-			1.5				1.36													-	-										



Wire Crimp Drahtcrimp



Insulation Crimp Iso Crimp

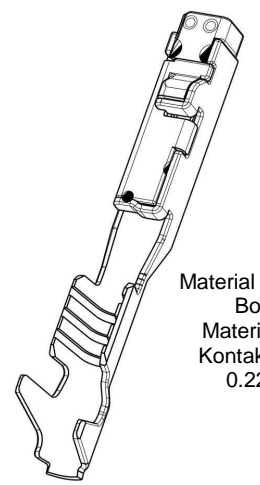

Material thickness Body / Materialdicke Kontaktkörper 0.22mm

Figure 9 Abbildung 9

1) ORDER-NO. REPLACED / Bandwaren Bestellnr. 1394897-1, -2, -3 BY / durch 1670144-1, -2, -3 AND / und 1418847-1, -2, -3 BY / durch 1670146-1, -2, -3 ersetzt
 2) In principle, the contact 1670144 can be used also on an applicator x-1528148-x (with fine adjust) (the PN 1394897) and contact 1670146 can be used also on an applicator x-1528153-x (with fine adjust) (the PN 1418847) in functionally faultless condition, the crimp height then must be adapted according to the details from table 1
 Der Kontakt 1670144 kann grundsätzlich auch auf einem Applikator x-1528148-x (mit Feineinstellung) (der PN 1394897) und 1670146 kann grundsätzlich auch, auf einem Applikator x-1528153-x (mit Feineinstellung) (der PN 1418847) in funktional einwandfreiem Zustand verwendet werden, die Crimphöhe muss dann entsprechend der Angaben aus der Tabelle 1 angepasst werden

Table 1 / Tabelle 1

MCON 1.2 LL (locking lance)																			
Version / Ausführung	Order-No / Bestell-Nr.		Wire Size Range Leiterquer-schnitt		Insul. Range Isolations ø (mm)	Strip Length (±0.3) Absollerlänge	Wire Crimp / Drahtcrimp			Insulation Crimp / Iso-Crimp				Single Wire Seal for Cavity-Diameter: Einzeldichtung für Kammerdurchmesser:		Blind Plug / Blindstopfen	Master Application Tool Basis Crimp-Wkz.	Die PN for Basic-Hand tool Ergo-Crimp Matrizen PN für Basishandzg. Ergo Crimp	
	Strip Form Band-ware	Loose Piece Einzel-ware	AWG	mm ²			Theoret. Width Theor. Breite (mm)	Height Höhe (mm)	Form	Width Crimp Profile Breite Crimp-profile (mm)	Max. Height Max. Höhe (mm)	Max. Width Max. Breite (mm)	Max. Crimp Surrounding Circle Max. Crimp Hüllkreis (mm)	Form	ø 3.55mm ø 3.95mm				
															CB ₁				CH ₁
Wire Insulation Crimp Crimp für Leitungsisolaton	0-2141861	-	-	0.13 2)	0.85-1.2	3.3	1.02 (.040")	0.68	±0.02	F	1.57 (.062")	1.31	1.31	-	-	2151333	-		
			-	0.17 2)				0.70											
			-	0.22				0.74											
	x-1452653	0-1452654	24	-	1.1-1.75	3.3	1.27 (.050")	0.75	±0.03	F	1.78 (.070")	1.85	1.85	-	-	1528156	4-1579001-3		
			22	-				0.83											
	x-1452656	0-1452657	20	0.5	1.4-1.9	3.6	1.4 (.055")	0.93 1)	±0.03	F	1.83 (.072")	REF: (2.05)	REF: (2.05)	2.05	-	-	1528157	4-1579001-2	
			-	0.75				1.05 1)											
	0-1563888	0-1563889	-	0.5	1.4-1.6	3.6	1.4 (.055")	0.86	±0.03	F	1.83 (.072")	REF: (2.05)	REF: (2.05)	2.05	-	-	1528944 1157165	1-1579001-0	
	x-1452659	0-1452660	18	-	1.9-2.25	3.6	1.78 (.070")	1.05	±0.05	F	2.29 (.090")	REF: (2.45)	REF: (2.45)	2.50	-	-	1528159	4-1579001-1	
			-	1				1.10											
16			-	1.26															
-			1.5	1.31															
Single Wire Seal Crimp / Crimp für Einzeldichtung	0-2141970	-	-	0.13 2)	0.85-1.2	3.3	1.02 (.040")	0.68	±0.02	F	2.9 (.114")	3.0	3.0	-	967067-2	963142-2	2151585	-	
			-	0.17 2)				0.70											
			-	0.22				0.74											
	x-1452665	0-1452666	24	-	1.1-1.75	3.3	1.27 (.050")	0.75	±0.03	F	3.05 (.120")	3.15	3.15	-	967067-2	963142-2	1528161	4-1579001-7	
			22	-				0.83											
			7-1452668 3)	20				0.5							1.4-1.9	3.6			1.4 (.055")
	-	0.75	0.98																
	0-1452668 3)	0-1452669	20	0.5	1.4-1.9	3.6	1.4 (.055")	0.93	±0.03	F	3.18 (.125")	3.25	3.25	-	967067-1	963142-2	1528162	4-1579001-6	
	-		0.75	1.05															
	x-1452671	0-1452672	18	-	1.9-2.4	3.6	1.78 (.070")	1.05	±0.05	F	3.30 (.130")	3.4	3.4	-	967067-1	967067-1 / 963142-2 1)	1528163	4-1579001-5	
			-	1				1.10											
			16	-	1.26														
			-	1.5	1.31														

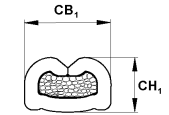

Wire Crimp Drahtcrimp

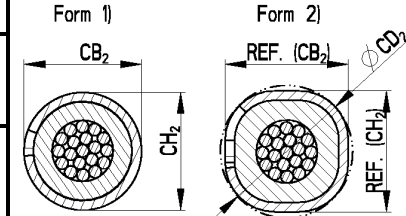

Insulation Crimp Iso Crimp

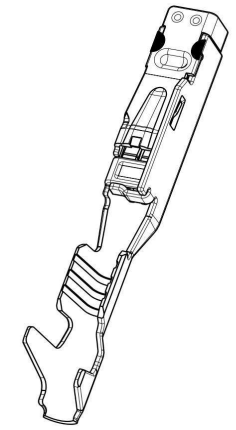
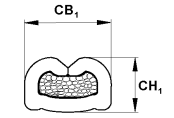

Figure 10 Abbildung 10

- 1) Seals optional, dependent on additional testing from application
Dichtung wahlweise, applikationsabhängig zu testen.
- 2) Pull reinforced wire acc. LV 112-4
Zugverstärkte Leitung nach LV 112-4
- 3) Wire crimp height variation for wire 0.75mm²
Drahtcrimphöhe variiert für Leitung 0.75mm²

Table 2 / Tabelle 2

TAB 1.2mm LL (locking lance) / Flachstecker 1.2mm LL																			
Version / Ausführung	Order-No / Bestell-Nr.		Wire Size Range Leiterquerschnitt		Insul. Range Isolations ø (mm)	Strip Length (±0.3) Absolotierlänge	Wire Crimp / Drahtcrimp			Insulation Crimp / Iso-Crimp				Single Wire Seal for Cavity-Diameter: Einzeldichtung fuer Kammerdurchmesser:		Blind Plug / Blindstopfen	Master Application Tool Basis Crimp-Wkz.	Die PN for Basic-Handtool Ergo-Crimp Matrizen PN fuer Basishandzg. Ergo Crimp	
	Strip Form Band-ware	Loose Piece Einzel-ware	AWG	mm²			Theoret. Width (mm)	Height Höhe (mm)	Form	Width Crimp Profiles Breite Crimp-profil (mm)	Max. Height Max. Höhe (mm)	Max. Width Max. Breite (mm)	Max. Crimp Surrounding circle Max. Crimp Hüllkreis (mm)	Form	ø 3.55mm				ø 3.95mm
Wire Insulation Crimp Crimp für Leitungsisolierung	0-2141864	-	-	0.13 2)	0.85-1.2	-	1.02 (.040")	0.68	±0.02	F	1.57 (.062")	1.31	1.31	-	-	2151657	-		
			-	0.17 2)				0.70											
			-	0.22				0.74											
	x-1418758	0-1418759	-	0.25	1.1-1.75	3.3	1.27 (.050")	0.78	±0.03	F	1.78 (.070")	1.75	1.75	-	-	1528428	4-1579001-3		
			24	-				0.75											
			-	0.35				0.84											
	x-1418760	0-1418761	20	0.5	1.4-1.9	3.6	1.40 (.055")	0.93 1)	±0.03	F	1.83 (.072")	REF. (2.05)	REF. (2.05)	-	-	1528506	4-1579001-2		
			-	0.75				1.05 1)											
	0-1418762	0-1418763	18	-	1.9-2.25	3.6	1.78 (.070")	1.05	±0.05	F	2.29 (.090")	REF. (2.45)	REF. (2.45)	-	-	1528507	4-1579001-1		
			-	1				1.10											
			16	-	1.26														
			-	1.5	1.31														
Single Wire Seal Crimp / Crimp für Einzeldichtung	0-2141868	-	-	0.13 2)	0.85-1.2	-	1.02 (.040")	0.68	±0.02	F	2.9 (.114")	3.0	3.0	967067-2	963142-2	2151658	-		
			-	0.17 2)				0.70											
			-	0.22				0.74											
	0-1718758	0-1718759	24	-	1.1-1.75	3.3	1.27 (.050")	0.75	±0.03	F	3.05 (.120")	3.15	3.15	967067-2	963142-2	1528509	4-1579001-7		
			-	0.35				0.84											
			22	-				0.83											
	0-1718760	0-1718761	20	0.5	1.4-1.9	3.6	1.4 (.055")	0.93	±0.03	F	3.18 (.125")	3.25	3.25	967067-1	963142-2	1528510	4-1579001-6		
			-	0.75				1.05											
	0-1718762	0-1718763	18	-	1.9-2.4	3.6	1.78 (.070")	1.05	±0.05	F	3.30 (.130")	3.4	3.4	967067-1	967067-1 / 963142-2 1)	1528511	4-1579001-5		
			-	1				1.10											
			16	-	1.26														
			-	1.5	1.31														



Wire Crimp
Drahtcrimp

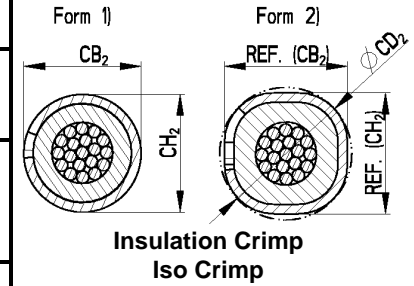

Insulation Crimp
Iso Crimp

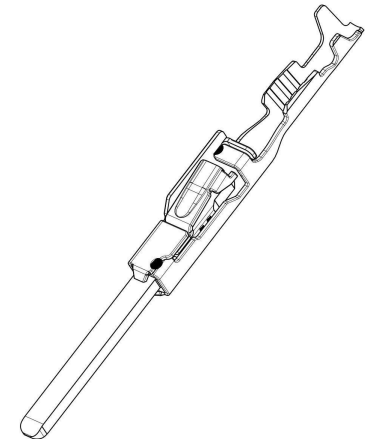

Figure 11
Abbildung 11

- 1) Seals optional, dependent on additional testing from application
Dichtung wahlweise, applikationsabhängig zu testen.
- 2) Pull reinforced wire acc. LV 112-4
Zugverstärkte Leitung nach LV 112-4

Table 3 / Tabelle 3

TAB 1.2mm CB (clean body) / Flachstecker 1.2mm CB

Version / Ausführung	Order-No / Bestell-Nr.		Wire Size Range Leiter- quer- schnitt		Insul. Range Isola- tions Ø (mm)	Strip Length (±0.3) Absolierlänge	Wire Crimp / Drahtcrimp			Insulation Crimp / Iso-Crimp				Single Wire Seal for Cavity-Diameter: Einzeldichtung für Kammer- durchmesser:		Blind Plug / Blindstopfen	Master Appli- cation Tool Basis Crimp- Wkz.	Die PN for Basic- Hand tool Ergo-Crimp Matrizen PN für Basishandzg. Ergo Crimp		
	Strip Form Band- ware	Loose Piece Einzel- ware	AWG	mm²			Theoret. Width Theor. Breite (mm)	Height Höhe (mm)	Form	Width Crimp Pro- files Breite Crimp- profile (mm) CB ₂	Max. Height Max. Höhe (mm) CH ₂	Max. Width Max. Breite (mm) CB ₂	Max. Crimp Surround- ing circle Max. Crimp Hüllkreis (mm) CD ₂	Form	Ø 3.55mm Ø 3.95mm					
															CB ₁				CH ₁	Form
Wire Insulation Crimp Crimp für Leitungsisolation	-	-	-	0.13	0.85-1.2	-	-	-	±0.02	F	-	-	-	-	-	-	-	-		
			-	0.17			-	-	-	-	-	-	-	-	-					
			-	0.22			-	-	-	-	-	-	-	-	-					
	0-1718348	-	-	-	0.25	1.1-1.75	3.3	1.27 (.050")	0.78	±0.03	F	1.78 (.070")	1.75	1.75	-	-	-	1528156	4-1579001-3	
				24	-			0.75	-	-	-	-	-	-						
				-	0.35			0.84	1.85	1.85	-	-	-	-						
				22	-			0.83	-	-	-	-	-	-						
	0-1718350	0-1718390	-	20	0.5	1.4-1.9	3.6	1.40 (.055")	0.93 1) 1.05 1)	±0.03	F	1.83 (.072")	REF. (2.05)	REF. (2.05)	2.05	-	-	1528157	4-1579001-2	
				-	0.75			-	-	-	-	-	-	-	-	-	-			
	-	-	-	18	-	1.9-2.25	3.6	1.78 (.070")	1.05	±0.05	F	2.29 (.090")	REF. (2.45)	REF. (2.45)	2.5	-	-	-	-	
-				1	1.10				REF. (2.55)				REF. (2.55)	2.62						
16				-	1.26	-			-				-	-	-					
-				1.5	1.31	-			-				-	-	-					
Single Wire Seal Crimp / Crimp für Einzeldichtung	-	-	-	0.13	0.85-1.2	3.3	1.07 (.042")	0.72	±0.03	F	3.05 (.120")	3.15	-	-	967067-2	963142-2	-	-		
			-	0.17			0.78	-	-	-	-	-	-	-	-	-				
			-	0.22			0.75	-	-	-	-	-	-	-	-	-				
	0-2208327 0-2141114	-	-	-	-	1.1-1.75	3.3	1.27 (.050")	0.84	±0.03	F	3.05 (.120")	3.15	-	-	967067-2	963142-2	2151596 (1528509)	-	
				-	0.35			0.93	-	-	-	-	-	-	-	-	-			
				-	-			0.93	-	-	-	-	-	-	-	-	-			
	0-2208328 0-2141116	-	-	-	0.5	1.4-1.9	3.6	1.4 (.055")	0.93 1) 0.98 1)	±0.03	F	3.18 (.125")	3.25	3.25	-	-	967067-1	963142-2	2151477 (1528510)	-
				-	0.75			-	-	-	-	-	-	-	-	-	-	-		
	0-2208329 0-2177610	-	-	-	-	1.9-2.4	3.6	1.78 (.070")	1.05	±0.05	F	3.30 (.130")	3.4	3.4	-	-	967067-1 / 963142-2 1)	967067-1 / 963142-2 1)	2151480 (1528511)	-
				-	1				1.10				-	-	-	-	-	-	-	-
-				-	1.26				-				-	-	-	-	-	-	-	-
-				1.5	1.31				-				-	-	-	-	-	-	-	-

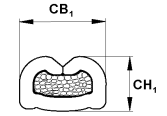

**Wire Crimp
Drahtcrimp**

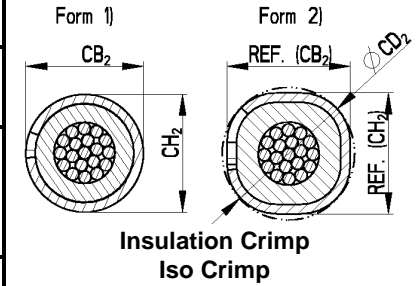

**Insulation Crimp
Iso Crimp**

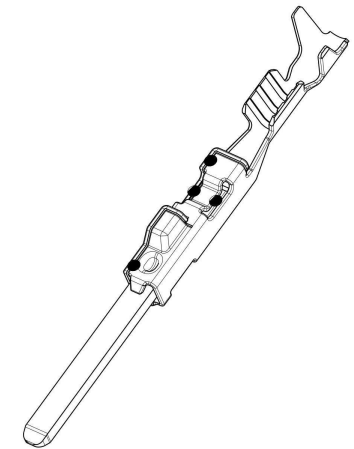

**Figure 12
Abbildung 12**

1) Seals optional, dependent on additional testing from application
Dichtung wahlweise, applikationsabhängig zu testen.

Table 4 / Tabelle 4

MCON 1.2 LL for Tab 1,2x0,8 (locking lance) #)

Version / Ausführung	Order-No / Bestell-Nr.		Wire Size Range Leiterquerschnitt		Insul. Range Isolations ø (mm)	Strip Length (±0.3) Absollänge	Wire Crimp / Drahtcrimp			Insulation Crimp / Iso-Crimp				Single Wire Seal for Cavity-Diameter: Einzeldichtung für Kammerdurchmesser:		Blind Plug / Blindstopfen	Master Application Tool Basis Crimp-Wkz.	Die PN for Basic-Hand tool Ergo-Crimp Matrizen PN für Basishandzg. Ergo Crimp		
	Strip Form Bandware	Loose Piece Einzelware	AWG	mm²			Theoret. Width Theor. Breite (mm)	Height Höhe (mm)	Form	Width Crimp Profiles Breite Crimp-profile (mm)	Max. Height Max. Höhe (mm)	Max. Width Max. Breite (mm)	Max. Crimp Surrounding Circle Max. Crimp Hüllkreis (mm)	Form	ø 3.55mm				ø 3.95mm	
																				CB ₁
Single Wire Seal Crimp / Crimp für Einzeldichtung	1718033 #)	1718034 #)	-	0.5	1.4-1.9	3.6	1.4 (.055")	0.93	±0.03	F	3.18 (.125")	3.25	3.25	-	Form 1 Wrap crimp / Umfassungscrimp	967067-1	963142-2	963143-1 (ø3.95) 967056-1 (ø3.55)	152816 2	4-1579001-6
			-	0.75			1.05													

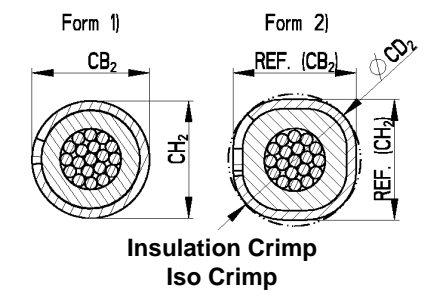
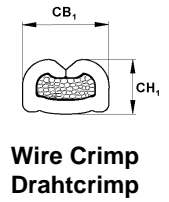

#) Kontakt ist nur für Tabs mit der Abmessung 1,2mm x 0,8mm.
Contact is only for tabs with the measurement 1,2mm x 0,8mm.

Table 5 / Tabelle 5

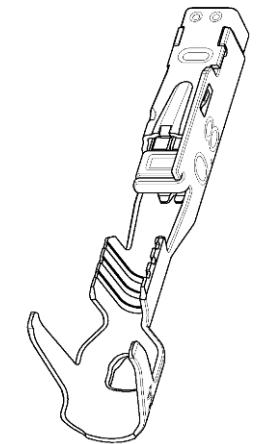

**Figure 16
Abbildung 16**

<p>6. <u>AUXILIARY TOOLS</u></p> <p><u>5.1 Extraction Tool</u></p> <p><u>5.1.1 For Clean Body Contacts</u></p> <p>The unlocking of contacts from the housing shall be done with extraction tool. For example Order-No. 8-1579008-4 (Figure 13), for detailed Information refers to application specification of the contact housing.</p> <p><u>5.1.2 For Locking Lance Contacts</u></p> <p>The unlocking of contacts from the housing shall be done with extraction tool. For example Order-No. 5-1579007-3 (Figure 14) for detailed Information refers to application specification of the contact housing.</p> <p><u>5.2 Assembly Tool</u></p> <p>If necessary, an assembly tool can be used to insert contacts with single-wire seals into the housings. Order-no. 965721-1 (Figure 15)</p>	<p>6. <u>HILFSWERKZEUGE</u></p> <p><u>5.1 Ausdrückwerkzeug</u></p> <p><u>5.1.1 Für Clean Body Kontakte</u></p> <p>Die Entriegelung der Kontakte aus den Gehäusen erfolgt mit entsprechendem Ausdrückwerkzeug. Als Beispiel ist hier die Bestell-Nr. 8-1579008-4 (Abbildung 13) genannt, genauere Angaben sind der jeweiligen Gehäuse Verarbeitungsspezifikation zu entnehmen.</p> <p><u>5.1.2 Für Locking Lance Kontakte</u></p> <p>Die Entriegelung der Kontakte aus den Gehäusen erfolgt mit dem Ausdrückwerkzeug. Als Beispiel ist hier die Bestell-Nr. 5-1579007-3 (Abbildung 14) genannt, genauere Angaben sind der jeweiligen Gehäuse Verarbeitungsspezifikation zu entnehmen.</p> <p><u>5.2 Montagehilfe</u></p> <p>Zur Gehäusebestückung von Kontakten mit Einzel-dichtung kann im Bedarfsfall eine Montagehilfe eingesetzt werden. Bestell-Nr.965721-1 (Abbildung 15)</p>
---	---

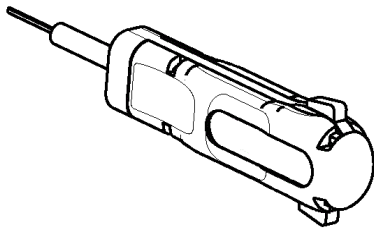

Figure 13 / Abbildung 13

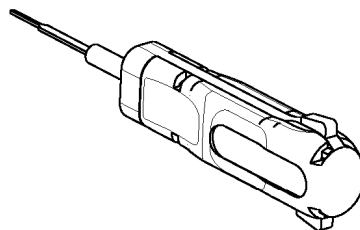

Figure 14 / Abbildung 14



Figure 15 / Abbildung 15

LTR	REVISION RECORD	DWN	APP	DATE
M	MCON 1.2 LL PN 1563888 (SHORT CIRCUIT SPRING) added Page MCON 1.2 LL for Tab 1,2x0,8 (Tables5 / Figure 16)added	R. MEIER	R. MEIER	11NOV2008
N	Update for the MCON-1.2 LL Version 7- with CuSn4 base material Variation-Seal added	R. MEIER	R. MEIER	16MAR2012
P	New PN's Tab 1.2 CB added; Update for the MCON-1.2 LL Version 7- with base material CuSn4; Update contacts for small wire sizes; Rework of the Figures	R. MEIER	V. SEIPEL	16OCT2012
DR	R. MEIER 20.04.2005	Tyco Electronics AMP GmbH a TE Connectivity Ltd. company AMPèrstraße 12-14 64625 Bensheim		
CHK	U. MÜNK 20.04.2005			
APP	NO 114-18464	REV P	LOC AI	
TITLE	MCON 1.2 MM CONTACT SYSTEM MCON 1.2 mm Kontaktsystem			