

Photovoltaic connector - PV-FT-CF-C-2,5-300-BU - 1705995

Please be informed that the data shown in this PDF Document is generated from our Online Catalog. Please find the complete data in the user's documentation. Our General Terms of Use for Downloads are valid (<http://phoenixcontact.com/download>)



Photovoltaic connector, Photovoltaic connector, housing material: PPE, color: black, number of positions: 1, min. conductor cross section: 2.5 mm², rated current: 27 A, Connection method: Crimp, Type of contact: Socket, cable length: 300. can only be released using a tool



Key Commercial Data

Packing unit	50 pc
Minimum order quantity	50 pc
GTIN	 4 046356 828321
GTIN	4046356828321
Weight per Piece (excluding packing)	15.540 g
Custom tariff number	85444290
Country of origin	Germany
Note	Made to Order (non-returnable)

Technical data

Dimensions

Fixed cable length	300 mm
External cable diameter	4.25 mm ±0.15 mm

Ambient conditions

Degree of protection (when plugged in)	IP66 / IP68 (2 m / 24 h)
Degree of protection (not plugged in)	IP20
Ambient temperature (operation)	-40 °C ... 85 °C
Ambient temperature (assembly)	-25 °C ... 50 °C

General

Design	Socket
Tightening torque nut	1.8 Nm ±0.1 Nm
Insertion force	45 N ±10 N
Disconnect force	250 N ±50 N (when locked)

Photovoltaic connector - PV-FT-CF-C-2,5-300-BU - 1705995

Technical data

General

Pull-out force of cable >= disconnect force	> 80 N
Insertion/withdrawal cycles	100
Cable cross section	2.5 mm ²
Degree of pollution	3
Degree of protection	IP20
Number of positions	1
Locking type	Latching (can only be released using tool)
Current	27 A
Rated voltage	1500 V
Rated current (2.5 mm ²)	27 A
Nominal cross section	2.5 mm ²
Protection class	II

Material

Color	black
Insulating material	mPPE
Contact material	Cu
Contact surface material	Ag
Flammability rating according to UL 94	V0

Connection data

Connection method	Crimp
Connection capacity	2.5 mm ²
Contact resistance with connected conductor	0.45 mΩ
Cable type	S01

Conductor

Outer sheath, material	PE-X
External sheath, color	blue RAL 5015
Smallest bending radius, fixed installation	21.25 mm (5x Ø)
Smallest bending radius, movable installation	40.25 mm (10x Ø)

Standards and Regulations

Flame resistance	no
Resistance to oil	no
Halogen-free	yes
Flammability rating according to UL 94	V0
Safety note	<ul style="list-style-type: none"> • WARNING: Commission properly functioning products only. The products must be regularly inspected for damage. Decommission defective products immediately. Replace damaged products. Repairs are not possible.
	<ul style="list-style-type: none"> • WARNING: Only electrically qualified personnel may install and operate the product. They must observe the following safety notes. The qualified personnel must be familiar with the basics of electrical engineering. They must be able to recognize and prevent danger. The

Photovoltaic connector - PV-FT-CF-C-2,5-300-BU - 1705995

Technical data

Standards and Regulations

	relevant symbol on the packaging indicates that only personnel familiar with electrical engineering are allowed to install and operate the product.
	WARNING: The connectors may not be plugged in or disconnected under load. Ignoring the warning or improper use may damage persons and/or property.
	<ul style="list-style-type: none"> The products are suitable for applications in plant, controller, and electrical device engineering.
	<ul style="list-style-type: none"> Assembled products may not be manipulated or improperly opened.
	<ul style="list-style-type: none"> Only use mating connectors that are specified in the technical data of the standards listed (e.g. the ones listed in the product accessories online at phoenixcontact.com/products).
	<ul style="list-style-type: none"> When using the product in direct connection with third-party manufacturers, the user is responsible.
	<ul style="list-style-type: none"> For operating voltages > 50 V AC, conductive connector housings must be grounded
	<ul style="list-style-type: none"> Ensure that the protective or functional ground has been properly connected.
	<ul style="list-style-type: none"> Observe the corresponding technical data. You will find information: <ul style="list-style-type: none"> On the product On the packing label In the supplied documentation Online at phoenixcontact.com/products under the product
	<ul style="list-style-type: none"> The installation notes/Design In documents online on the download page at phoenixcontact.com/products must be observed for this product.
	<ul style="list-style-type: none"> Use a protective cap to protect connectors that are not in use. The suitable accessories are available online in the accessory section of the product at phoenixcontact.com/products
	<ul style="list-style-type: none"> The connector warms up in normal operation. Depending on the ambient conditions, the surface of the connector can continue to warm up. In this case, the user is responsible for posting warnings (e.g. DIN EN ISO 13732-1:2008-12).
	<ul style="list-style-type: none"> Operate the connector only when it is fully plugged in and interlocked.
	<ul style="list-style-type: none"> Ensure that when laying the cable, the tensile load on the connectors does not exceed the upper limit specified in the standards.
	<ul style="list-style-type: none"> Observe the minimum bending radius of the cable. Lay the cable without twisting it.

Environmental Product Compliance

China RoHS	Environmentally friendly use period: unlimited = EFUP-e
	No hazardous substances above threshold values

Drawings

Photovoltaic connector - PV-FT-CF-C-2,5-300-BU - 1705995

Dimensional drawing

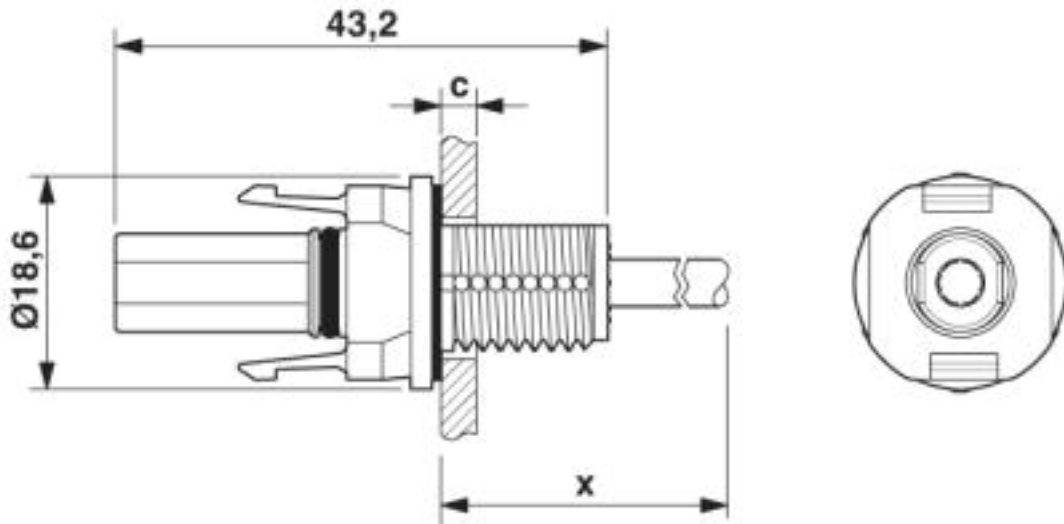

Dimension x = cable length
 c : panel thickness - plastic: 2 - 6 mm; metal: 2 - 5 mm

Dimensional drawing

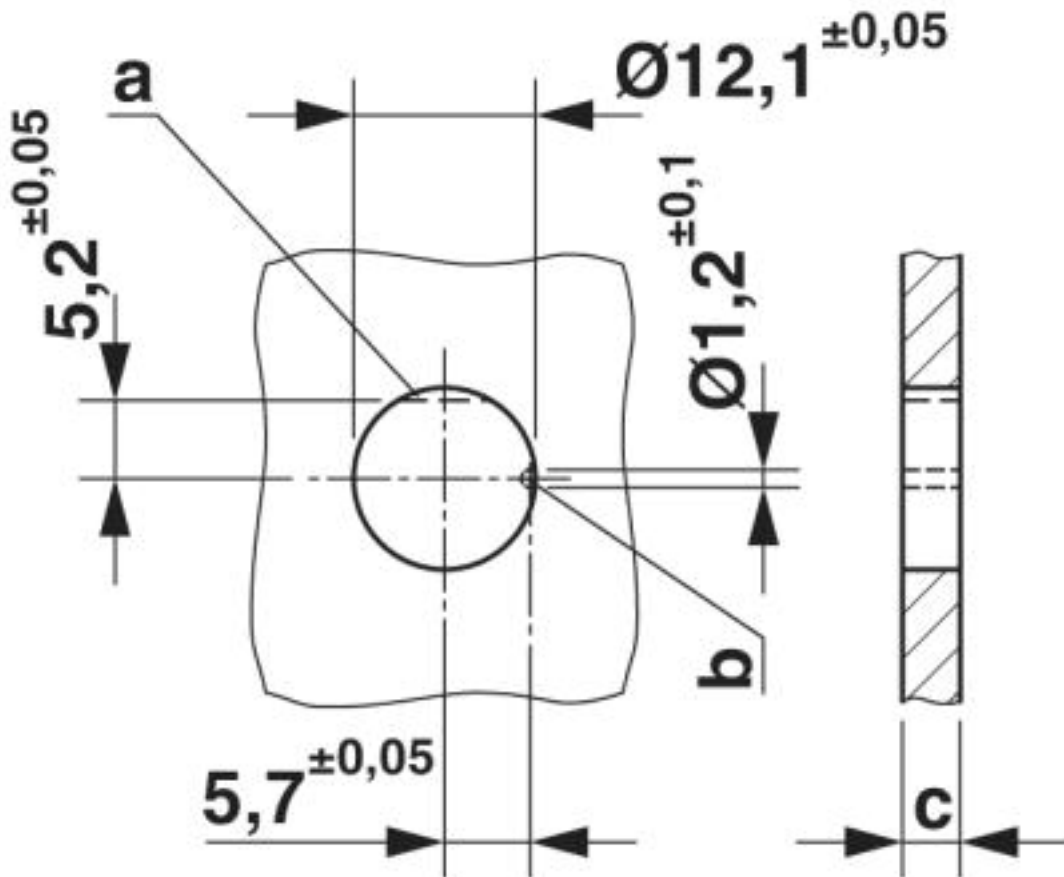

Photovoltaic connector - PV-FT-CF-C-2,5-300-BU - 1705995

Classifications

eCl@ss

eCl@ss 4.0	27260700
eCl@ss 4.1	27260700
eCl@ss 5.0	27260700
eCl@ss 5.1	27260700
eCl@ss 6.0	27260700
eCl@ss 7.0	27440102
eCl@ss 8.0	27440102
eCl@ss 9.0	27440107

ETIM

ETIM 3.0	EC001121
ETIM 4.0	EC001753
ETIM 5.0	EC002635
ETIM 6.0	EC002061

UNSPSC

UNSPSC 6.01	30211810
UNSPSC 7.0901	39121409
UNSPSC 11	39121409
UNSPSC 12.01	39121409
UNSPSC 13.2	39121413
UNSPSC 18.0	39121413
UNSPSC 19.0	39121413
UNSPSC 20.0	39121413
UNSPSC 21.0	39121413

Approvals

Approvals

Approvals

TÜV Rheinland / EAC

Ex Approvals

Approval details

Photovoltaic connector - PV-FT-CF-C-2,5-300-BU - 1705995

Approvals

TÜV Rheinland		http://www.certipedia.com	R 60126961
Nominal voltage UN		1500 V	

EAC		B.01687
-----	--	---------

Accessories

Accessories

Photovoltaic connector

Nut - PV-FT-C NUT BK - 1775880



Photovoltaic connector, Range of articles: PV-JB TF, Nut

Protective cap - PV-C PROTECTION CAP - 1785430

Photovoltaic connector, Range of articles: PV-JB TF, Protective cap, color: black, number of positions: 1

