

Type 168/185 Metallized Polyester Radial Lead Capacitors

Radial Box Metallized Polyester Capacitors for Automatic Insertion

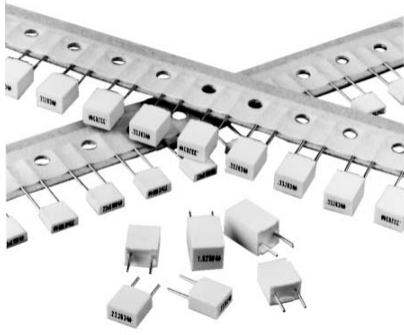

The Type 168/185 series radial lead metallized polyester box capacitors are available in bulk (Type 168) or on ammo pack or radial tape and reel (Type 185). These capacitors are constructed in rugged rectangular plastic cases and all come with 5.0 mm (0.197") lead spacing. They are good for general purpose applications such as bypass, decoupling, energy storage/discharge and arc suppression.

Highlights

- ◆ Rugged plastic case
- ◆ Case and epoxy fill meets UL94V-0
- ◆ 5.0 mm (0.197") lead spacing
- ◆ Bulk, tape and reel or ammo pack
- ◆ Non-inductively wound
- ◆ Non-polar
- ◆ Low leakage

Specifications

Capacitance Range:	0.001 μ F to 1.0 μ F
Voltage Range:	50 Vdc to 400 Vdc
Capacitance Tolerance:	\pm 5%, \pm 10%, \pm 20%
Operating Temperature Range:	-55 $^{\circ}$ C to +125 $^{\circ}$ C (with 50% Vdc derating >85 $^{\circ}$ C)
Dielectric Withstand Voltage:	1.6 x rated voltage for 2 sec @ +25 $^{\circ}$ C \pm 5 $^{\circ}$ C
Dissipation Factor (DF):	$\text{tg}\delta \times 10^{-4}$ at 25 $^{\circ}$ C \pm 5 $^{\circ}$ C

kHz	C \leq 0.1 μ F	C > 0.1 μ F
1	\leq 100	\leq 100
10	\leq 150	\leq 150
100	\leq 300	

Total Self Inductance (L): Approximately 7 nH

Long Term Stability (after two years): Capacitance change $\Delta C/C \leq \pm 3\%$ under standard environmental conditions

Maximum Pulse Rise Time (dv/dt):

Vn	V/ μ Sec
50	5
63	15
100	24
250	44
400	100

If the working voltage (V) is less than the nominal voltage (Vn), the capacitor can work at higher dv/dt. In this case, the maximum value allowed is obtained by multiplying the above value with the ratio Vn/V.

Type 168/185 Metallized Polyester Radial Lead Capacitors

Capacitor Outline Drawing

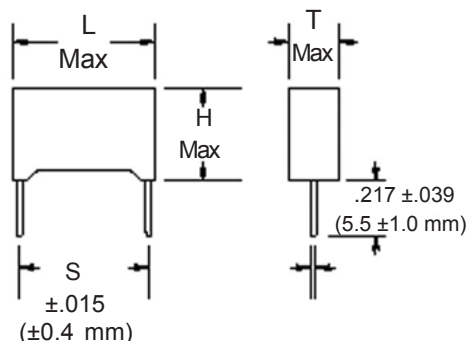

Lead length shown is as supplied on the 168 Series

Soldering	
Test Conditions	
Soldering Temperature	260 °C ±5 °C
Soldering Duration	10 sec ±1 sec
Performance	
Capacitance Change ΔC/C	≤ ±2%
DF Change Δtgδ	≤30 x 10 ⁻⁴ at 10 kHz
Insulation Resistance	≥ limit value

Test Method and Performance

Insulation Resistance	
Test Conditions	
Temperature	25 °C ±5 °C
Voltage Charge Time	1 minute
Voltage Charge	50 Vdc for Vn < 100 Vdc 100 Vdc for Vn ≥ 100 Vdc
Performance	
For Vn > 100 Vdc	≥30,000 MΩ
For Vn ≤100 Vdc	≥10,000 MΩ for C ≤ 0.1μF ≥1,000 MΩ x μF for C > 0.1μF
Damp Heat Test	
Test Conditions	
Temperature	+40 °C
Relative Humidity	95%
Test Duration	21 days
Performance	
Capacitance Change ΔC/C	≤ ±5%
DF Change Δtgδ	≤30 x 10 ⁻⁴ at 1 kHz
Insulation Resistance	≥ 50% of limit value
Life Test	
Test Conditions	
Temperature	+85 °C
Test Duration	1000 hrs
Voltage Applied	1.25 x Vn
Performance	
Capacitance Change ΔC/C	≤ ±5%
DF Change Δtgδ	≤30 x 10 ⁻⁴ at 10 kHz
Insulation Resistance	≥ 50% of limit value

Ratings

Catalog Part Number	Tape & Reel Ammo Pack	Cap (μF)	Inches					Millimeters				
			L	T	H	S	Ød	L	T	H	S	Ød
50 Vdc / 30 Vac												
168104*50A	185104*50#A>	0.10	0.283	0.098	0.256	0.197	0.024	7.2	2.5	6.5	5.0	0.6
168154*50A	185154*50#A>	0.15	0.283	0.098	0.256	0.197	0.024	7.2	2.5	6.5	5.0	0.6
168224*50C	185224*50#C>	0.22	0.283	0.138	0.295	0.197	0.024	7.2	3.5	7.5	5.0	0.6
168334*50C	185334*50#C>	0.33	0.283	0.138	0.295	0.197	0.024	7.2	3.5	7.5	5.0	0.6
168474*50H	185474*50#H>	0.47	0.283	0.177	0.335	0.197	0.024	7.2	4.5	8.5	5.0	0.6
168684*50F	185684*50#F>	0.68	0.283	0.197	0.394	0.197	0.024	7.2	5.0	10.0	5.0	0.6
168824*50G	185824*50#G>	0.82	0.283	0.236	0.433	0.197	0.024	7.2	6.0	11.0	5.0	0.6
168105*50G	185105*50#G>	1.00	0.283	0.236	0.433	0.197	0.024	7.2	6.0	11.0	5.0	0.6
63 Vdc / 40 Vac												
168473*63A	185473*63#A>	0.047	0.283	0.098	0.256	0.197	0.024	7.2	2.5	6.5	5.0	0.6
168563*63A	185563*63#A>	0.056	0.283	0.098	0.256	0.197	0.024	7.2	2.5	6.5	5.0	0.6
168683*63A	185683*63#A>	0.068	0.283	0.098	0.256	0.197	0.024	7.2	2.5	6.5	5.0	0.6
168823*63A	185823*63#A>	0.082	0.283	0.098	0.256	0.197	0.024	7.2	2.5	6.5	5.0	0.6
168104*63A	185104*63#A>	0.10	0.283	0.098	0.256	0.197	0.024	7.2	2.5	6.5	5.0	0.6
168154*63C	185154*63#C>	0.15	0.283	0.138	0.295	0.197	0.024	7.2	3.5	7.5	5.0	0.6
168184*63C	185184*63#C>	0.18	0.283	0.138	0.295	0.197	0.024	7.2	3.5	7.5	5.0	0.6
168224*63C	185224*63#C>	0.22	0.283	0.138	0.295	0.197	0.024	7.2	3.5	7.5	5.0	0.6
168274*63C	185274*63#C>	0.27	0.283	0.138	0.295	0.197	0.024	7.2	3.5	7.5	5.0	0.6
168334*63H	185334*63#H>	0.33	0.283	0.177	0.335	0.197	0.024	7.2	4.5	8.5	5.0	0.6
168474*63H	185474*63#H>	0.47	0.283	0.177	0.335	0.197	0.024	7.2	4.5	8.5	5.0	0.6
168684*63F	185684*63#F>	0.68	0.283	0.197	0.394	0.197	0.024	7.2	5.0	10.0	5.0	0.6
168105*63G	185105*63#G>	1.00	0.283	0.236	0.433	0.197	0.024	7.2	6.0	11.0	5.0	0.6

* Indicates capacitance tolerance: J = ±5%, K = ±10%, M = ±20%

Indicates packaging type: R = Tape and Reel, A = Ammo Pack

> Indicates tooling code: A = 16.5 mm, B = 18.5 mm, C = 16.0 mm (See H dimension in taping specifications)

Type 168/185 Metallized Polyester Radial Lead Capacitors

Film Capacitors

Catalog Part Number	Tape & Reel Ammo Pack	Cap (µF)	Inches					Millimeters				
			L	T	H	S	Ød	L	T	H	S	Ød
100 Vdc / 63 Vac												
168102*100A	185102*100#A>	0.0010	0.283	0.098	0.256	0.197	0.024	7.2	2.5	6.5	5.0	0.6
168152*100A	185152*100#A>	0.0015	0.283	0.098	0.256	0.197	0.024	7.2	2.5	6.5	5.0	0.6
168222*100A	185222*100#A>	0.0022	0.283	0.098	0.256	0.197	0.024	7.2	2.5	6.5	5.0	0.6
168272*100A	185272*100#A>	0.0027	0.283	0.098	0.256	0.197	0.024	7.2	2.5	6.5	5.0	0.6
168332*100A	185332*100#A>	0.0033	0.283	0.098	0.256	0.197	0.024	7.2	2.5	6.5	5.0	0.6
168392*100A	185392*100#A>	0.0039	0.283	0.098	0.256	0.197	0.024	7.2	2.5	6.5	5.0	0.6
168472*100A	185472*100#A>	0.0047	0.283	0.098	0.256	0.197	0.024	7.2	2.5	6.5	5.0	0.6
168562*100A	185562*100#A>	0.0056	0.283	0.098	0.256	0.197	0.024	7.2	2.5	6.5	5.0	0.6
168682*100A	185682*100#A>	0.0068	0.283	0.098	0.256	0.197	0.024	7.2	2.5	6.5	5.0	0.6
168822*100A	185822*100#A>	0.0082	0.283	0.098	0.256	0.197	0.024	7.2	2.5	6.5	5.0	0.6
168103*100A	185103*100#A>	0.010	0.283	0.098	0.256	0.197	0.024	7.2	2.5	6.5	5.0	0.6
168153*100A	185153*100#A>	0.015	0.283	0.098	0.256	0.197	0.024	7.2	2.5	6.5	5.0	0.6
168183*100A	185183*100#A>	0.018	0.283	0.098	0.256	0.197	0.024	7.2	2.5	6.5	5.0	0.6
168223*100A	185223*100#A>	0.022	0.283	0.098	0.256	0.197	0.024	7.2	2.5	6.5	5.0	0.6
168273*100A	185273*100#A>	0.027	0.283	0.098	0.256	0.197	0.024	7.2	2.5	6.5	5.0	0.6
168333*100C	185333*100#C>	0.033	0.283	0.138	0.295	0.197	0.024	7.2	3.5	7.5	5.0	0.6
168393*100C	185393*100#C>	0.039	0.283	0.138	0.295	0.197	0.024	7.2	3.5	7.5	5.0	0.6
168473*100C	185473*100#C>	0.047	0.283	0.138	0.295	0.197	0.024	7.2	3.5	7.5	5.0	0.6
168683*100H	185683*100#H>	0.068	0.283	0.177	0.335	0.197	0.024	7.2	4.5	8.5	5.0	0.6
168104*100H	185104*100#H>	0.10	0.283	0.177	0.335	0.197	0.024	7.2	4.5	8.5	5.0	0.6
168154*100F	185154*100#F>	0.15	0.283	0.197	0.394	0.197	0.024	7.2	5.0	10.0	5.0	0.6
168224*100G	185224*100#G>	0.22	0.283	0.236	0.433	0.197	0.024	7.2	6.0	11.0	5.0	0.6
250 Vdc / 160 Vac												
168332*250A	185332*250#A>	0.0033	0.283	0.098	0.256	0.197	0.024	7.2	2.5	6.5	5.0	0.6
168472*250A	185472*250#A>	0.0047	0.283	0.098	0.256	0.197	0.024	7.2	2.5	6.5	5.0	0.6
168682*250A	185682*250#A>	0.0068	0.283	0.098	0.256	0.197	0.024	7.2	2.5	6.5	5.0	0.6
168103*250A	185103*250#A>	0.010	0.283	0.098	0.256	0.197	0.024	7.2	2.5	6.5	5.0	0.6
168153*250A	185153*250#A>	0.015	0.283	0.098	0.256	0.197	0.024	7.2	2.5	6.5	5.0	0.6
168223*250C	185223*250#C>	0.022	0.283	0.138	0.295	0.197	0.024	7.2	3.5	7.5	5.0	0.6
168333*250C	185333*250#C>	0.033	0.283	0.138	0.295	0.197	0.024	7.2	3.5	7.5	5.0	0.6
168473*250F	185473*250#F>	0.047	0.283	0.197	0.394	0.197	0.024	7.2	5.0	10	5.0	0.6
168683*250F	185683*250#F>	0.068	0.283	0.197	0.394	0.197	0.024	7.2	5.0	10	5.0	0.6
168104*250G	185104*250#G>	0.100	0.283	0.236	0.433	0.197	0.024	7.2	6.0	11	5.0	0.6
400 Vdc / 200 Vac												
168102*400A	185102*400#A>	0.001	0.283	0.098	0.256	0.197	0.024	7.2	2.5	6.5	5.0	0.6
168152*400A	185152*400#A>	0.002	0.283	0.098	0.256	0.197	0.024	7.2	2.5	6.5	5.0	0.6
168222*400A	185222*400#A>	0.002	0.283	0.098	0.256	0.197	0.024	7.2	2.5	6.5	5.0	0.6
168332*400C	185332*400#C>	0.003	0.283	0.138	0.295	0.197	0.024	7.2	3.5	7.5	5.0	0.6
168472*400C	185472*400#C>	0.005	0.283	0.138	0.295	0.197	0.024	7.2	3.5	7.5	5.0	0.6
168682*400C	185682*400#C>	0.007	0.283	0.138	0.295	0.197	0.024	7.2	3.5	7.5	5.0	0.6
168103*400F	185103*400#F>	0.010	0.283	0.197	0.394	0.197	0.024	7.2	5.0	10	5.0	0.6
168153*400F	185153*400#F>	0.015	0.283	0.197	0.394	0.197	0.024	7.2	5.0	10	5.0	0.6
168223*400G	185223*400#G>	0.022	0.283	0.236	0.433	0.197	0.024	7.2	6.0	11	5.0	0.6

* Indicates capacitance tolerance: J = ±5%, K = ±10%, M = ±20%

Indicates packaging type: R = Tape and Reel, A = Ammo Pack

> Indicates tooling code: A = 16.5 mm, B = 18.5 mm, C = 16.0 mm (See H dimension in taping specification)