

0.8 WTB CONN.

1. PURPOSE 目的

Define the packaging specification and packaging method of 0.8 WTB.

订定 0.8 WTB 产品之包装规格及包装方式。

2. APPLICABLE PRODUCT 适用范围

Product Part No.	Description
2-1612555-0	TAB ASSY SMT-TYPE WITH EMBOSS TAPE PKG 0.8MM TO BOARD CONN
1612534-1	SLP CONNECTOR 2POS 0.8MM PITCH CONN ASSY
6612534-1/2	SLP CONNECTOR 2POS 0.8MM PITCH CONN ASSY
1759386-1	REC ASSY OFFSET TYP 0.8mm WTB 20POS CONN
1759392-1	REC ASSY ON BOARD 0.8mm WTB 20POS CONN.
1759428-1	VERICAL TYPE REC ASSY 0.8 WTB 20P

3. PACKAGING MATERIAL 包装材料

Package	Part No.	Description	Usage				
			6612534-2	2-1612555-0	1612534-1 6612534-1	1759386-1 1759392-1	1759428-1
INNER	623276-1	EMBOSS TAPE(32W)	-	28.64 MR/3500	-	-	-
	(1-1533151-5)	PS tape(32w)	-	30.072 MR/3500			
	(1-1533128-5)	PlaSTIC REEL(330X32W)	-	1/3500			
	623277-1	EMBOSS TAPE(12W)	24.704 MR/3000	-	24.704 MR/3000	-	-
	1533246-5	EMBOSS TAPE(44W)	-	-	-	24.96 MR/2000	-
	1-912125-1	EMBOSS TAPE(44W)	-	-	-	-	12.96 MR/1000
	(1-1533151-6)	PS TAPE(44W)	-	-	-	26.208 MR/2000	-
	(2-1533151-6)	PS TAPE(44W)	-	-	-	-	13.61 MR/1000
	(1533174-5)	PLASTIC REEL(380X44W)	-	-	-	1/2000	1/1000
	3-1533127-2	COVER TAPE	-	30.769 MR/3500	-	-	-
	1-1533127-2	COVER TAPE	25.704 MR/3000	-	25.704 MR/3000	-	-

DR Sam Wu	CHK Kevin Zhou	APVD Ansin Yang
--------------	-------------------	--------------------

3. PACKAGING MATERIAL 包装材料

Package	Part No.	Description	Usage				
			6612534-2	2-1612555-0	1612534-1 6612534-1	1759386-1 1759392-1	1759428-1
INNER	4-1533127-4	COVER TAPE(37.5)	-	-	-	25.96 MR/2000	15.0 MR/1000
	623868-1	CUSTOMER LABEL	1/3000	-	-	-	-
	623865-4	INNER LABEL	1/3000	1/3500	1/3000	1/2000	1/1000
MIDDLE	623880-4	AIR CAP BAG	-	-	-	4/8000	4/4000
OUTER	110455-2	BUBBLE PAD	4/21000	2/17500	4/21000	-	-
	912032-1	SHIPPING BOX	-	1/17500	-	-	-
	995838-1	SHIPPING BOX	1/21000	-	1/21000	-	-
	1-1533040-9	SHIPPING BOX(445X445X270)	-	-	-	1/8000	1/4000
	623881-5	AIR CAP	-	-	-	2/8000	2/4000
	623897-5	PAPER PAD, FOLDER	-	-	-	4/8000	4/4000
	623865-5	CUSTOMER LABEL	1/21000	-	-	-	-
623865-5	OUTER LABEL	1/21000	1/17500	1/21000	1/8000	1/4000	

	Inner	Middle	Outer
LABEL	-	623865-4	623865-5
SEALING	Tape	Tape	Tape

4. PACKAGING QUANTITY 包装数量

P/N	Inner	Middle	Outer
1612534-1 6612534-1/2	3000 pcs/reel	-	21000 pcs/box
2-1612555-0	3500 pcs/reel	-	17500 pcs/box
1759386-1 1759392-1	2000 pcs/reel	1 reel / air cap bag	8000 pcs/box
1759428-1	1000 pcs/reel	1 reel / air cap bag	4000 pcs/box

5. PACKING METHOD 包装方法

For 6612534-2:

5.1. Fix a reeler on dereeler.

将一个卷盘安装在收料器上。

注：卷盘是回收利用来料的纸卷盘。

5.2. Reel one circle cover tape and 300mm of empty EMBOSS sealed with cover tape onto reel core.

在卷盘的中心先卷一圈胶布，然后再空卷300毫米的编带和胶布。

5.3. Inner packaging specification will be fixed based on action packing machine's operation or dwg.

内包装的方法依照机器的运作或图纸要求来操作(机器运作请参照WI)。

注：1)、当达到包装数量，再让其空走完剩余的编带和胶布，然后再绕一圈胶布。

走完剩余的编带，大约400毫米。

2、包装方法(产品放入Emboss Tape 的方向及包好后产品引出的方向)请严格参照成品图纸。

5.4. Stick the end of cover tape.

用胶带贴住胶布末端。

5.5. Take off the reeler & place an inner label & customer label on the reeler full of products.

取下卷盘放好并在卷盘一侧贴一内标签和客户标签(注：覆盖来料的标签),贴法如下图1所示：



图 1

5.6. Set up a box and secure bottom flaps with tape.

折叠好一包装箱，并用胶带封住箱的底部。

5.7. Place two pieces of bubble pad into bottom of box, bubble facing down.

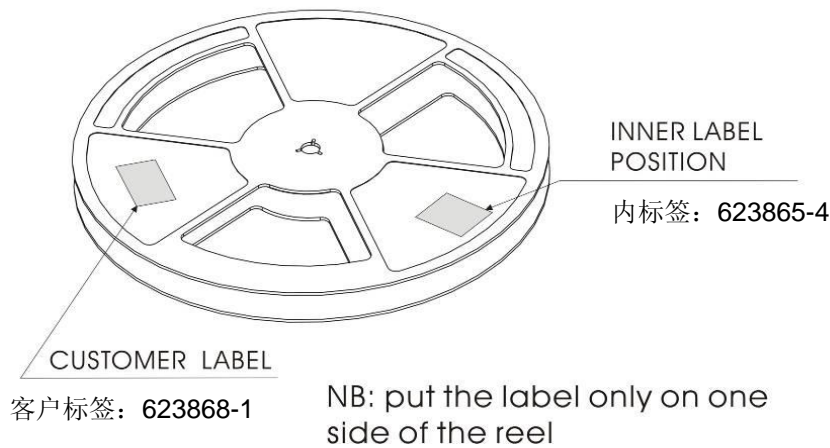
在箱底放入二块气泡垫，气泡面朝下。

5. PACKING METHOD 包装方法

5.8. Place 7 paper reeler have inner packaged into box.

放七个已包装好的卷盘放入箱中。

注：贴有标签的一面朝上。

5.9. Place two pieces of bubble pad on top of reeler, bubble facing up.

在卷盘的上面放二块气泡垫，气泡面朝上。

5.10. Seal the box with tape. And place product identification label in "product id" marked and customer label on the another side of the box(See picture 2).

用胶带封箱，在箱外印有“PRODUCT ID”标识处贴上外标签和在箱子相邻的另一侧面贴上客户标签(贴法如下图2所示)。



图 2

For 2-1612555-0; 1612534-1; 6612534-1:

5.1. Fix a reeler on dereeeler.

将一个卷盘安装在收料器上。

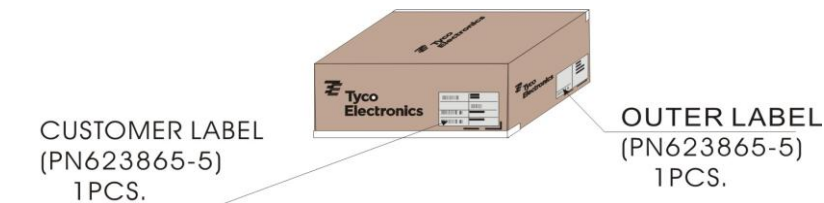
注：如果来料是小纸盘，则包装产品时用回来料的纸卷盘。

5.2. Reel one circle cover tape and 300mm of empty EMBOSS sealed with cover tape onto reel core.

在卷盘的中心先卷一圈胶布，然后再空卷300毫米的编带和胶布。

5.3. Inner packaging specification will be fixed based on action packing machine's operation or dwg.
内包装的方法依照机器的运作或图纸要求来操作(机器运作请参照WI)。

注：1)、当达到包装数量，再让其空走完剩余的编带和胶布，然后再绕一圈胶布。

For 2-1612555-0, 走完剩余的编带，大约300毫米。

For 1612534-1/6612534-1, 走完剩余的编带，大约400毫米。

2、包装方法(产品放入Emboss Tape 的方向及包好后产品引出的方向)请严格参照成品图纸。

5.4. Stick the end of cover tape.

用胶带贴住胶布末端。

5. PACKING METHOD 包装方法

5.5.2. Take off the reeler & place an inner label on the reeler full of products.

取下卷盘放好在卷盘一侧贴一内标签(注: 覆盖来料的标签)。

5.6. Set up a box and secure bottom flaps with tape.

折叠好一包装箱, 并用胶带封住箱的底部。

Only for 1612534-1/6612534-1:

5.7.1. Place two pieces of bubble pad into bottom of box, bubble facing down.

在箱底放入二块气泡垫, 气泡面朝下。

5.8.1. Place 7 paper reeler have inner packaged into box.

放七个已包装好的卷盘放入箱中。

注: 贴有标签的一面朝上。

5.9.1. Place two pieces of bubble pad on top of reeler, bubble facing up.

在卷盘的上面放二块气泡垫, 气泡面朝上。

Only for 2-1612555-0:

5.7.2. Place one piece of bubble pad into bottom of box, bubble facing down.

在箱底放入一块气泡垫, 气泡面朝下。

5.8.2. Place 5 paper reeler have inner packaged into box.

放五个已包装好的卷盘放入箱中。

注: 贴有标签的一面朝上。

5.9.2. Place one piece of bubble pad on top of reeler, bubble facing up.

在卷盘的上面放一块气泡垫, 气泡面朝上。

5.10. Seal the box with tape. And place product identification label in "product id" marked on box.

用胶带封箱, 在箱外印有“PRODUCT ID”标识处贴上外标签。

For 1759386-1;1759392-1;1759428-1:

5.1. Place one plastic reel on machine.

将一个塑料盘安装在收料器上。

5.2. Reel one circle of cover tape & 300mm of empty carrier sealed with cover tape onto reel core.

在卷盘的中心先卷一圈胶布, 然后再空卷不少于300毫米的编带和胶布。

5. PACKING METHOD 包装方法

5.3. Inner packaging specification will be fixed based on action packing machine's operation or dwg.

内包装的方法依照机器的运作或图纸要求来操作(机器运作请参照WI)。

注：1、当达到包装数量，再让其空走完剩余的编带和胶布，但至少不得少于300毫米，
然后再绕一圈胶布。

2、包装方法(产品放入Carrier Tape 的方向及包好后产品引出的方向)请严格参照成品图纸。

5.4. Stick the end of cover tape.

用皱纹纸贴住胶布末端(注：在皱纹纸的尾端反贴大约长10mm)。

5.5. Take off the plastic reel.

取下塑料盘放好。

5.6. Place an inner label on the plastic reel full of products.

在塑料盘一侧(以产品拉出时朝向操作员的一侧)贴一内标签。

5.7. Set up a box and secure bottom flaps with tape.

折叠好一包装箱，并用胶带封住箱的底部。

5.8. Set up four paper pads into triangle prism shape with tape secured and place the paper pads against the coner of shipping box.

将纸板折叠成三角形管状，并用透明胶带粘贴固定，然后将三角纸管置于纸箱四角处。

5.9. Place one piece of air cap (623881-5) in the bottom of box, bubble face down.

在箱底放一块气泡垫(623881-5)，气泡面朝下。

5.10. Place one reel into air cap bag and secure the bag opening with adhesive tape.

将已包装好的卷盘放气泡袋中，并用透明封箱胶带封住袋口。

注：贴有标签的一面朝上。

5.11. Place 4 reels wrapped in air cap bag into box.

将包好的4个卷盘置于箱中。

5.13. Place one piece of air cap (623881-5) on the top(bubble up) and close cover of the box.

在最上面放一块气泡垫(623881-5)，气泡面朝上，然后合上箱盖。

5.14. Seal the box with tape. And place product identification label in "product id" marked on box.

用胶带封箱，在箱外印有“PRODUCT ID”标识处贴上外标签。

5. PACKING METHOD 包装方法(包装示意图)

Only for 1759386-1;1759392-1;1759428-1:

