

Counter nut - A-INL-PG11-P-GY



1411223

<https://www.phoenixcontact.com/pc/products/1411223>

Please be informed that the data shown in this PDF document is generated from our Online Catalog. Please find the complete data in the user documentation. Our General Terms of Use for Downloads are valid.

Counter nut, for threads Pg11, color: silver-gray RAL 7001



Commercial Data

Item number	1411223
Packing unit	5 pc
Minimum order quantity	1 pc
Product Key	BF7DZX
Catalog Page	Page 687 (C-2-2019)
GTIN	4046356923552
Weight per Piece (including packing)	2.31 g
Weight per Piece (excluding packing)	2.04 g
Customs tariff number	39269097
Country of origin	TR

Counter nut - A-INL-PG11-P-GY

1411223

<https://www.phoenixcontact.com/pc/products/1411223>

Technical Data

Product properties

Product type	Flat nut
Thread type	Pg11

Dimensions

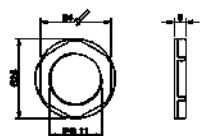
Dimensional drawing	
Length	5 mm
Connecting thread diameter	18.6 mm
Wrench size, counter nut	24 mm
Hexagon angular dimension	26 mm
Thread type connection side	Pg11

Material specifications

Color	silver-gray RAL 7001
Material	PA
Flammability rating according to UL 94	V2

Cable / line

Halogen-free	yes
--------------	-----

Environmental and real-life conditions

Ambient conditions

Ambient temperature (operation)	-40 °C ... 100 °C
---------------------------------	-------------------

Counter nut - A-INL-PG11-P-GY

1411223

<https://www.phoenixcontact.com/pc/products/1411223>



Drawings

Dimensional drawing

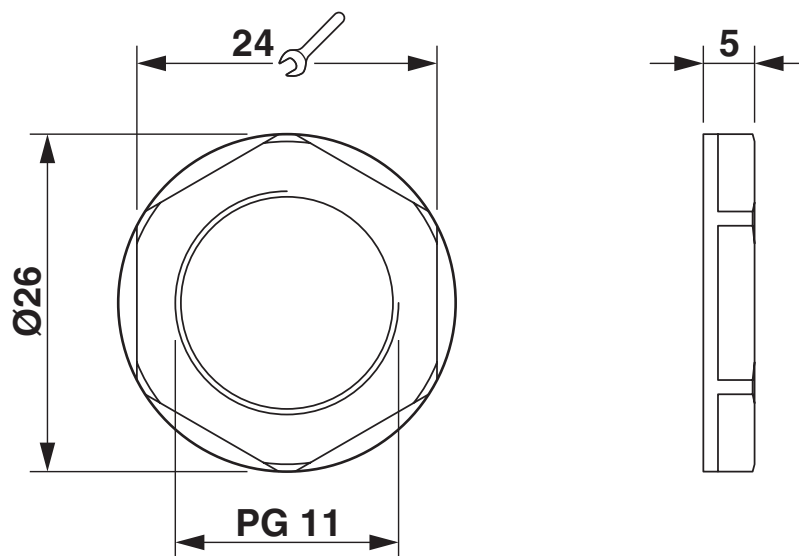

Counter nut - A-INL-PG11-P-GY



1411223

<https://www.phoenixcontact.com/pc/products/1411223>

Classifications

ECLASS

ECLASS-9.0	27144424
ECLASS-10.0.1	27144424
ECLASS-11.0	27144424

ETIM

ETIM 8.0	EC000940
----------	----------

UNSPSC

UNSPSC 21.0	31161700
-------------	----------

Counter nut - A-INL-PG11-P-GY



1411223

<https://www.phoenixcontact.com/pc/products/1411223>

Environmental Product Compliance

China RoHS	Environmentally friendly use period: unlimited = EFUP-e No hazardous substances above threshold values
------------	---

Phoenix Contact 2023 © - all rights reserved
<https://www.phoenixcontact.com>

PHOENIX CONTACT GmbH & Co. KG
Flachmarktstraße 8
D-32825 Blomberg
+49 (0) 5235-3 00
info@phoenixcontact.com