

Dimensions

1410-L110-L1F1-S01

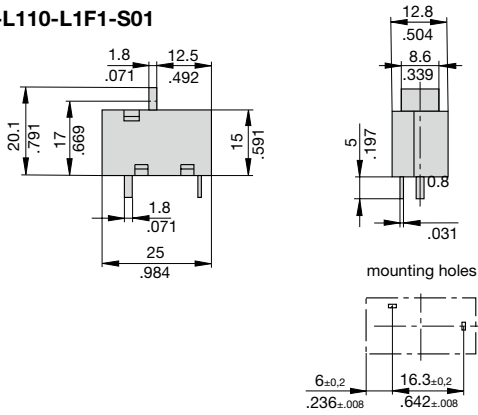

1410-L410-P3F1-E04

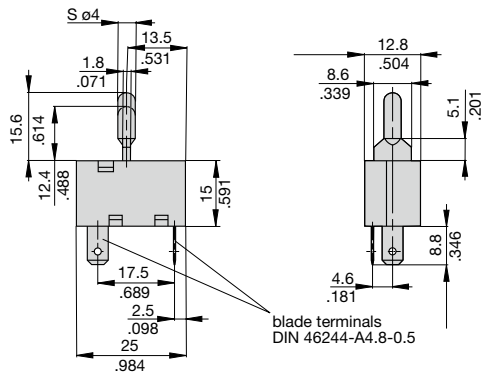

Internal connection diagram

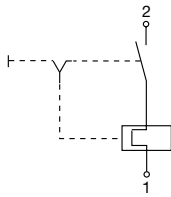

Typical time/current characteristics at +23 °C/+73.4 °F

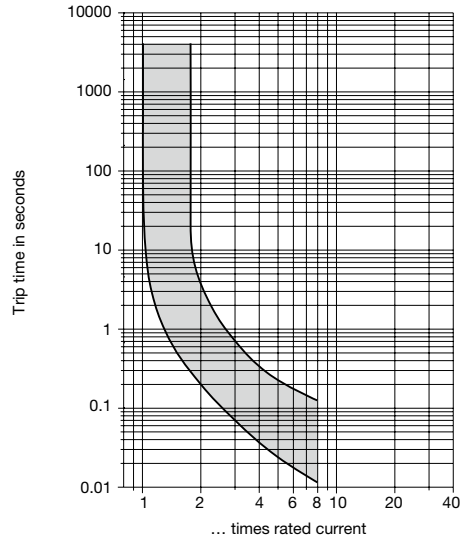

Installation drawings

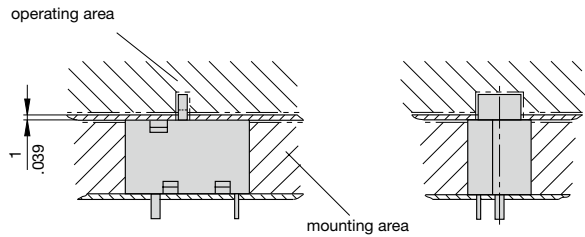

This is a metric design and millimeter dimensions take precedence ($\frac{\text{mm}}{\text{inch}}$)

All dimensions without tolerances are for reference only. In the interest of improved design, performance and cost effectiveness the right to make changes in these specifications without notice is reserved. Product markings may not be exactly as the ordering codes. Errors and omissions excepted.