

# SPE-T1-M12MS/ 2,0-99B/M12MS - Network cable



1364622

<https://www.phoenixcontact.com/de/produkte/1364622>

Please be informed that the data shown in this PDF document is generated from our online catalog. Please find the complete data in the user documentation. Our general terms of use for downloads are valid.



Network cable, Single Pair Ethernet CAT B (1 Gbps), 2-position halogen-free, shielded (Advanced Shielding Technology), Plug straight M12-SPE / IP67, on Plug straight M12-SPE / IP67, cable length: 2 m

## Product description

Single Pair Ethernet M12 patch cable

## Your advantages

- Future-proof: standardized connectors in accordance with IEC 63171-5 (IP67)
- Easily integrated: Male and female versions for established inductive sensors and flying leads
- Straightforward servicing: M12 connectors are compatible with IP20 connectors for SPE
- Safely shielded: patch cables with Advanced Shielding Technology

## Commercial data

Item number	1364622
Packing unit	1 pc
Minimum order quantity	1 pc
Note	Made to order (non-returnable)
Sales key	C1 - Sensor-Aktor-Kabel
Product key	BF1BJI
GTIN	4063151710170
Weight per piece (including packing)	130 g
Weight per piece (excluding packing)	222 g
Customs tariff number	85444290
Country of origin	PL

1364622

<https://www.phoenixcontact.com/de/produkte/1364622>

## Technical data

### Product properties

Product type	Data cable preassembled
Sensor type	Single Pair Ethernet
Number of positions	2
Application	Standard
No. of cable outlets	1
Shielded	yes

### Insulation characteristics

Overvoltage category	I
----------------------	---

### Interfaces

Bus system	Ethernet
Signal type/category	Single Pair Ethernet CAT B (ISO/IEC 63171), 1 Gbps

### Signaling

Status display	No
Status display present	No

### Electrical properties

Nominal voltage $U_N$	72 V DC
Transmission medium	Copper

### Material specifications

Flammability rating according to UL 94	V0
--	----

### Connector

#### Connection 1

Type	Plug straight M12-SPE / IP67
Shielded	yes
Insertion/withdrawal cycles	≤ 100
Degree of protection	IP67
Ambient temperature (operation)	-25 °C ... 85 °C
Insertion/withdrawal cycles	100

#### Connection 2

Type	Plug straight M12-SPE / IP67
Shielded	yes
Handle color	black
Material	CuSn (Contact) Ni/Au (Contact surface) PP (Contact carriers)

# SPE-T1-M12MS/ 2,0-99B/M12MS - Network cable



1364622

<https://www.phoenixcontact.com/de/produkte/1364622>

	TPU, hardly inflammable, self-extinguishing (Grip)
	Zinc die-cast, nickel-plated (Screw connection)
	FKM (Seal)
Insertion/withdrawal cycles	≤ 100
Ambient temperature (operation)	-25 °C ... 85 °C
Degree of protection	IP67

## Cable/line

Cable length	2 m
--------------	-----

Single Pair Ethernet PUR flexible, green [99B]

Dimensional drawing	
Cable weight	42 kg/km
UL AWM Style	20233 (80°C/300 V)
Number of positions	2
Shielded	yes
Cable type	Single Pair Ethernet PUR flexible, green [99B]
Conductor structure	1 x 2 x AWG 22/7, S/FTP
Conductor structure signal line	7x
AWG signal line	22
Conductor cross section	2x 0.34 mm <sup>2</sup>
Wire diameter incl. insulation	1.8 mm
External cable diameter	5.8 mm ±0.3 mm
Outer sheath, material	PUR
External sheath, color	green
Conductor material	Bare Cu litz wires
Material wire insulation	Foamed PE
Single wire, color	white, blue
Thickness, outer sheath	0.8 mm
Twisted pairs	2 cores to the pair
Overall twist	1 pair with fillers twisted horizontally
Optical shield covering	90 %
Insulation resistance	≥ 5 GΩ*km
Loop resistance	≤ 120.00 Ω/km
Wave impedance	100 Ω ±5 Ω (at 100 MHz)
Cable capacity	48 nF/km
Nominal voltage, cable	≤ 100 V

# SPE-T1-M12MS/ 2,0-99B/M12MS - Network cable



1364622

<https://www.phoenixcontact.com/de/produkte/1364622>

Test voltage Core/Core	1000 V (50 Hz, 1 min.)
Test voltage Core/Shield	1000 V (50 Hz, 1 min.)
Minimum bending radius, fixed installation	4 x D
Minimum bending radius, flexible installation	8 x D
Flame resistance	according to IEC 60332-1-2
Resistance to oil	in accordance with DIN EN 60811-404
Ambient temperature (operation)	-40 °C ... 80 °C (cable, fixed installation)
	-25 °C ... 80 °C (Cable, flexible installation)
	-25 °C ... 80 °C (for installation)

## Environmental and real-life conditions

### Ambient conditions

Degree of protection	IP65
	IP67

## Standards and regulations

Standard designation	M12 connector
Standards/specifications	IEC 63171-5
Note	T1-SPE

## Drawings

Schematic diagram

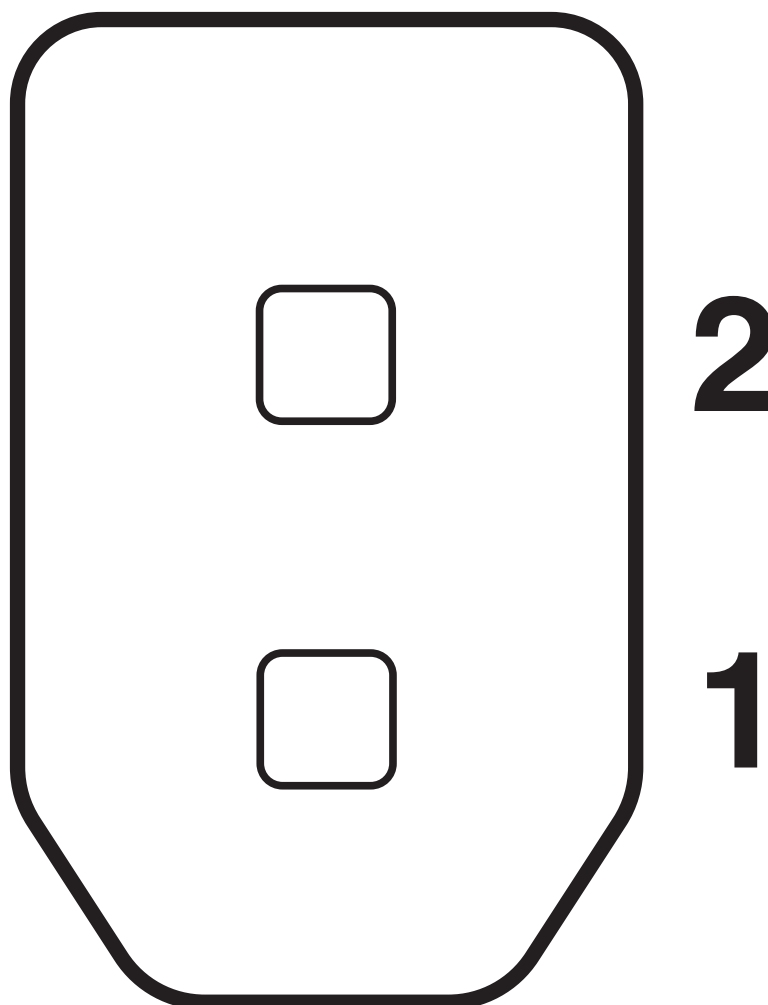

Pin assignment, Single Pair Ethernet, 2 pos.

Dimensional drawing

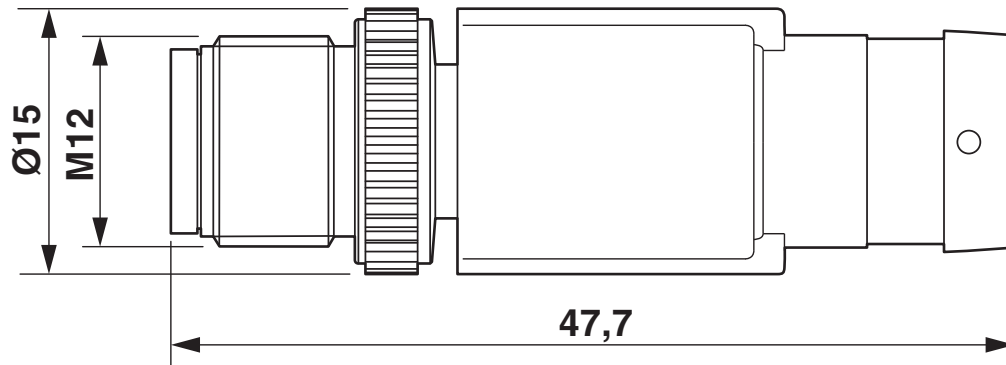

Plug, M12 x 1, straight, shielded

# SPE-T1-M12MS/ 2,0-99B/M12MS - Network cable



1364622

<https://www.phoenixcontact.com/de/produkte/1364622>

## Classifications

### ECLASS

ECLASS-11.0	27060307
ECLASS-12.0	27060307
ECLASS-13.0	27060307

### ETIM

ETIM 8.0	EC001855
----------	----------

Phoenix Contact 2023 © - all rights reserved

<https://www.phoenixcontact.com>

PHOENIX CONTACT Deutschland GmbH

Flachmarktstraße 8

D-32825 Blomberg

+49 52 35/3-1 20 00

[info@phoenixcontact.de](mailto:info@phoenixcontact.de)