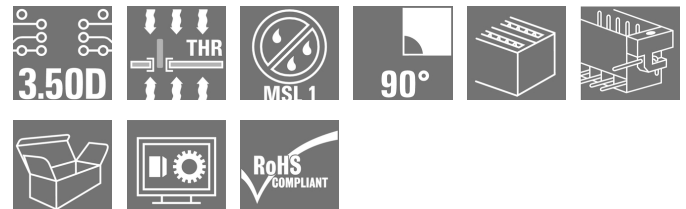

**OMNIMATE Signal - series B2C/S2C 3.50 - 2-row  
S2C-SMT 3.50/06/90LF 3.2SN BK BX**

**Weidmüller Interface GmbH & Co. KG**  
 Klingenbergstraße 26  
 D-32758 Detmold  
 Germany  
 Fon: +49 5231 14-0  
 Fax: +49 5231 14-292083  
 www.weidmueller.com

**Product image**

Similar to illustration

**High-temperature-resistant male header**

- Finger-safe
- Can be plugged into female plug B2CF 3.50 PUSH IN
- **Plug-in direction is perpendicular or parallel to the circuit board (180° / 90°)**
- Housing variants: closed (G) and with solder flange (LF)
- **Packed either in a box (BX) or on anti-static tape-on-reel (RL)**
- Suitable for reflow and wave soldering applications
- Pin length of either 1.5 mm or 3.2 mm

**General ordering data**

Type	S2C-SMT 3.50/06/90LF 3.2SN BK BX
Order No.	<a href="#">1289460000</a>
Version	PCB plug-in connector, male header, Solder flange, THT/THR solder connection, 3.50 mm, Number of poles: 6, 90°, Solder pin length (l): 3.2 mm, tinned, black, Box
GTIN (EAN)	4050118081817
Qty.	102 pc(s).
Product data	IEC: 200 V / 13.4 A UL: 150 V / 10 A
Packaging	Box

Creation date June 25, 2020 9:57:46 PM CEST

**OMNIMATE Signal - series B2C/S2C 3.50 - 2-row  
S2C-SMT 3.50/06/90LF 3.2SN BK BX**

**Weidmüller Interface GmbH & Co. KG**  
 Klingenbergstraße 26  
 D-32758 Detmold  
 Germany  
 Fon: +49 5231 14-0  
 Fax: +49 5231 14-292083  
 www.weidmueller.com

**Technical data****Dimensions and weights**

Width	14.1	Width (inches)	0.555 inch
Height	14 mm	Height (inches)	0.551 inch
Height of lowest version	10.8 mm	Depth	14.2 mm
Depth (inches)	0.559 inch	Net weight	3.735 g

**System specifications**

Product family	OMNIMATE Signal - series B2C/S2C 3.50 - 2-row	Type of connection	Board connection
Mounting onto the PCB	THT/THR solder connection	Pitch in mm (P)	3.5 mm
Pitch in inches (P)	0.138 inch	Outgoing elbow	90°
Number of poles	6	Number of solder pins per pole	1
Solder pin length (l)	3.2 mm	Tolerance of solder pin position	± 0.1 mm
Solder pin dimensions	d = 1.0 mm, Octagonal	Solder eyelet hole diameter (D)	1.3 mm
Solder eyelet hole diameter tolerance (D)+	0,1 mm	Outside diameter of solder pad	2.1 mm
Template aperture diameter	1.9 mm	L1 in mm	7 mm
L1 in inches	0.276 inch	Number of rows	1
Pin series quantity	2	Touch-safe protection acc. to DIN VDE 57 106	touch-safe on connector face, safe to back of hand above the printed circuit board
Touch-safe protection acc. to DIN VDE 0470	IP 20	Can be coded	Yes
Plugging cycles	25	Plugging force/pole, max.	3.5 N
Pulling force/pole, max.	2.5 N		

**Material data**

Insulating material	LCP GF	Colour	black
Colour chart (similar)	RAL 9011	Insulating material group	IIIb
Comparative Tracking Index (CTI)	≥ 175	Insulation strength	≥ 10 <sup>8</sup> Ω
Moisture Level (MSL)	1	UL 94 flammability rating	V-0
GWIT	930 °C	GWFI	960 °C
Contact material	Copper alloy	Contact surface	tinned
Layer structure of solder connection	1...3 µm Ni / 2...5 µm Sn matt	Layer structure of plug contact	2...5 µm Sn / 1...3 µm Ni
Storage temperature, min.	-25 °C	Storage temperature, max.	50 °C
Max. relative humidity during storage	70 %	Operating temperature, min.	-50 °C
Operating temperature, max.	120 °C	Temperature range, installation, min.	-40 °C
Temperature range, installation, max.	120 °C		

**Rated data acc. to IEC**

tested acc. to standard	IEC 60664-1, IEC 61984	Rated current, min. number of poles (Tu=20°C)	13.4 A
Rated current, min. number of poles (Tu=40°C)	12 A	Rated voltage for surge voltage class / pollution degree II/2	200 V
Rated voltage for surge voltage class / pollution degree III/2	160 V	Rated voltage for surge voltage class / pollution degree III/3	80 V
Rated impulse voltage for surge voltage class/ pollution degree II/2	2.5 kV	Rated impulse voltage for surge voltage class/ pollution degree III/2	2.5 kV
Rated impulse voltage for surge voltage class/ contamination degree III/3	2.5 kV	Short-time withstand current resistance	3 x 1s with 80 A

**OMNIMATE Signal - series B2C/S2C 3.50 - 2-row  
S2C-SMT 3.50/06/90LF 3.2SN BK BX**

**Weidmüller Interface GmbH & Co. KG**  
 Klingenbergstraße 26  
 D-32758 Detmold  
 Germany  
 Fon: +49 5231 14-0  
 Fax: +49 5231 14-292083  
 www.weidmueller.com

**Technical data****Rated data acc. to CSA**

Institute (CSA)



Certificate No. (CSA)

200039-1121690

Rated voltage (Use group B / CSA) 150 V

Rated voltage (Use group C / CSA) 50 V

Rated voltage (Use group D / CSA) 150 V

Rated current (Use group B / CSA) 9.5 A

Rated current (Use group C / CSA) 9.5 A

Rated current (Use group D / CSA) 9.5 A

Reference to approval values

Specifications are maximum values, details - see approval certificate.

**Rated data acc. to UL 1059**

Institute (cURus)



Certificate No. (cURus)

E60693

Rated voltage (Use group B / UL 1059) 150 V

Rated voltage (Use group C / UL 1059) 50 V

Rated current (Use group B / UL 1059) 10 A

Rated current (Use group C / UL 1059) 10 A

Reference to approval values

Specifications are maximum values, details - see approval certificate.

**Packing**

Packaging	Box	VPE length	35 mm
VPE width	135 mm	VPE height	350 mm

**Classifications**

ETIM 6.0	EC002637	ETIM 7.0	EC002637
eClass 9.0	27-44-04-02	eClass 9.1	27-44-04-02
eClass 10.0	27-44-04-02		

**Notes**

Notes

- Gold-plated contact surfaces on request
- Rated current related to rated cross-section & min. No. of poles.
- Spacing between rows: see hole layout
- P on drawing = pitch
- Rated data refer only to the component itself. Clearance and creepage distances to other components are to be designed in accordance with the relevant application standards.

IPC conformity

Conformity: The products are developed, manufactured and delivered according international recognized standards and norms and comply with the assured properties in the data sheet resp. fulfill decorative properties in accordance with IPC-A-610 "Class 2". Further claims on the products can be evaluated on request.

**Data sheet**

**OMNIMATE Signal - series B2C/S2C 3.50 - 2-row  
S2C-SMT 3.50/06/90LF 3.2SN BK BX**

**Weidmüller Interface GmbH & Co. KG**  
Klingenbergstraße 26  
D-32758 Detmold  
Germany  
Fon: +49 5231 14-0  
Fax: +49 5231 14-292083  
www.weidmueller.com

**Technical data**

**Approvals**

Approvals



ROHS

Conform

**Downloads**

Approval/Certificate/Document of  
Conformity

[Declaration of the Manufacturer](#)

Brochure/Catalogue

- [FL DRIVES EN](#)
- [MB SMT EN](#)
- [FL DRIVES DE](#)
- [MB DEVICE MANUF. EN](#)
- [CAT 2 PORTFOLIOGUIDE EN](#)
- [FL BUILDING SAFETY EN](#)
- [FL APPL LED LIGHTING EN](#)
- [FLIndustr.CONTROLS EN](#)
- [FL MACHINE SAFETY EN](#)
- [FL HEATING ELECTR EN](#)
- [FL APPL\\_INVERTER EN](#)
- [FL\\_BASE\\_STATION\\_EN](#)
- [FL ELEVATOR EN](#)
- [FL POWER SUPPLY EN](#)
- [FL 72H SAMPLE SER EN](#)
- [PO OMNIMATE EN](#)

Engineering Data

[EPLAN, WSCAD](#)

Engineering Data

[STEP](#)

White paper surface mount technology

[Download Whitepaper](#)

**Data sheet**

**OMNIMATE Signal - series B2C/S2C 3.50 - 2-row  
S2C-SMT 3.50/06/90LF 3.2SN BK BX**

**Weidmüller Interface GmbH & Co. KG**  
 Klingenbergstraße 26  
 D-32758 Detmold  
 Germany  
 Fon: +49 5231 14-0  
 Fax: +49 5231 14-292083  
 www.weidmueller.com

**Drawings**

**Dimensional drawing**

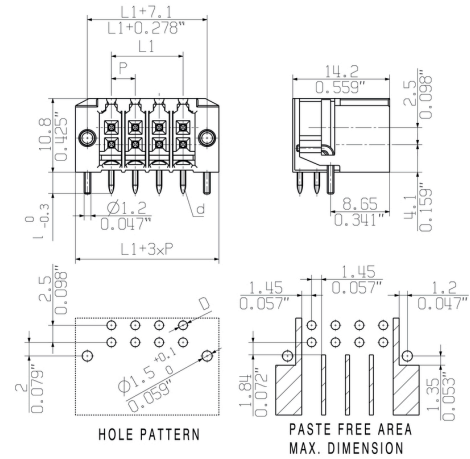

The reproduction, distribution and utilization of this document as well as the communication of its contents without explicit authorization is prohibited. Offenders will be held liable for the payment of damages. Weidmüller exclusively reserves the right to file for patents, utility models or designs.

© Weidmüller Interface GmbH & Co. KG

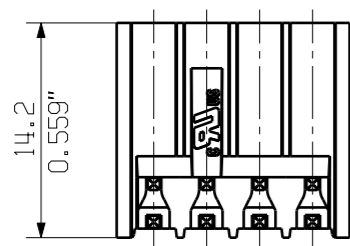

SHOWN: S2C-SMT 3.50/08/90G 3.2

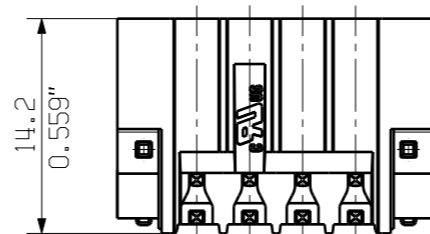

SHOWN: S2C-SMT 3.50/08/90LF 3.2

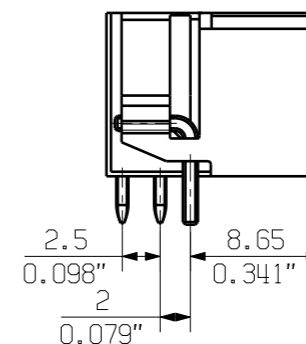
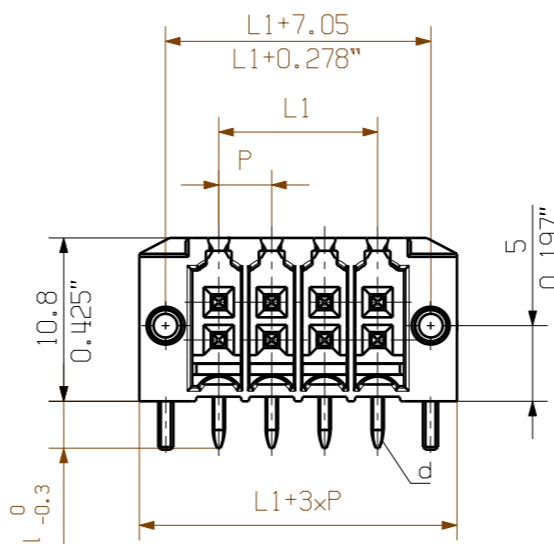
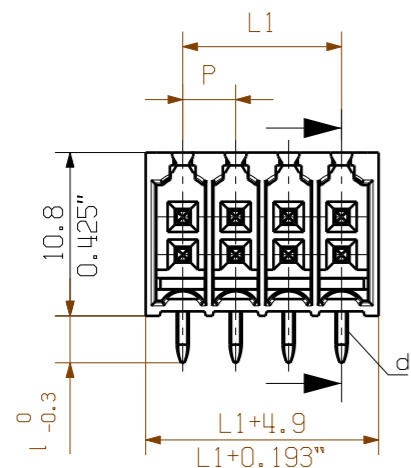

HOLE PATTERN

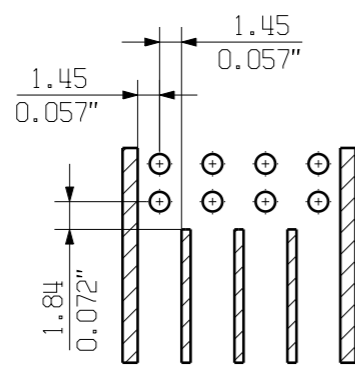

PASTE FREE AREA  
MAX. DIMENSION

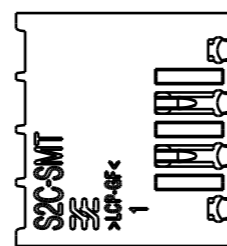

HOLE PATTERN

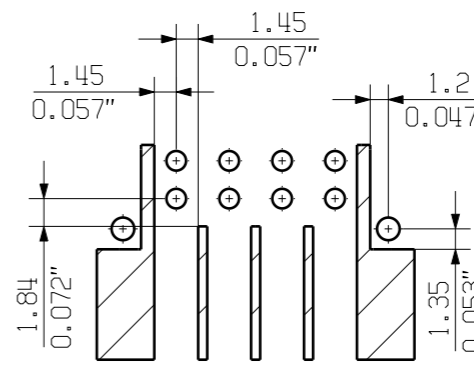

PASTE FREE AREA  
MAX. DIMENSION

M 1/1  
S2C-SMT 3.50/08/90G 1.5

M 1/1  
S2C-SMT 3.50/08/90G 3.2

M 1/1  
S2C-SMT 3.50/08/90LF 1.5

M 1/1  
S2C-SMT 3.50/08/90LF 3.2

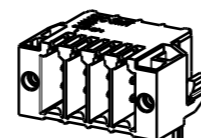
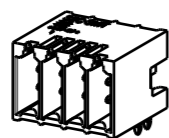
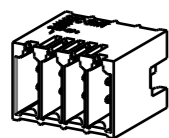

P = 3.50 RASTER PITCH

D\* = Ø1.3 +0.1 / 0.051"

d = 0.8x0.8 / 0.031"x0.031"

\* from n (no of poles) 26  
D = 1.4mm +0.1

S2C-SMT 3.50...180LF 3.5	3.5	0.126
S2C-SMT 3.50...180LF 1.5	1.5	0.059
S2C-SMT 3.50...180G 3.5	3.2	0.126
S2C-SMT 3.50...180G 1.5	1.5	0.059
TYP PART NAME	[mm]	[inch]

For the mounting of PCBs, it should be noted that the rated data relates only to the PCB components alone. The necessary creepage and clearance paths must be observed in connection with the respective applicant in accordance to IEC 664 / VDE 0110. The current-carrying capacity and pitch tolerance is to be determined according to DIN IEC 326 part 3 very fine.

Weidmüller PCB components are tested to the DIN EN 61984 standard, and are valid for its field of application. Provided that the components are used to the intended purpose, all requirements with respect to the occurring of electrical, mechanical, thermic and corrosive stress will be satisfied.

36	59.5	2.343	±0.2	
34	56.0	2.205		
32	52.5	2.067		
30	49.0	1.929		
28	45.5	1.791	±0.15	
26	42.0	1.654		
24	38.5	1.516		
22	35.0	1.378		
20	31.5	1.240	±0.1	
18	28.0	1.102		
16	24.5	0.965		
16	24.5	0.965		
14	21.0	0.827	±0.1	
12	17.5	0.689		
10	14.0	0.551		
8	10.5	0.413		
6	7.00	0.276	±0.1	
4	3.50	0.138		
n	POLZAHL POLES	L1 [mm]	L1 [inch]	TOLERANZ TOLERANCE

GENERAL TOLERANCE:  
DIN ISO 2768-m

Max. nos.



99681/4	01
22.03.18 AMANN_A	
Modification	
Drawn	15.07.2011 FRIELING_L
Responsible	AMANN_A
Checked	04.04.2018 HELIS_MA
Approved	LANG_T

**Weidmüller**

Cat.no.: .

**3 50160**

Drawing no. **3 50160** Issue no. **06**  
Sheet 02 of 04 sheets

**S2C-SMT 3.50/.../...**  
STIFTLISTE  
MALE HEADER

Product file: B2CF/S2C

7400

allgemeinguetliche Kundenzeichnung, aktueller Stand nur auf Anfrage  
general customer drawing, topical version only if required

## Recommended wave soldering profiles

**Weidmüller Interface GmbH & Co. KG**  
 Klingenbergstraße 16  
 D-32758 Detmold  
 Germany  
 Fon: +49 5231 14-0  
 Fax: +49 5231 14-292083  
 www.weidmueller.com

### Single Wave:



### Double Wave:



### Wave soldering profiles

Wired connection elements should be processed in accordance with the DIN EN 61760-1 standard. We have included two recommendations for practical wave soldering profiles, with which Weidmüller PCB terminals and connectors are qualified.

When choosing a suitable profile for your application, the following factors also need to be considered:

- PCB thickness
- Proportion of Cu in the layers
- Single/double-sided assembly
- Product range
- Heating and cooling rates

The single and double wave profiles each indicate the recommended operating range, including the maximum soldering temperature of 260°C. In practice, the maximum soldering temperature is quite often well below the above maximum profile.

## Recommended reflow soldering profile

**Weidmüller Interface GmbH & Co. KG**  
 Klingenbergstraße 16  
 D-32758 Detmold  
 Germany  
 Fon: +49 5231 14-0  
 Fax: +49 5231 14-292083  
 www.weidmueller.com



### Reflow soldering profile

The perfect soldering profile for SMT Surface Mount Technology is one the most exiting question in SMT production. But there are more than one correct answer: The diagram of temperature-on-time is related to processing features of solder paste and to maximum load of components.

We have to consider the following parameters:

- Time for pre heating
- Maximum temperature
- Time above melting point
- Time for cooling
- Maximum heating rate
- Maximum cooling rate

We recommend a typical solder profile with associated process limits. With preheating components and board are prepared smoothly for the solder phase. Heating rate is typically  $\leq +3\text{K/s}$ . In parallel the solder paste is ‚activated‘. The time above melting point of 217°C the paste gets liquid and components and boards begin to connect. The maximum temperature of 245°C to 254°C should stay between 10 and 40 seconds. In the cooling phase at  $\geq -6\text{K/s}$  solder is cured. Board and components cool down while avoiding cold cracks.