

## LU 10.16/10/90 4.5SN BK BX

**Weidmüller Interface GmbH & Co. KG**  
 Klingenbergstraße 26  
 D-32758 Detmold  
 Germany

www.weidmueller.com

### Product image

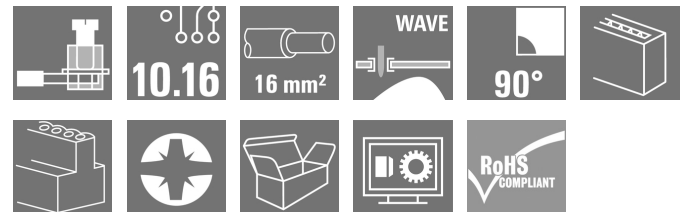

This PCB terminal provides connections for 76 A and 16 mm<sup>2</sup> conductor cross-section with proven clamping yoke connection at 10.16 mm pitch, conductor outlet direction in 90° design.

### General ordering data

Version	Printed circuit board terminals, 10.16 mm, Number of poles: 10, 90°, Solder pin length (l): 4.5 mm, tinned, black, Clamping yoke connection, Clamping range, max. : 16 mm <sup>2</sup> , Box
Order No.	<a href="#">1226280000</a>
Type	LU 10.16/10/90 4.5SN BK BX
GTIN (EAN)	4050118010824
Qty.	20 pc(s).
Product data	IEC: 1000 V / 76 A / 0.5 - 16 mm <sup>2</sup> UL: 300 V / 65 A / AWG 26 - AWG 6
Packaging	Box

Creation date December 4, 2023 2:21:56 PM CET

## LU 10.16/10/90 4.5SN BK BX

**Weidmüller Interface GmbH & Co. KG**

Klingenbergstraße 26

D-32758 Detmold

Germany

www.weidmueller.com

## Technical data

### Dimensions and weights

Depth	18.3 mm	Depth (inches)	0.72 inch
Height	33 mm	Height (inches)	1.299 inch
Height of lowest version	28.5 mm	Width	101.6 mm
Width (inches)	4 inch	Net weight	93.85 g

### System parameters

Product family	OMNIMATE Power - series LU	Wire connection method	Clamping yoke connection
Mounting onto the PCB	THT solder connection	Conductor outlet direction	90°
Pitch in mm (P)	10.16 mm	Pitch in inches (P)	0.4 inch
Number of poles	10	Pin series quantity	1
Fitted by customer	Yes	Number of rows	1
Max. adjacent poles per row	10	Solder pin length (l)	4.5 mm
Solder pin dimensions	1.2 x 1.2 mm	Solder pin dimensions = d tolerance	0 / -0,15 mm
Solder eyelet hole diameter (D)	1.6 mm	Solder eyelet hole diameter tolerance (D)+	0,1 mm
Number of solder pins per pole	2	Screwdriver blade	1.0 x 5.5
Screwdriver blade standard	DIN 5264	Tightening torque, min.	1.2 Nm
Tightening torque, max.	2.2 Nm	Clamping screw	M 4
Stripping length	12 mm	L1 in mm	91.44 mm
L1 in inches	3.6 inch	Touch-safe protection acc. to DIN VDE 0470	IP20 plugged/ IP10 unplugged
Touch-safe protection acc. to DIN VDE 57 106	Safe from finger touch	Protection degree	IP20
Volume resistance	0.50 mΩ		

### Material data

Insulating material	Wemid (PA)	Colour	black
Colour chart (similar)	RAL 9011	Insulating material group	I
Comparative Tracking Index (CTI)	≥ 600	UL 94 flammability rating	V-0
Contact material	E-Cu	Contact surface	tinned
Layer structure of solder connection	1.5...3 μm Ni / 4...6 μm Sn matt	Storage temperature, min.	-40 °C
Storage temperature, max.	70 °C	Operating temperature, min.	-50 °C
Operating temperature, max.	120 °C	Temperature range, installation, min.	-25 °C
Temperature range, installation, max.	120 °C		

### Conductors suitable for connection

Clamping range, min.	0.14 mm <sup>2</sup>
Clamping range, max.	16 mm <sup>2</sup>
Wire connection cross section AWG, min.	AWG 22
Wire connection cross section AWG, max.	AWG 8
Solid, min. H05(07) V-U	0.5 mm <sup>2</sup>
Solid, max. H05(07) V-U	16 mm <sup>2</sup>
Stranded, min. H07V-R	6 mm <sup>2</sup>
Stranded, max. H07V-R	16 mm <sup>2</sup>
Flexible, min. H05(07) V-K	0.5 mm <sup>2</sup>
Flexible, max. H05(07) V-K	16 mm <sup>2</sup>
w. plastic collar ferrule, DIN 46228 pt 4, min.	2.5 mm <sup>2</sup>
w. plastic collar ferrule, DIN 46228 pt 4, max.	10 mm <sup>2</sup>

Creation date December 4, 2023 2:21:56 PM CET

Catalogue status 24.11.2023 / We reserve the right to make technical changes.

## LU 10.16/10/90 4.5SN BK BX

**Weidmüller Interface GmbH & Co. KG**  
 Klingenbergstraße 26  
 D-32758 Detmold  
 Germany

www.weidmueller.com

## Technical data

w. wire end ferrule, DIN 46228 pt 1, min.	2.5 mm <sup>2</sup>			
w. wire end ferrule, DIN 46228 pt 1, max.	10 mm <sup>2</sup>			
Plug gauge in accordance with EN 60999 a x b; ø	5.4 mm x 5.1 mm; 5.3 mm			
Clampable conductor	Cross-section for conductor connection	Type	fine-wired	
		nominal	2.5 mm <sup>2</sup>	
	wire end ferrule	Stripping length	nominal	12 mm
		Recommended wire-end ferrule	<a href="#">H2.5/12</a>	
		Stripping length	nominal	14 mm
		Recommended wire-end ferrule	<a href="#">H2.5/19D BL</a>	
	Cross-section for conductor connection	Type	fine-wired	
		nominal	4 mm <sup>2</sup>	
	wire end ferrule	Stripping length	nominal	12 mm
		Recommended wire-end ferrule	<a href="#">H4.0/12</a>	
		Stripping length	nominal	14 mm
		Recommended wire-end ferrule	<a href="#">H4.0/20D GR</a>	
	Cross-section for conductor connection	Type	fine-wired	
		nominal	6 mm <sup>2</sup>	
	wire end ferrule	Stripping length	nominal	12 mm
		Recommended wire-end ferrule	<a href="#">H6.0/12</a>	
		Stripping length	nominal	14 mm
		Recommended wire-end ferrule	<a href="#">H6.0/20 SW</a>	
	Cross-section for conductor connection	Type	fine-wired	
		nominal	10 mm <sup>2</sup>	
wire end ferrule	Stripping length	nominal	15 mm	
	Recommended wire-end ferrule	<a href="#">H10.0/22 EB</a>		
	Stripping length	nominal	12 mm	
	Recommended wire-end ferrule	<a href="#">H10.0/12</a>		

Reference text Length of ferrules is to be chosen depending on the product and the rated voltage.. The outside diameter of the plastic collar should not be larger than the pitch (P)

### Rated data acc. to IEC

tested acc. to standard	IEC 60664-1, IEC 61984	Rated current, min. number of poles (Tu=20°C)	76 A
Rated current, max. number of poles (Tu=20°C)	72 A	Rated current, min. number of poles (Tu=40°C)	76 A
Rated current, max. number of poles (Tu=40°C)	62 A	Rated voltage for surge voltage class / pollution degree II/2	1,000 V
Rated voltage for surge voltage class / pollution degree III/2	690 V	Rated voltage for surge voltage class / pollution degree III/3	690 V
Rated impulse voltage for surge voltage class/ pollution degree II/2	4 kV	Rated impulse voltage for surge voltage class/ pollution degree III/2	6 kV
Rated impulse voltage for surge voltage class/ contamination degree III/3	6 kV	Short-time withstand current resistance	2 x 1s with 700 A

**LU 10.16/10/90 4.5SN BK BX**
**Weidmüller Interface GmbH & Co. KG**

 Klingenbergstraße 26  
 D-32758 Detmold  
 Germany

[www.weidmueller.com](http://www.weidmueller.com)
**Technical data**
**Rated data acc. to CSA**

Institute (CSA)



Certificate No. (CSA)

200039-1198743

Rated voltage (Use group B / CSA)	300 V
Rated voltage (Use group D / CSA)	300 V
Rated current (Use group C / CSA)	65 A
Wire cross-section, AWG, min.	AWG 22
Reference to approval values	Specifications are maximum values, details - see approval certificate.

Rated voltage (Use group C / CSA)	150 V
Rated current (Use group B / CSA)	65 A
Rated current (Use group D / CSA)	10 A
Wire cross-section, AWG, max.	AWG 6

**Rated data acc. to UL 1059**

Institute (UR)



Certificate No. (UR)

E60693

Rated voltage (Use group B / UL 1059)	300 V
Rated voltage (Use group D / UL 1059)	600 V
Rated current (Use group C / UL 1059)	65 A
Wire cross-section, AWG, min.	AWG 26
Reference to approval values	Specifications are maximum values, details - see approval certificate.

Rated voltage (Use group C / UL 1059)	150 V
Rated current (Use group B / UL 1059)	65 A
Rated current (Use group D / UL 1059)	5 A
Wire cross-section, AWG, max.	AWG 6

**Packing**

Packaging	Box	VPE length	165 mm
VPE width	147 mm	VPE height	74 mm

**Type tests**

Test: Durability of markings	Test	mark of origin, type identification, type of material, rated cross-section, approval marking CSA, approval marking UL, pitch, durability
	Evaluation	available

**LU 10.16/10/90 4.5SN BK BX**

**Weidmüller Interface GmbH & Co. KG**  
 Klingenbergstraße 26  
 D-32758 Detmold  
 Germany

www.weidmueller.com

**Technical data**

Test: Clampable cross section	Conductor type	Type of conductor and conductor cross-section	H05V-K0.5
		Type of conductor and conductor cross-section	H05V-U0.5
		Type of conductor and conductor cross-section	H07V-K10
		Type of conductor and conductor cross-section	H07V-U10
		Type of conductor and conductor cross-section	H07V-U16
		Type of conductor and conductor cross-section	AWG 8/19
		Type of conductor and conductor cross-section	AWG 22/1
		Type of conductor and conductor cross-section	AWG 22/19
	Evaluation	passed	
Test for damage to and accidental loosening of conductors	Standard	EN 60947-1/1991 section 8.2.4.3	
	Requirement	0.3 kg	
	Conductor type	Type of conductor and conductor cross-section	H05V-K0.5
		Type of conductor and conductor cross-section	H05V-U0.5
		Type of conductor and conductor cross-section	AWG 22/1
		Type of conductor and conductor cross-section	AWG 22/19
	Evaluation	passed	
	Requirement	2.0 kg	
	Conductor type	Type of conductor and conductor cross-section	H07V-K10
		Type of conductor and conductor cross-section	H07V-U10
		Type of conductor and conductor cross-section	AWG 8/19
	Evaluation	passed	
Requirement	2.9 kg		
Conductor type	Type of conductor and conductor cross-section	H07V-U16	
Evaluation	passed		

**LU 10.16/10/90 4.5SN BK BX**

**Weidmüller Interface GmbH & Co. KG**  
 Klingenbergstraße 26  
 D-32758 Detmold  
 Germany

www.weidmueller.com

**Technical data**

Pull-out test	Standard	EN 60947-1/1991 section 8.2.4.4		
	Requirement	≥20 N		
	Conductor type	Type of conductor and conductor cross-section	AWG 22/1	
		Type of conductor and conductor cross-section	AWG 22/19	
	Evaluation	passed		
	Requirement	≥30 N		
	Conductor type	Type of conductor and conductor cross-section	H05V-K0.5	
		Type of conductor and conductor cross-section	H05V-U0.5	
	Evaluation	passed		
	Requirement	≥ 90N		
	Conductor type	Type of conductor and conductor cross-section	H07V-K10	
		Type of conductor and conductor cross-section	H07V-U10	
		Type of conductor and conductor cross-section	AWG 8/19	
	Evaluation	passed		
	Requirement	≥100 N		
Conductor type	Type of conductor and conductor cross-section	H07V-U16		
Evaluation	passed			

**Classifications**

ETIM 6.0	EC002643	ETIM 7.0	EC002643
ETIM 8.0	EC002643	ETIM 9.0	EC002643
ECLASS 9.0	27-44-04-01	ECLASS 9.1	27-44-04-01
ECLASS 10.0	27-44-04-01	ECLASS 11.0	27-46-01-01
ECLASS 12.0	27-46-01-01	ECLASS 13.0	27460101

## LU 10.16/10/90 4.5SN BK BX

**Weidmüller Interface GmbH & Co. KG**  
Klingenbergstraße 26  
D-32758 Detmold  
Germany

www.weidmueller.com

## Technical data

### Important note

IPC conformity	Conformity: The products are developed, manufactured and delivered according international recognized standards and norms and comply with the assured properties in the data sheet resp. fulfill decorative properties in accordance with IPC-A-610 "Class 2". Further claims on the products can be evaluated on request.
Notes	<ul style="list-style-type: none"> <li>• Additional variants on request</li> <li>• Rated current related to rated cross-section &amp; min. No. of poles.</li> <li>• Wire end ferrule without plastic collar to DIN 46228/1</li> <li>• Wire end ferrule with plastic collar to DIN 46228/4</li> <li>• P on drawing = pitch</li> <li>• Rated data refer only to the component itself. Clearance and creepage distances to other components are to be designed in accordance with the relevant application standards.</li> <li>• Long term storage of the product with average temperature of 50 °C and maximum humidity 70%, 36 months</li> </ul>

### Approvals

Approvals



ROHS	Conform
UL File Number Search	UL Website
Certificate No. (UR)	E60693

### Downloads

Approval/Certificate/Document of Conformity	<a href="#">Declaration of the Manufacturer</a>
Engineering Data	<a href="#">CAD data – STEP</a>
Product Change Notification	<a href="#">20220201 Visual change OMNIMATE® Power PCB terminal blocks and connectors</a> <a href="#">20220201 Visuelle Änderung OMNIMATE® Power Leiterplattenklemmen und -steckverbinder</a>
User Documentation	<a href="#">QR-Code product handling video</a>
Catalogues	<a href="#">Catalogues in PDF-format</a>
Brochures	<a href="#">FL DRIVES EN</a> <a href="#">MB DEVICE MANUF. EN</a> <a href="#">FL DRIVES DE</a> <a href="#">FL APPL_INVERTER EN</a> <a href="#">FL_BASE_STATION_EN</a> <a href="#">FL ELEVATOR EN</a> <a href="#">FL POWER SUPPLY EN</a> <a href="#">FL 72H SAMPLE SER EN</a> <a href="#">PO OMNIMATE EN</a> <a href="#">PO OMNIMATE EN</a>

**Data sheet**

**LU 10.16/10/90 4.5SN BK BX**

**Weidmüller Interface GmbH & Co. KG**  
 Klingenbergstraße 26  
 D-32758 Detmold  
 Germany

www.weidmueller.com

**Drawings**

**Product image**

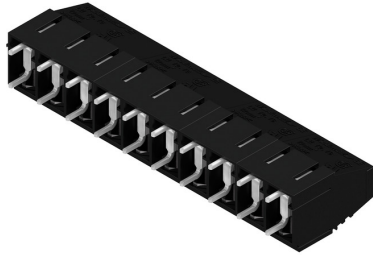

**Dimensional drawing**

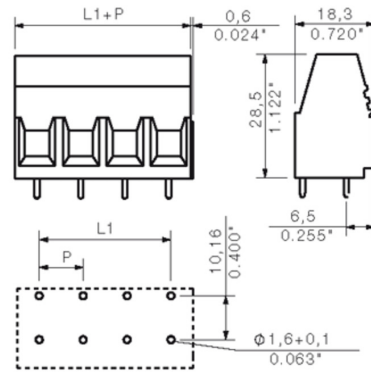

**Graph**

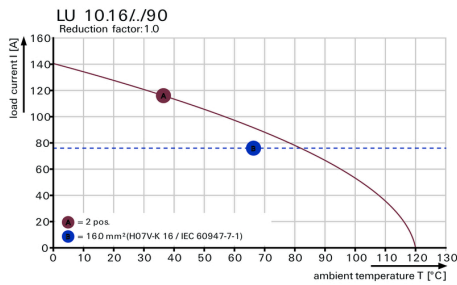

## LU 10.16/10/90 4.5SN BK BX

**Weidmüller Interface GmbH & Co. KG**  
Klingenbergstraße 26  
D-32758 Detmold  
Germany

[www.weidmueller.com](http://www.weidmueller.com)

## Accessories

## Slotted screwdriver

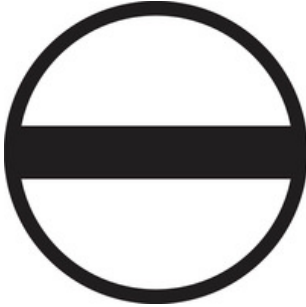

Slotted screwdriver with rounded blade SD DIN 5265, ISO 2380/2, output to DIN 5264, ISO 2380/1. ChromTop tip, SoftFinish grip

## General ordering data

Type	SDS 1.0X5.5X150	Version
Order No.	<a href="#">9008350000</a>	Screwdriver, Screwdriver
GTIN (EAN)	4032248056316	
Qty.	1 pc(s).	

## Crosshead screwdriver Pozidriv



Crosshead screwdriver, Pozidriv, SDK PZ DIN 5262, ISO 8764/2-PZ, output to ISO 8764/1-PZ, ChromTop tip, SoftFinish grip

## General ordering data

Type	SDK PZ2	Version
Order No.	<a href="#">9008540000</a>	Screwdriver, Screwdriver
GTIN (EAN)	4032248056538	
Qty.	1 pc(s).	

## LU 10.16/10/90 4.5SN BK BX

**Weidmüller Interface GmbH & Co. KG**  
 Klingenbergstraße 26  
 D-32758 Detmold  
 Germany

[www.weidmueller.com](http://www.weidmueller.com)

## Accessories

## Crosshead screwdriver Pozidriv



VDE insulated crosshead screwdriver type Pozidriv SDIK PZ DIN 7438, ISO 8764/2-PZ, output to ISO 8764-PZ, SoftFinish grip

## General ordering data

Type	SDIK PZ2	Version
Order No.	<a href="#">9008890000</a>	Screwdriver, Screwdriver
GTIN (EAN)	4032248266661	
Qty.	1 pc(s).	

## Slotted screwdriver

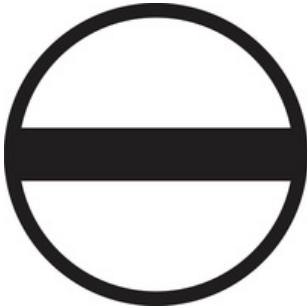

VDE insulated slot-head screwdriver, SDI DIN 7437, ISO 2380/2, drive output acc. to DIN 5264, ISO 2380/1. SoftFinish grip

## General ordering data

Type	SDIS 1.0X5.5X125	Version
Order No.	<a href="#">9008410000</a>	Screwdriver, Screwdriver
GTIN (EAN)	4032248056378	
Qty.	1 pc(s).	

The reproduction, distribution and utilization of this document as well as the communication of its contents to others without explicit authorization is prohibited. Offenders will be held liable for the payment of damages. Weidmüller exclusively reserves the right to file for patents, utility models or designs.

© Weidmüller Interface GmbH & Co. KG

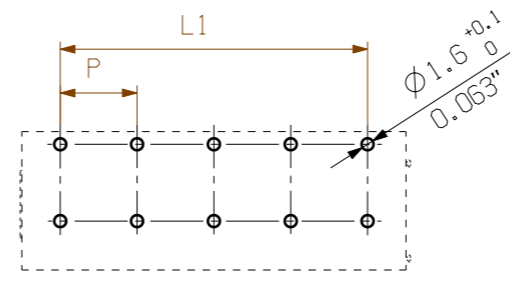
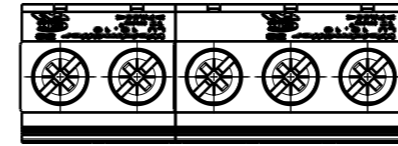
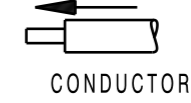
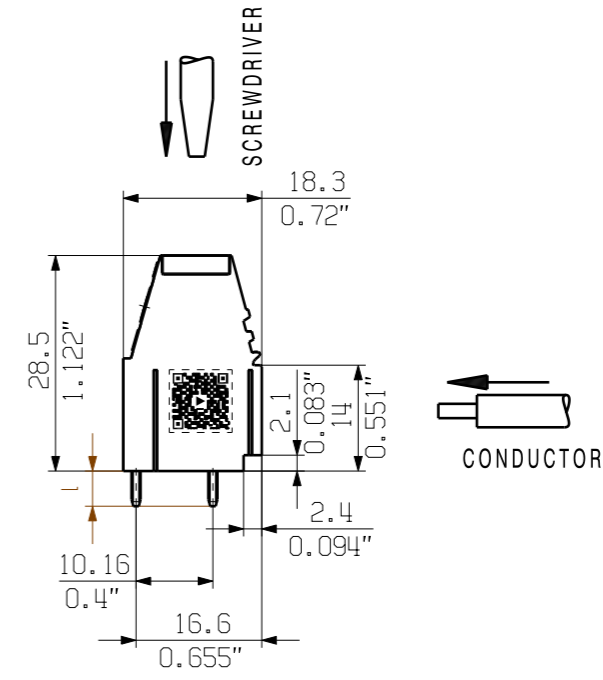
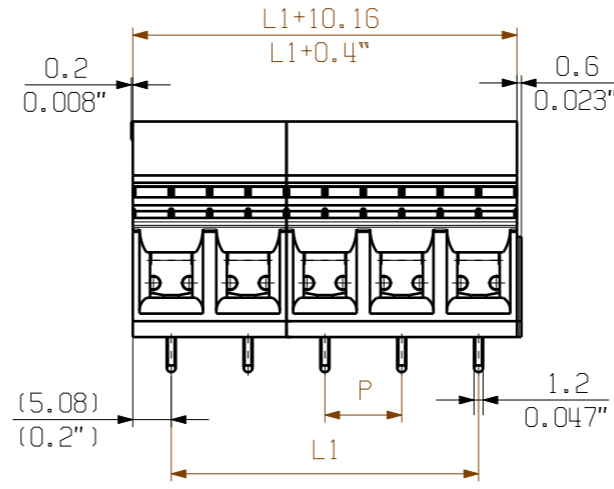

HOLE PATTERN

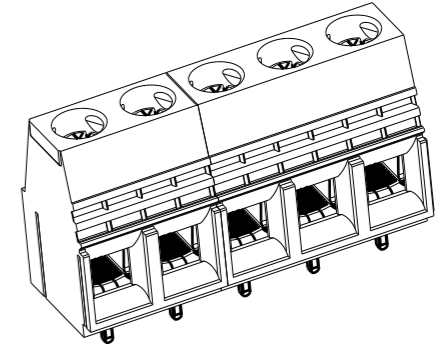

12	111,76	4,400
11	101,60	4,000
10	91,44	3,600
9	81,28	3,200
8	71,12	2,800
7	60,96	2,400
6	50,80	2,000
5	40,64	1,600
4	30,48	1,200
3	20,32	0,800
2	10,16	0,400
<b>n</b>	<b>L1 [mm]</b>	<b>L1 [inch]</b>

l = Lötstiftlänge  
solder pin length (4.5/3.2)  
P = Raster/pitch  
n = Polzahl/no of poles

SHOWN: LU10.16/05/90 2STI

For the mounting of PCBs, it should be noted that the rated data relates only to the PCB components alone. The necessary creepage and clearance paths must be observed in connection with the respective applicant in accordance to IEC 664 / VDE 0110. The current-carrying capacity and pitch tolerance is to be determined according to DIN IEC 326 part 3 very fine.

Weidmüller PCB components are tested to the DIN EN 61984 standard, and are valid for its field of application. Provided that the components are used to the intended purpose, all requirements with respect to the occurring of electrical, mechanical, thermic and corrosive stress will be satisfied.

<b>GENERAL TOLERANCE:</b> DIN ISO 2768-mK		Prim PLM Part No.: 027097		Prim ERP Part No.: 1934140000	
102098		04			
First Issue Date 16.02.2018		Modification			
		Date		Name	
Scale: 2:1		16.02.2018		Administrator	
Size: A3		Responsible		Amann, Alexand	
Drawings Assembly		Approved		12.11.2018 Lang, Thomas	
LU10.16/.. /90... LEITERPLATTENKLEMME PCB TERMINAL				Drawing no. <b>21382</b> Issue no. <b>21</b>	
				Sheet 01 of 01 sheets	
Product file: 7232 LU 10.16					

## Recommended wave soldering profiles

**Weidmüller Interface GmbH & Co. KG**  
 Klängenbergstraße 16  
 D-32758 Detmold  
 Germany  
 Fon: +49 5231 14-0  
 Fax: +49 5231 14-292083  
 www.weidmueller.com

### Single Wave:

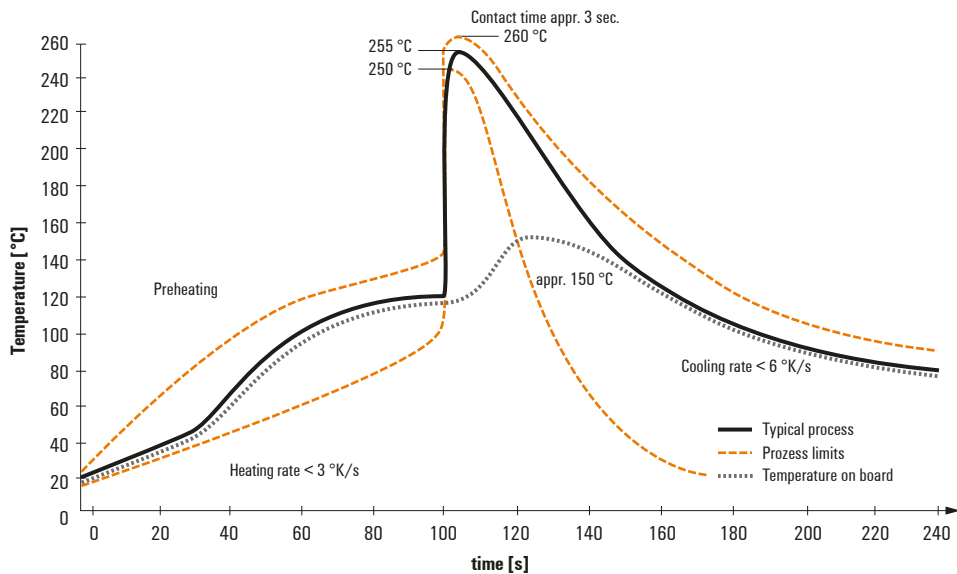

### Double Wave:

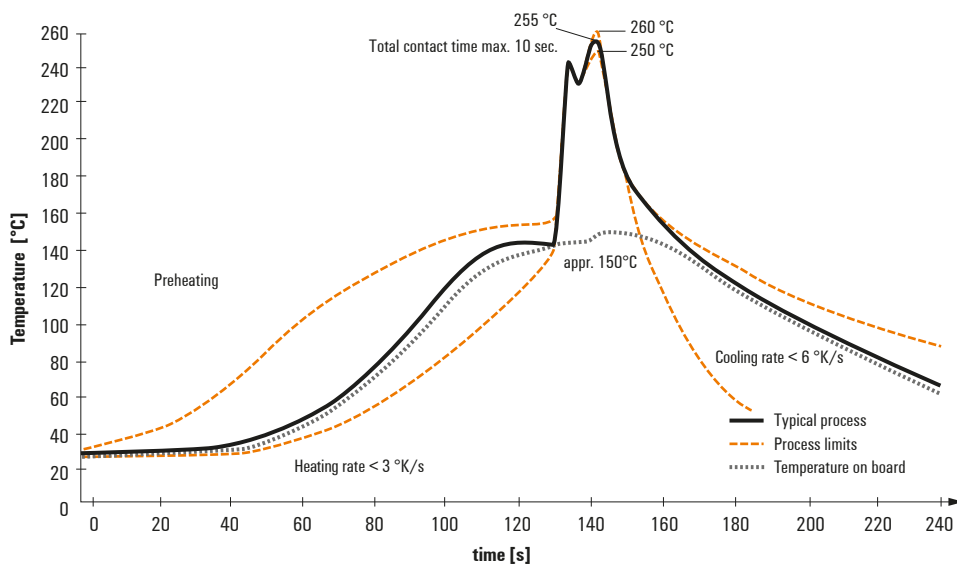

### Wave soldering profiles

Wired connection elements should be processed in accordance with the DIN EN 61760-1 standard. We have included two recommendations for practical wave soldering profiles, with which Weidmüller PCB terminals and connectors are qualified.

When choosing a suitable profile for your application, the following factors also need to be considered:

- PCB thickness
- Proportion of Cu in the layers
- Single/double-sided assembly
- Product range
- Heating and cooling rates

The single and double wave profiles each indicate the recommended operating range, including the maximum soldering temperature of 260°C. In practice, the maximum soldering temperature is quite often well below the above maximum profile.