

## SL 7.62IT/04/90MF2 3.2SN BK BX

**Weidmüller Interface GmbH & Co. KG**

Klingenbergstraße 26

D-32758 Detmold

Germany

[www.weidmueller.com](http://www.weidmueller.com)

### Product image

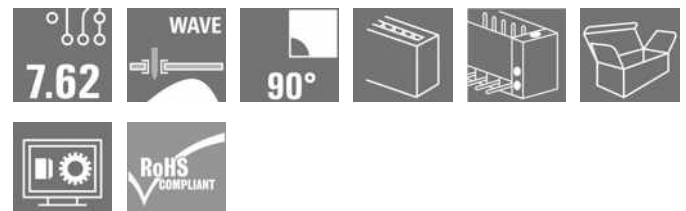

90° male header with soldered flange fastening with 7.62 pitch for 400 V IT power networks according to IEC 61800-5-1. UL approval as per UL840 600 V with leading PE contact.

Meets the increased requirements on touch safety for IT power networks as per IEC 61800-5-1 for 400 V to earth, when combined with female header BLZ 7.62 IT...

Without a female header, the mating profile guarantees minimum touch safety of 1 mm with 20 N pressure on the test finger. The interlock in the middle flange reduces the space requirements in comparison with conventional solutions by one pitch width. On request: available with screw flange or without flange.

### General ordering data

Version	PCB plug-in connector, male header, closed side, Middle flange, THT solder connection, 7.62 mm, Number of poles: 4, 90°, Solder pin length (l): 3.2 mm, tinned, black, Box
Order No.	<a href="#">1173730000</a>
Type	SL 7.62IT/04/90MF2 3.2SN BK BX
GTIN (EAN)	4032248966295
Qty.	48 pc(s).
Product data	IEC: 630 V / 29 A UL: 300 V / 20 A
Packaging	Box

Creation date August 31, 2023 12:30:34 PM CEST

## SL 7.62IT/04/90MF2 3.2SN BK BX

Weidmüller Interface GmbH &amp; Co. KG

Klingenbergstraße 26

D-32758 Detmold

Germany

www.weidmueller.com

## Technical data

## Dimensions and weights

Depth	12.65 mm	Depth (inches)	0.498 inch
Height	11.6 mm	Height (inches)	0.457 inch
Height of lowest version	8.4 mm	Width	37.48 mm
Width (inches)	1.476 inch	Net weight	3.133 g

## Temperatures

Operating temperature, min.	-50 °C	Operating temperature, max.	100 °C
-----------------------------	--------	-----------------------------	--------

## System specifications

Product family	OMNIMATE Power - series BL/SL 7.62IT	Type of connection	Board connection
Mounting onto the PCB	THT solder connection	Pitch in mm (P)	7.62 mm
Pitch in inches (P)	0.3 inch	Outgoing elbow	90°
Number of poles	4	Number of solder pins per pole	1
Solder pin length (l)	3.2 mm	Solder pin dimensions	1.0 x 1.0 mm
Solder pin dimensions = d tolerance	+0,01 / -0,03 mm	Solder eyelet hole diameter (D)	1.4 mm
Solder eyelet hole diameter tolerance (D)	+ 0,1 mm	L1 in mm	30.48 mm
L1 in inches	1.2 inch	Number of rows	1
Pin series quantity	1	Touch-safe protection acc. to DIN VDE 57 106	Safe from finger touch, plugged
Touch-safe protection acc. to DIN VDE 0470	IP20 plugged	Protection degree	IP20 in installed state
Can be coded	Yes	Plugging cycles	25

## Material data

Insulating material	PBT GF	Colour	black
Colour chart (similar)	RAL 9011	Insulating material group	IIIa
Comparative Tracking Index (CTI)	≥ 200	UL 94 flammability rating	V-0
Contact material	Copper alloy	Contact surface	tinned
Layer structure of solder connection	2...3 µm Ni / 2...4 µm Sn matt	Layer structure of plug contact	1...3 µm Ni / 2...4 µm Sn matt
Storage temperature, min.	-40 °C	Storage temperature, max.	70 °C
Operating temperature, min.	-50 °C	Operating temperature, max.	100 °C
Temperature range, installation, min.	-25 °C	Temperature range, installation, max.	100 °C

## Rated data acc. to IEC

tested acc. to standard	IEC 60664-1, IEC 61984	Rated current, min. number of poles (Tu=20°C)	29 A
Rated current, max. number of poles (Tu=20°C)	26 A	Rated current, min. number of poles (Tu=40°C)	25 A
Rated current, max. number of poles (Tu=40°C)	21 A	Rated voltage for surge voltage class / pollution degree II/2	630 V
Rated voltage for surge voltage class / pollution degree III/2	500 V	Rated voltage for surge voltage class / pollution degree III/3	400 V
Rated impulse voltage for surge voltage class/ pollution degree II/2	6 kV	Rated impulse voltage for surge voltage class/ pollution degree III/2	6 kV
Rated impulse voltage for surge voltage class/ contamination degree III/3	6 kV	Short-time withstand current resistance	3 x 1s with 180 A
Clearance, min.	6.5 mm	Creepage distance, min.	8.1 mm

**SL 7.62IT/04/90MF2 3.2SN BK BX**
**Weidmüller Interface GmbH & Co. KG**

Klingenbergstraße 26

D-32758 Detmold

Germany

www.weidmueller.com

**Technical data**
**Rated data acc. to CSA**

Institute (CSA)



Certificate No. (CSA)

200039-1121690

Rated voltage (Use group B / CSA) 300 V

Rated voltage (Use group C / CSA) 300 V

Rated voltage (Use group D / CSA) 600 V

Rated current (Use group B / CSA) 20 A

Rated current (Use group C / CSA) 20 A

Rated current (Use group D / CSA) 5 A

Reference to approval values

Specifications are maximum values, details - see approval certificate.

**Rated data acc. to UL 1059**

Institute (cURus)



Certificate No. (cURus)

E60693

Rated voltage (Use group B / UL 1059) 300 V

Rated voltage (Use group C / UL 1059) 300 V

Rated voltage (Use group D / UL 1059) 600 V

Rated current (Use group B / UL 1059) 20 A

Rated current (Use group C / UL 1059) 20 A

Rated current (Use group D / UL 1059) 5 A

Clearance distance, min. 6.5 mm

Creepage distance, min. 11.2 mm

Reference to approval values

Specifications are maximum values, details - see approval certificate.

**Packing**

Packaging	Box	VPE length	344 mm
VPE width	135 mm	VPE height	24 mm

**Classifications**

ETIM 6.0	EC002637	ETIM 7.0	EC002637
ETIM 8.0	EC002637	ECLASS 9.0	27-44-04-02
ECLASS 9.1	27-44-04-02	ECLASS 10.0	27-44-04-02
ECLASS 11.0	27-46-02-01	ECLASS 12.0	27-46-02-01

**SL 7.62IT/04/90MF2 3.2SN BK BX**

**Weidmüller Interface GmbH & Co. KG**  
 Klingenbergstraße 26  
 D-32758 Detmold  
 Germany

www.weidmueller.com

**Technical data**
**Important note**

IPC conformity	Conformity: The products are developed, manufactured and delivered according international recognized standards and norms and comply with the assured properties in the data sheet resp. fulfill decorative properties in accordance with IPC-A-610 "Class 2". Further claims on the products can be evaluated on request.
Notes	<ul style="list-style-type: none"> <li>• Additional variants on request</li> <li>• Gold-plated contact surfaces on request</li> <li>• Rated current related to rated cross-section &amp; min. No. of poles.</li> <li>• P on drawing = pitch</li> <li>• Rated data refer only to the component itself. Clearance and creepage distances to other components are to be designed in accordance with the relevant application standards.</li> <li>• MFX and MSFX: X= Position of the middle flange e.g. MF2, MSF3</li> <li>• Long term storage of the product with average temperature of 50 °C and average humidity 70%, 36 months</li> </ul>

**Approvals**

Approvals



ROHS	Conform
UL File Number Search	UL Website
Certificate No. (cURus)	E60693

**Downloads**

Approval/Certificate/Document of Conformity	<a href="#">Declaration of the Manufacturer</a>
Engineering Data	<a href="#">CAD data – STEP</a>
Product Change Notification	<a href="#">DE - Change of packaging</a> <a href="#">EN - Change of packaging</a> <a href="#">DE - Change of packaging Step 2</a> <a href="#">EN - Change of packaging Step 2</a>
Catalogues	<a href="#">Catalogues in PDF-format</a>
Brochures	<a href="#">FL DRIVES EN</a> <a href="#">MB DEVICE MANUF. EN</a> <a href="#">FL DRIVES DE</a> <a href="#">FL HEATING ELECTR EN</a> <a href="#">FL APPL INVERTER EN</a> <a href="#">FL_BASE_STATION_EN</a> <a href="#">FL ELEVATOR EN</a> <a href="#">FL POWER SUPPLY EN</a> <a href="#">FL 72H SAMPLE SER EN</a> <a href="#">PO OMNIMATE EN</a> <a href="#">PO OMNIMATE EN</a>

Creation date August 31, 2023 12:30:34 PM CEST

Catalogue status 18.08.2023 / We reserve the right to make technical changes.

**Data sheet**

**SL 7.62IT/04/90MF2 3.2SN BK BX**

**Weidmüller Interface GmbH & Co. KG**  
 Klingenbergstraße 26  
 D-32758 Detmold  
 Germany

www.weidmueller.com

**Drawings**

**Product image**

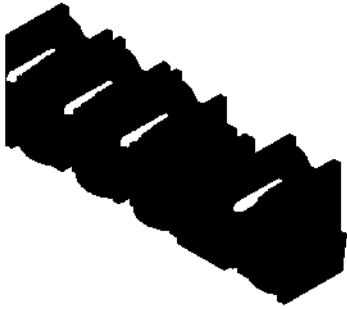

**Dimensional drawing**

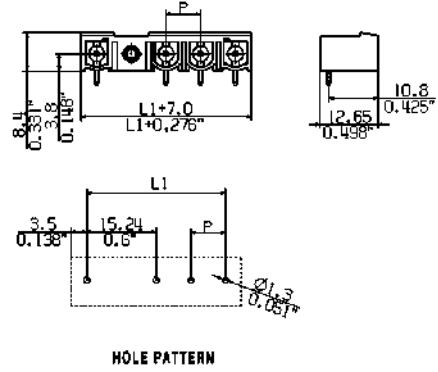

**Dimensional drawing**

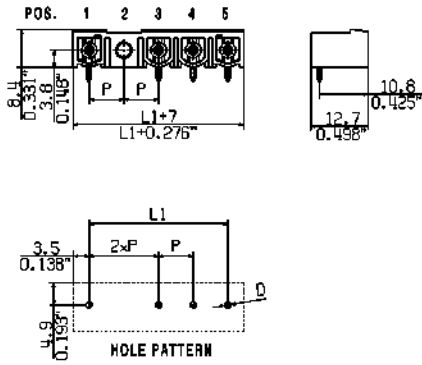

MASSE OHNE TOLERANZ SIND KEINE PRUEFMASSE  
 DIMS. WITHOUT TOLERANCE ARE NOT CONTROL DIMS.

DIE DEUTSCHE VERSION IST VERBINDLICH  
 THE GERMAN VERSION IS BINDING

WEITERGABE SOWIE VERVIELFÄLTIGUNG DIESES DOKUMENTS, VERWERTUNG UND MITTEILUNG SEINES INHALTS SIND VERBOTEN, SOWEIT NICHT AUSDRUECKLICH GESTATTET.  
 ZUWIDERHANDLUNGEN VERPFLICHTEN ZU SCHADENERSATZ. ALLE RECHTE FUER DEN FALL DER PATENT-, GEBRAUCHSMUSTER-, ODER GESCHMACKSMUSTERREINTRAGUNG VORBEHALTEN.  
 THE REPRODUCTION, DISTRIBUTION AND UTILIZATION OF THIS DOCUMENT AS WELL AS THE COMMUNICATION OF ITS CONTENTS TO OTHERS WITHOUT EXPLICIT AUTHORIZATION IS PROHIBITED.  
 OFFENDERS WILL BE HELD LIABLE FOR THE PAYMENT OF DAMAGES. WEIDMUELLER EXCLUSIVELY RESERVES THE RIGHT TO FILE FOR PATENTS, UTILITY MODELS OR DESIGNS.  
 © WEIDMUELLER INTERFACE GmbH & Co.KG

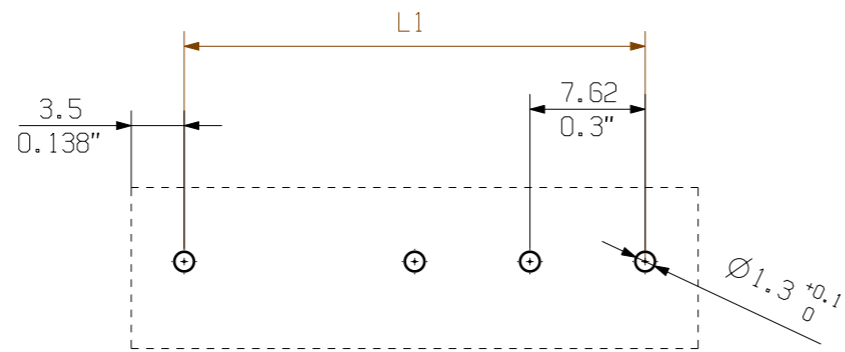
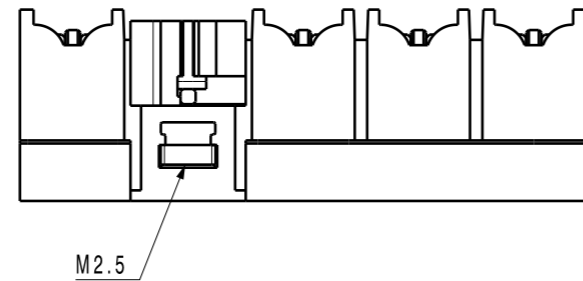
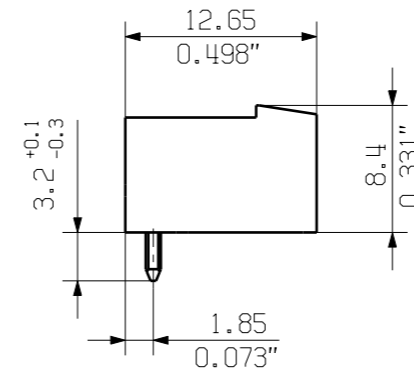
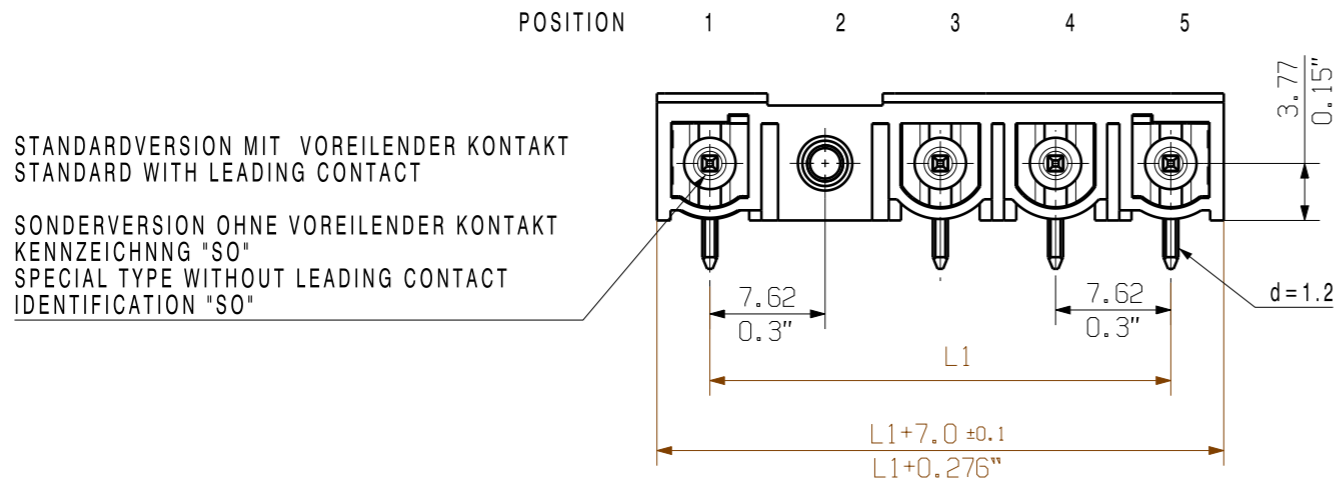

HOLE PATTERN

For the mounting of PCBs, it should be noted that the rated data relates only to the PCB components alone.  
 The necessary creepage and clearance paths must be observed in connection with the respective applicant in accordance to IEC 664 / VDE 0110.  
 The current-carrying capacity and pitch tolerance is to be determined according to DIN IEC 326 part 3 very fine.

Weidmüller PCB components are tested to the DIN EN 61984 standard, and are valid for its field of application.  
 Provided that the components are used to the intended purpose, all requirements with respect to the occurring of electrical, mechanical, thermic and corrosive stress will be satisfied.

M 1/1  
 SL 7.62IT/03/90MF2



SL 7.62IT/04/90MF4

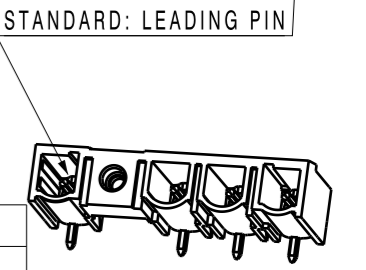
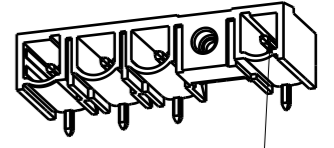

P=POL/POLES  
 MF= MITTELFLANSCH/MIDDLE FLANGE  
 PE=VOREILENDER KONTAKT/ LEADING PIN

3 MF 2	PE	MF	P	P			
3 MF 3	P	P	MF	PE			
4 MF 2	PE	MF	P	P	P		
4 MF 4	P	P	P	MF	PE		
5 MF 3	P	P	P	MF	P	P	
5 MF 4	P	P	MF	P	P	P	
6 MF 3	P	P	MF	P	P	P	P
6 MF 4	P	P	P	MF	P	P	P
6 MF 5	P	P	P	P	MF	P	P
6 MF 6	P	P	P	P	P	MF	P
POLE	1	2	3	4	5	6	7
NO OF POLES	POSITION						

6	45,72	1,80
5	38,10	1,50
4	30,48	1,20
3	22,86	0,90
2	15,24	0,60
n	L1 (mm)	L1 (inch)

SHOWN: SL 7.62IT/04/90MF2

GENERAL TOLERANCE:  
 DIN ISO 2768-m



86757/5  
 10.03.16 HELIS\_MA 00  
 MODIFICATION

**Weidmüller**

CAT.NO.:

**C 49983** 10

DRAWING NO. SHEET 02 OF 04 SHEETS



DATE NAME

DRAWN 18.02.2009 HERTEL\_S

RESPONSIBLE KRUG\_M

CHECKED 04.04.2016 HELIS\_MA

APPROVED LANG\_T

SCALE: 2/1

SUPERSEDES: .

**SL 7.62IT/././90MLF.. 3.2**

STIFTSLEISTE  
 MALE HEADER

PRODUCT FILE: BLZ/SL7.62HP

7375

## Recommended wave soldering profiles

**Weidmüller Interface GmbH & Co. KG**  
 Klängenbergstraße 16  
 D-32758 Detmold  
 Germany  
 Fon: +49 5231 14-0  
 Fax: +49 5231 14-292083  
 www.weidmueller.com

### Single Wave:



### Double Wave:



### Wave soldering profiles

Wired connection elements should be processed in accordance with the DIN EN 61760-1 standard. We have included two recommendations for practical wave soldering profiles, with which Weidmüller PCB terminals and connectors are qualified.

When choosing a suitable profile for your application, the following factors also need to be considered:

- PCB thickness
- Proportion of Cu in the layers
- Single/double-sided assembly
- Product range
- Heating and cooling rates

The single and double wave profiles each indicate the recommended operating range, including the maximum soldering temperature of 260°C. In practice, the maximum soldering temperature is quite often well below the above maximum profile.