

<b>DRAWING NUMBER:</b>	1127-68M-XXXX
<b>PRODUCT GROUP:</b>	TERMINALS
<b>SUB-GROUP:</b>	MILITARY INSULATED TERMINALS
<b>DESCRIPTION:</b>	DIALLYL PHTHALATE INSULATED TURRET TERMINAL

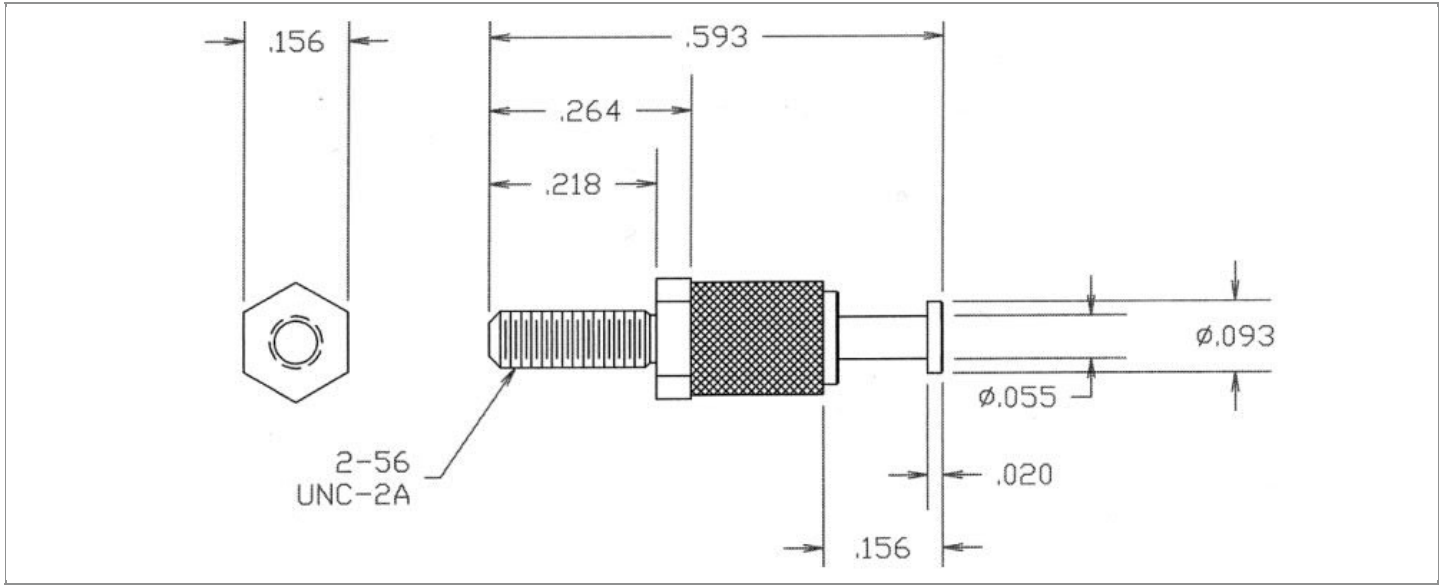

PIN DIAMETER	OVERALL LENGTH	MOUNTING ORIENTATION	BOARD / PANEL MOUNTING METHOD
N/A	0.593"	VERTICAL	THREAD MOUNT (2-56 NUT)
BOARD / PANEL THICKNESS	MOUNTING HOLE SIZE	DRILL SIZE	FEED THRU COMBINATION
UP TO 3/32"	0.094" ± 0.002	3/32"	N/A

**PART NO. STRUCTURE:\***

1127	-	68M	-	XX	XX
PART SERIES		DIMENSION		FINISH	INSULATION COLOR

\*If applicable, "Z" at the end of a PART NO. STRUCTURE indicates TERMINAL MATERIAL TYPE.

**MATERIAL OPTIONS:**

**1127-68M-XXXX**

COMPONENT	MATERIAL	MATERIAL AND SPECIFICATION
TERMINAL	BRASS	BRASS PER ASTM B16, ALLOY C36000, 1/2 HARD
BASE/METAL SLEEVE	BRASS	BRASS PER ASTM B16, ALLOY C36000, 1/2 HARD
INSULATION*	DIALLYL PHTHALATE	MOLDED DIALLYL PHTHALATE, TYPE SDG-F PER ASTM D5948
NUT	BRASS	BRASS PER ASTM B16, ALLOY C36000, 1/2 HARD
WASHER	PHOSPHOR BRONZE	PHOSPHOR BRONZE PER MS35333

\*For Insulation color, please see INSULATION COLOR OPTIONS on Page 2

FINISH - PLATING OPTIONS:

1127-68M-XXXX

FINISH CODE	COMPONENT	FINISH	FINISH AND SPECIFICATION
05	TERMINAL	ELECTRO-SOLDER	0.000300"MIN. ELECTRO-SOLDER PER SAE-AMS-P-81728 OVER 0.000100"MIN. COPPER PER SAE-AMS-2418
	BASE/METAL SLEEVE	ELECTRO-SOLDER	0.000100"MIN. ELECTRO-SOLDER PER SAE-AMS-P-81728 OVER 0.000100"MIN. NICKEL PER SAE-AMS-QQ-N-290
	NUT	NICKEL	0.000100"MIN. NICKEL PER SAE-AMS-QQ-N-290
	WASHER	NICKEL	0.000100"MIN. NICKEL PER SAE-AMS-QQ-N-290
088	TERMINAL	BRIGHT TIN-LEAD	0.000300"MIN. BRIGHT TIN-LEAD (Sn93%-Pb7%) PER ASTM B545 OVER 0.000100"MIN. COPPER PER SAE-AMS-2418
	BASE/METAL SLEEVE	BRIGHT TIN-LEAD	0.000100"MIN. BRIGHT TIN-LEAD (Sn93%-Pb7%) PER ASTM B545 OVER 0.000100"MIN. NICKEL PER SAE-AMS-QQ-N-290
	NUT	NICKEL	0.000100"MIN. NICKEL PER SAE-AMS-QQ-N-290
	WASHER	NICKEL	0.000100"MIN. NICKEL PER SAE-AMS-QQ-N-290
095	TERMINAL	HOT SOLDER DIP	0.000100"MIN. HOT SOLDER DIP USING Sn60 PER IPC-J-STD-006 OVER 0.000100"MIN. COPPER PER SAE-AMS-2418
	BASE/METAL SLEEVE	BRIGHT TIN-LEAD	0.000100"MIN. BRIGHT TIN-LEAD (Sn93%-Pb7%) PER ASTM B545 OVER 0.000100"MIN. NICKEL PER SAE-AMS-QQ-N-290
	NUT	NICKEL	0.000100"MIN. NICKEL PER SAE-AMS-QQ-N-290
	WASHER	NICKEL	0.000100"MIN. NICKEL PER SAE-AMS-QQ-N-290

INSULATION COLOR OPTIONS:

1127-68M-XXXX

INSULATION COLOR	BLACK	BROWN	RED	ORANGE	YELLOW	GREEN	BLUE	VIOLET	GRAY	WHITE
COLOR CODE NO.	10	11	12	13	14	15	16	17	18	19

TOLERANCES:\*

DECIMAL	FRACTIONAL	ANGULAR	DRAWING ORIGATION DATE	LAST MODIFICATION DATE
± 0.015	N/A	N/A	4/30/2001	3/1/2017

\*All dimensions are in inches.

RoHS COMPLIANCE:

1127-68M-05XX

PART NUMBER	RoHS COMPLIANT
1127-68M-0510	NO
1127-68M-0511	NO
1127-68M-0512	NO
1127-68M-0513	NO
1127-68M-0514	NO
1127-68M-0515	NO
1127-68M-0516	NO
1127-68M-0517	NO
1127-68M-0518	NO
1127-68M-0519	NO

1127-68M-088XX

PART NUMBER	RoHS COMPLIANT
1127-68M-08810	NO
1127-68M-08811	NO
1127-68M-08812	NO
1127-68M-08813	NO
1127-68M-08814	NO
1127-68M-08815	NO
1127-68M-08816	NO
1127-68M-08817	NO
1127-68M-08818	NO
1127-68M-08819	NO

1127-68M-095XX

PART NUMBER	RoHS COMPLIANT
1127-68M-09510	NO
1127-68M-09511	NO
1127-68M-09512	NO
1127-68M-09513	NO
1127-68M-09514	NO
1127-68M-09515	NO
1127-68M-09516	NO
1127-68M-09517	NO
1127-68M-09518	NO
1127-68M-09519	NO

MILITARY REFERENCE SPECIFICATIONS:

1127-68M-05XX

PART NUMBER	MIL SPECIFICATION	MIL PART NUMBER	COMMERCIAL ITEM DESCRIPTION (CID) SPECIFICATION	CID PART NUMBER
1127-68M-0510	MIL-T-55155/18	M55155/180H01 (SE180E01S)	A-A-59126/18	AA59126/180H01
1127-68M-0511	MIL-T-55155/18	M55155/181H01 (SE181E01S)	A-A-59126/18	AA59126/181H01
1127-68M-0512	MIL-T-55155/18	M55155/182H01 (SE182E01S)	A-A-59126/18	AA59126/182H01
1127-68M-0513	MIL-T-55155/18	M55155/183H01 (SE183E01S)	A-A-59126/18	AA59126/183H01
1127-68M-0514	MIL-T-55155/18	M55155/184H01 (SE184E01S)	A-A-59126/18	AA59126/184H01
1127-68M-0515	MIL-T-55155/18	M55155/185H01 (SE185E01S)	A-A-59126/18	AA59126/185H01
1127-68M-0516	MIL-T-55155/18	M55155/186H01 (SE186E01S)	A-A-59126/18	AA59126/186H01
1127-68M-0517	MIL-T-55155/18	M55155/187H01 (SE187E01S)	A-A-59126/18	AA59126/187H01
1127-68M-0518	MIL-T-55155/18	M55155/188H01 (SE188E01S)	A-A-59126/18	AA59126/188H01
1127-68M-0519	MIL-T-55155/18	M55155/189H01 (SE189E01S)	A-A-59126/18	AA59126/189H01

1127-68M-088XX

PART NUMBER	MIL SPECIFICATION	MIL PART NUMBER	COMMERCIAL ITEM DESCRIPTION (CID) SPECIFICATION	CID PART NUMBER
1127-68M-08810	MIL-T-55155/18	M55155/180J01	A-A-59126/18	AA59126/180J01 (AA59126/18001)
1127-68M-08811	MIL-T-55155/18	M55155/181J01	A-A-59126/18	AA59126/181J01 (AA59126/18101)
1127-68M-08812	MIL-T-55155/18	M55155/182J01	A-A-59126/18	AA59126/182J01 (AA59126/18201)
1127-68M-08813	MIL-T-55155/18	M55155/183J01	A-A-59126/18	AA59126/183J01 (AA59126/18301)
1127-68M-08814	MIL-T-55155/18	M55155/184J01	A-A-59126/18	AA59126/184J01 (AA59126/18401)

Continued on next page...

MILITARY REFERENCE SPECIFICATIONS CONTINUED:

1127-68M-088XX

PART NUMBER	MIL SPECIFICATION	MIL PART NUMBER	COMMERCIAL ITEM DESCRIPTION (CID) SPECIFICATION	CID PART NUMBER
1127-68M-08815	MIL-T-55155/18	M55155/185J01	A-A-59126/18	AA59126/185J01 (AA59126/18501)
1127-68M-08816	MIL-T-55155/18	M55155/186J01	A-A-59126/18	AA59126/186J01 (AA59126/18601)
1127-68M-08817	MIL-T-55155/18	M55155/187J01	A-A-59126/18	AA59126/187J01 (AA59126/18701)
1127-68M-08818	MIL-T-55155/18	M55155/188J01	A-A-59126/18	AA59126/188J01 (AA59126/18801)
1127-68M-08819	MIL-T-55155/18	M55155/189J01	A-A-59126/18	AA59126/189J01 (AA59126/18901)

1127-68M-095XX

PART NUMBER	MIL SPECIFICATION	MIL PART NUMBER	COMMERCIAL ITEM DESCRIPTION (CID) SPECIFICATION	CID PART NUMBER
1127-68M-09510	MIL-T-55155/18	M55155/180I01	A-A-59126/18	AA59126/180I01
1127-68M-09511	MIL-T-55155/18	M55155/181I01	A-A-59126/18	AA59126/181I01
1127-68M-09512	MIL-T-55155/18	M55155/182I01	A-A-59126/18	AA59126/182I01
1127-68M-09513	MIL-T-55155/18	M55155/183I01	A-A-59126/18	AA59126/183I01
1127-68M-09514	MIL-T-55155/18	M55155/184I01	A-A-59126/18	AA59126/184I01
1127-68M-09515	MIL-T-55155/18	M55155/185I01	A-A-59126/18	AA59126/185I01
1127-68M-09516	MIL-T-55155/18	M55155/186I01	A-A-59126/18	AA59126/186I01
1127-68M-09517	MIL-T-55155/18	M55155/187I01	A-A-59126/18	AA59126/187I01
1127-68M-09518	MIL-T-55155/18	M55155/188I01	A-A-59126/18	AA59126/188I01
1127-68M-09519	MIL-T-55155/18	M55155/189I01	A-A-59126/18	AA59126/189I01

TOOLING:

INSTALLATION TOOL: ARBOR PRESS	INSTALLATION TOOL: ANVIL (ARBOR PRESS OPERATED)	INSTALLATION TOOL: PRESS-FIT / ROLL SWAGE / RIVET PUNCH (ARBOR PRESS OPERATED)	INSTALLATION TOOL: PRESS-FIT (HAND OPERATED)
N/A	N/A	N/A	N/A

NOTES:

<b>DATASHEET NOTES</b>
------------------------

NUT PART NO.: 701-7312-02, WASHER PART NO.: 701-7701-02.

<b>INSTRUCTION NOTES</b>
--------------------------

SUPPLIED WITH NICKEL PLATED BRASS HEX NUT (2-56 x 3/16" x 1/16") AND NICKEL PLATED PHOSPHOR BRONZE #2 INTERNAL TOOTH LOCKWASHER.