

DRAWING NUMBER:	1125-43M-XXXX
PRODUCT GROUP:	TERMINALS
SUB-GROUP:	MILITARY INSULATED TERMINALS
DESCRIPTION:	PTFE INSULATED DOUBLE TURRET TERMINAL

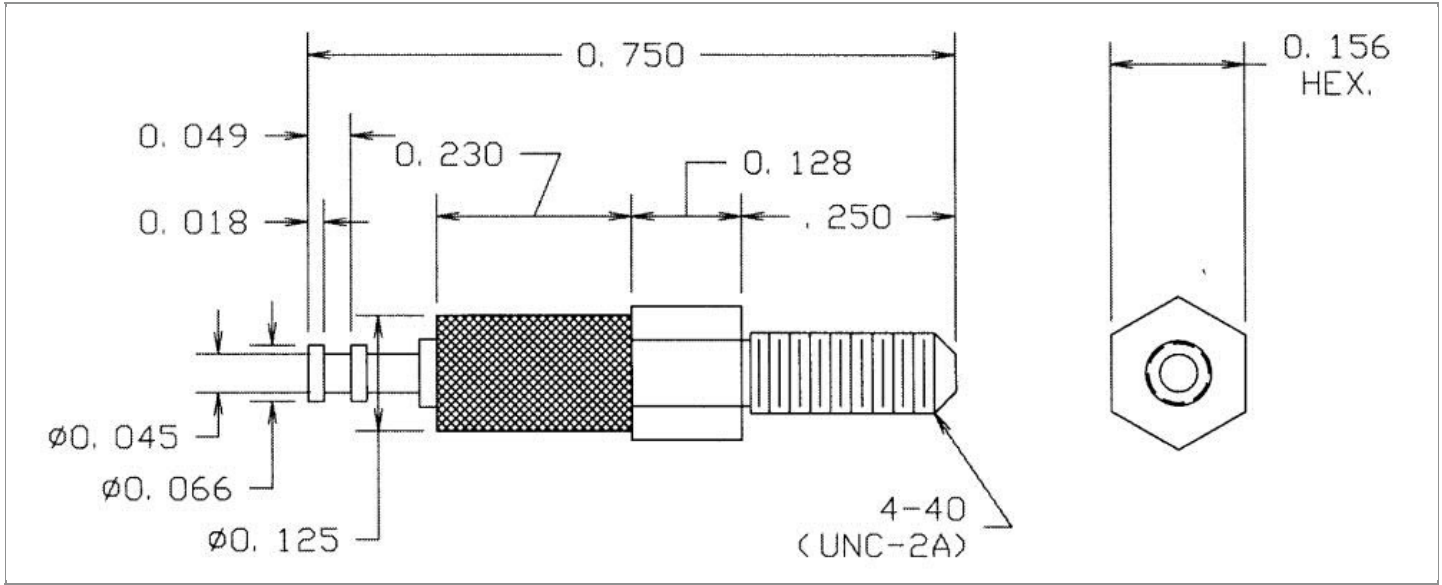

PIN DIAMETER	OVERALL LENGTH	MOUNTING ORIENTATION	BOARD / PANEL MOUNTING METHOD
N/A	0.750"	VERTICAL	THREAD MOUNT (4-40 NUT)
BOARD / PANEL THICKNESS	MOUNTING HOLE SIZE	DRILL SIZE	FEED THRU COMBINATION
UP TO 1/8"	0.120" ± 0.002	#31	N/A

PART NO. STRUCTURE:*

1125	-	43M	-	XX	XX
PART SERIES		DIMENSION		FINISH	INSULATION COLOR

*If applicable, "Z" at the end of a PART NO. STRUCTURE indicates TERMINAL MATERIAL TYPE.

MATERIAL OPTIONS:

1125-43M-XXXX

COMPONENT	MATERIAL	MATERIAL AND SPECIFICATION
TERMINAL	BRASS	BRASS PER ASTM B16, ALLOY C36000, 1/2 HARD
BASE/METAL SLEEVE	BRASS	BRASS PER ASTM B16, ALLOY C36000, 1/2 HARD
INSULATION*	PTFE	PTFE PER ASTM D1710
NUT	BRASS	BRASS PER ASTM B16, ALLOY C36000, 1/2 HARD
WASHER	PHOSPHOR BRONZE	PHOSPHOR BRONZE PER MS35333

*For Insulation color, please see INSULATION COLOR OPTIONS on Page 2

FINISH - PLATING OPTIONS:

1125-43M-XXXX

FINISH CODE	COMPONENT	FINISH	FINISH AND SPECIFICATION
05	TERMINAL	ELECTRO-SOLDER	0.000300"MIN. ELECTRO-SOLDER PER SAE-AMS-P-81728 OVER 0.000100"MIN. COPPER PER SAE-AMS-2418
	BASE/METAL SLEEVE	ELECTRO-SOLDER	0.000100"MIN. ELECTRO-SOLDER PER SAE-AMS-P-81728 OVER 0.000100"MIN. NICKEL PER SAE-AMS-QQ-N-290
	NUT	NICKEL	0.000100"MIN. NICKEL PER SAE-AMS-QQ-N-290
	WASHER	NICKEL	0.000100"MIN. NICKEL PER SAE-AMS-QQ-N-290
088	TERMINAL	BRIGHT TIN-LEAD	0.000300"MIN. BRIGHT TIN-LEAD (Sn93%-Pb7%) PER ASTM B545 OVER 0.000100"MIN. COPPER PER SAE-AMS-2418
	BASE/METAL SLEEVE	BRIGHT TIN-LEAD	0.000100"MIN. BRIGHT TIN-LEAD (Sn93%-Pb7%) PER ASTM B545 OVER 0.000100"MIN. NICKEL PER SAE-AMS-QQ-N-290
	NUT	NICKEL	0.000100"MIN. NICKEL PER SAE-AMS-QQ-N-290
	WASHER	NICKEL	0.000100"MIN. NICKEL PER SAE-AMS-QQ-N-290
095	TERMINAL	HOT SOLDER DIP	0.000100"MIN. HOT SOLDER DIP USING Sn60 PER IPC-J-STD-006 OVER 0.000100"MIN. COPPER PER SAE-AMS-2418
	BASE/METAL SLEEVE	BRIGHT TIN-LEAD	0.000100"MIN. BRIGHT TIN-LEAD (Sn93%-Pb7%) PER ASTM B545 OVER 0.000100"MIN. NICKEL PER SAE-AMS-QQ-N-290
	NUT	NICKEL	0.000100"MIN. NICKEL PER SAE-AMS-QQ-N-290
	WASHER	NICKEL	0.000100"MIN. NICKEL PER SAE-AMS-QQ-N-290

INSULATION COLOR OPTIONS:

1125-43M-XXXX

INSULATION COLOR	BLACK	BROWN	RED	ORANGE	YELLOW	GREEN	BLUE	VIOLET	GRAY	WHITE
COLOR CODE NO.	10	11	12	13	14	15	16	17	18	19

TOLERANCES:*

DECIMAL	FRACTIONAL	ANGULAR	DRAWING ORIGATION DATE	LAST MODIFICATION DATE
± 0.015	N/A	N/A	6/26/1996	3/1/2017

*All dimensions are in inches.

RoHS COMPLIANCE:

1125-43M-05XX

PART NUMBER	RoHS COMPLIANT
1125-43M-0510	NO
1125-43M-0511	NO
1125-43M-0512	NO
1125-43M-0513	NO
1125-43M-0514	NO
1125-43M-0515	NO
1125-43M-0516	NO
1125-43M-0517	NO
1125-43M-0518	NO
1125-43M-0519	NO

1125-43M-088XX

PART NUMBER	RoHS COMPLIANT
1125-43M-08810	NO
1125-43M-08811	NO
1125-43M-08812	NO
1125-43M-08813	NO
1125-43M-08814	NO
1125-43M-08815	NO
1125-43M-08816	NO
1125-43M-08817	NO
1125-43M-08818	NO
1125-43M-08819	NO

1125-43M-095XX

PART NUMBER	RoHS COMPLIANT
1125-43M-09510	NO
1125-43M-09511	NO
1125-43M-09512	NO
1125-43M-09513	NO
1125-43M-09514	NO
1125-43M-09515	NO
1125-43M-09516	NO
1125-43M-09517	NO
1125-43M-09518	NO
1125-43M-09519	NO

MILITARY REFERENCE SPECIFICATIONS:

1125-43M-05XX

PART NUMBER	MIL SPECIFICATION	MIL PART NUMBER	COMMERCIAL ITEM DESCRIPTION (CID) SPECIFICATION	CID PART NUMBER
1125-43M-0510	MIL-T-55155/09	M55155/090H01 (SE090E01S)	A-A-59126/09	AA59126/090H01
1125-43M-0511	MIL-T-55155/09	M55155/091H01 (SE091E01S)	A-A-59126/09	AA59126/091H01
1125-43M-0512	MIL-T-55155/09	M55155/092H01 (SE092E01S)	A-A-59126/09	AA59126/092H01
1125-43M-0513	MIL-T-55155/09	M55155/093H01 (SE093E01S)	A-A-59126/09	AA59126/093H01
1125-43M-0514	MIL-T-55155/09	M55155/094H01 (SE094E01S)	A-A-59126/09	AA59126/094H01
1125-43M-0515	MIL-T-55155/09	M55155/095H01 (SE095E01S)	A-A-59126/09	AA59126/095H01
1125-43M-0516	MIL-T-55155/09	M55155/096H01 (SE096E01S)	A-A-59126/09	AA59126/096H01
1125-43M-0517	MIL-T-55155/09	M55155/097H01 (SE097E01S)	A-A-59126/09	AA59126/097H01
1125-43M-0518	MIL-T-55155/09	M55155/098H01 (SE098E01S)	A-A-59126/09	AA59126/098H01
1125-43M-0519	MIL-T-55155/09	M55155/099H01 (SE099E01S)	A-A-59126/09	AA59126/099H01

1125-43M-088XX

PART NUMBER	MIL SPECIFICATION	MIL PART NUMBER	COMMERCIAL ITEM DESCRIPTION (CID) SPECIFICATION	CID PART NUMBER
1125-43M-08810	MIL-T-55155/09	M55155/090J01	A-A-59126/09	AA59126/090J01 (AA59126/09001)
1125-43M-08811	MIL-T-55155/09	M55155/091J01	A-A-59126/09	AA59126/091J01 (AA59126/09101)
1125-43M-08812	MIL-T-55155/09	M55155/092J01	A-A-59126/09	AA59126/092J01 (AA59126/09201)
1125-43M-08813	MIL-T-55155/09	M55155/093J01	A-A-59126/09	AA59126/093J01 (AA59126/09301)
1125-43M-08814	MIL-T-55155/09	M55155/094J01	A-A-59126/09	AA59126/094J01 (AA59126/09401)

Continued on next page...

MILITARY REFERENCE SPECIFICATIONS CONTINUED:

1125-43M-088XX

PART NUMBER	MIL SPECIFICATION	MIL PART NUMBER	COMMERCIAL ITEM DESCRIPTION (CID) SPECIFICATION	CID PART NUMBER
1125-43M-08815	MIL-T-55155/09	M55155/095J01	A-A-59126/09	AA59126/095J01 (AA59126/09501)
1125-43M-08816	MIL-T-55155/09	M55155/096J01	A-A-59126/09	AA59126/096J01 (AA59126/09601)
1125-43M-08817	MIL-T-55155/09	M55155/097J01	A-A-59126/09	AA59126/097J01 (AA59126/09701)
1125-43M-08818	MIL-T-55155/09	M55155/098J01	A-A-59126/09	AA59126/098J01 (AA59126/09801)
1125-43M-08819	MIL-T-55155/09	M55155/099J01	A-A-59126/09	AA59126/099J01 (AA59126/09901)

1125-43M-095XX

PART NUMBER	MIL SPECIFICATION	MIL PART NUMBER	COMMERCIAL ITEM DESCRIPTION (CID) SPECIFICATION	CID PART NUMBER
1125-43M-09510	MIL-T-55155/09	M55155/090I01	A-A-59126/09	AA59126/090I01
1125-43M-09511	MIL-T-55155/09	M55155/091I01	A-A-59126/09	AA59126/091I01
1125-43M-09512	MIL-T-55155/09	M55155/092I01	A-A-59126/09	AA59126/092I01
1125-43M-09513	MIL-T-55155/09	M55155/093I01	A-A-59126/09	AA59126/093I01
1125-43M-09514	MIL-T-55155/09	M55155/094I01	A-A-59126/09	AA59126/094I01
1125-43M-09515	MIL-T-55155/09	M55155/095I01	A-A-59126/09	AA59126/095I01
1125-43M-09516	MIL-T-55155/09	M55155/096I01	A-A-59126/09	AA59126/096I01
1125-43M-09517	MIL-T-55155/09	M55155/097I01	A-A-59126/09	AA59126/097I01
1125-43M-09518	MIL-T-55155/09	M55155/098I01	A-A-59126/09	AA59126/098I01
1125-43M-09519	MIL-T-55155/09	M55155/099I01	A-A-59126/09	AA59126/099I01

TOOLING:

INSTALLATION TOOL: ARBOR PRESS	INSTALLATION TOOL: ANVIL (ARBOR PRESS OPERATED)	INSTALLATION TOOL: PRESS-FIT / ROLL SWAGE / RIVET PUNCH (ARBOR PRESS OPERATED)	INSTALLATION TOOL: PRESS-FIT (HAND OPERATED)
N/A	N/A	N/A	N/A

NOTES:

DATASHEET NOTES

NUT PART NO.: 701-7317-02, WASHER PART NO.: 701-7723-02.

INSTRUCTION NOTES

SUPPLIED WITH NICKEL PLATED BRASS HEX NUT (4-40 x 1/4" x 3/32") AND NICKEL PLATED PHOSPHOR BRONZE #4 INTERNAL TOOTH LOCKWASHER.