



## PVDF/PTFE

### Submersible Pressure Transducer AST4530

#### Overview

The AST4530 submersible pressure transducer is constructed using PVDF material and a PTFE diaphragm. Designed to measure liquid level of corrosive liquids, the AST4530 features submersible PVDF cable, cord grip and housing. The AST4530 features a conduit connection for turbulent installations such as on-board ships, turbulent tanks, and rail cars. Voltage and 4-20mA output signals allow users to interface for low current consumption or long distance transmission applications.

The AST4530 is CSA157 certified to Class I Div 1, Groups C and D for use in intrinsically safe areas with an approved barrier, ANSI/ISA 12.27.01 Single Seal Approved and ATEX / IECEx Exia IIB Class I, Zone 0, T4.

CAN/CSA C22.2 No 60079-0:11, ANSI/ISA 60079-0:09, CAN/CSA E60079-11:02, ANSI/ISA 60079-11:11, CAN/CSA C22.2N.157-92, UL 913 (6th Edition).

#### Benefits

- ABS (American Bureau of Shipping) Approved
- Class I Zone 0 Exia IIB T4 Ga (Ta = 0°C to +60°C)
- Excellent liquid and gas compatibility
- Cost effective alternative to ultrasonic & radar sensor technologies
- Works with reflective liquids
- Will not fail due to vapor
- No galvanic corrosion or risk of bacteria

#### Applications

- Chemical totes
- Salt water holding tanks
- Process plants
- Rail-car liquid level monitoring
- Storage tanks

## Environmental Data

### Ambient Temperature: 25°C (77°F) (Unless otherwise specified)

Operating Ambient	0 to 60°C (32 to 140°F)
Storage	0 to 80°C (32 to 176°F)

### Electromagnetic Compatibility (EMC)

Standard	Description	Test Value
EN55011	Radiated Emissions	Class A Group 1, 30-1000 MHz
EN61000-4-2	Electrostatic Discharge Immunity	±8 kV Air Discharge ±4 kV Contact Discharge, VCP, HCP
EN61000-4-3	Radiated Electromagnetic Field Immunity	10V/m, 80-2700 MHz 80% 1kHz AM Modulation
EN61000-4-4	Electrical Fast Transient/Burst Immunity	±2 kV on DC Mains ±1 kV on I/O Ports
EN61000-4-5	Surge Immunity	±0.5 kV, ±1 kV, ±2 kV, DC Line-PE ±0.5 kV, ±1 kV, on I/O Ports & DC Lines
EN61000-4-6	Conducted immunity	3V rms, 0.15-80 MHz, DC Mains 3V rms, 0.15-80 MHz, I/O Ports 80% 1kHz AM Modulation
EN61000-4-8	Power Frequency Magnetic Field Immunity Test	30 A/m @ (50Hz, 60Hz) 3 orthogonal orientations

### Shock, Vibration & Ingress Protection (IP)

Standard	Description	Test Value
EN 60067-2-27	Shock Test	500m/s <sup>2</sup> , 6ms, half sine-wave, 6 shocks (3/direction), horizontal and vertical axis, 12 total shocks
EN 60068-2-6	Sinusoidal Vibration	5-25 Hz, 2mm, 25-150 Hz, 50m/s, Sweep rate: 1 octave/min, Duration: 24 hours/axis (48 hours total), horizontal and vertical axis
EN 60068-2-64	Random Vibration	10-2000 Hz, vibration level: 0.0314 (m/s <sup>2</sup> ) <sup>2</sup> /Hz, 24 hrs/axis (48 hrs total), 2 directions: horizontal and vertical
IEC 60068-2-32	Drop Test	Drop of 1 meter to floor made of concrete. Dropped twice on the threaded end and two times perpendicular to the threaded end.
IP-68	Ingress Protection	Dust-tight, protected against the effects of continuous immersion in water

## Performance

Ambient Temperature: 25°C (77°F) (Unless otherwise specified)

Parameters	MIN	TYP	MAX	UNITS	NOTES
Accuracy	-0.5		+0.5	%Span	1
Zero Error	-1.0		+1.0	%Span	2
Zero Error (1 PSI)	-4.0		+4.0	%Span	2
Span Error	-1.5		+1.5	%Span	3
Span Error (4-20mA)	-2.0		+2.0	%Span	3
Span Error (1 PSI)	-4.0		+240	%Span	3
Thermal Error, Zero	-2.0		+2.0	%Span	4
Thermal Error, Span	-2.0		+2.0	%Span	5
Proof Pressure		2X Rated Pressure		PSI	6
Burst Pressure		5X Rated Pressure		PSI	7
Pressure Cycles	10 Million			Cycles	
Compensated Temp. Range		0 - 55° (32 to 132°)		°C (°F)	

## Electrical Data

Model	AST4530		
Output	4-20mA	1-5VDC	0.5-4.5V Ratiometric
Excitation	10-28VDC	10-28VDC	5.0 ± 0.5VDC
Output Impedance	> 10k Ω	< 100 Ω	< 100 Ω
Current Consumption	-	<10mA	<10mA
Output Noise	-	<2mV, RMS	<2mV RMS
Output Load	0-800Ω	10k Ω, Min.	10k Ω Min.
Reverse Polarity Protection	Yes	Yes	Yes
Bandwidth	DC-250 Hz	DC-1kHz	DC-1kHz

## Notes

1. The maximum deviation from a best fit straight line (BFSL) fitted to the output measured over the pressure range at 25°C. Includes all errors due to pressure non-linearity, hysteresis, and non-repeatability. Span is the algebraic difference between full scale output and zero pressure offset.
2. The maximum variation from the ideal offset measured at 25°C.
3. The maximum variation from the ideal full-scale span measured at 25°C.
4. The maximum variation of offset within the compensated temperature range relative to 25°C.
5. The maximum variation of full-scale span within the compensated temperature range relative to 25°C.
6. The maximum pressure that can be safely applied to the product for it to remain in specification once pressure is returned to the operating pressure range.
7. The maximum pressure that can be applied without causing escape of the pressure media.

### Dimensions & Electrical Connection

Unless otherwise specified, all dimensions are in inches

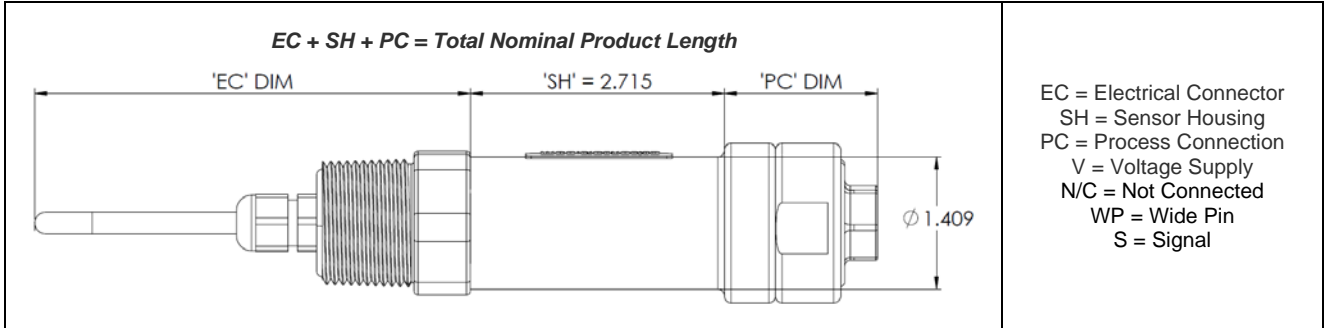

#### Electrical Connectors Option Codes

##### Cable

353 25 FT (7.62m)	354 50 FT (15.24m)	353 75 FT (22.86m)
----------------------	-----------------------	-----------------------

Color	3 Wire Voltage	4-20mA
Green (-SS only)	Case	Case
Black	GND	-V
Red	+V	+V
White	S	N/C

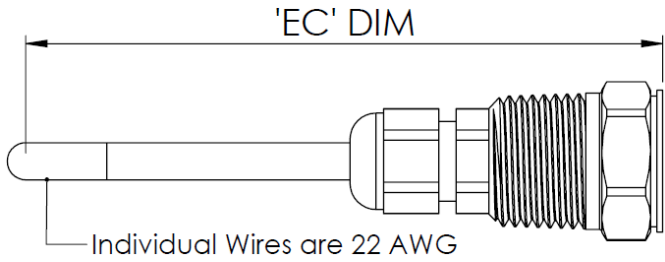

#### Pressure Port Option Codes

##### I 1/4 NPT Female

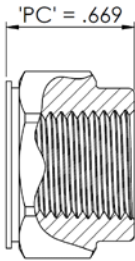

\*Not intended for threaded installation

Dimensions

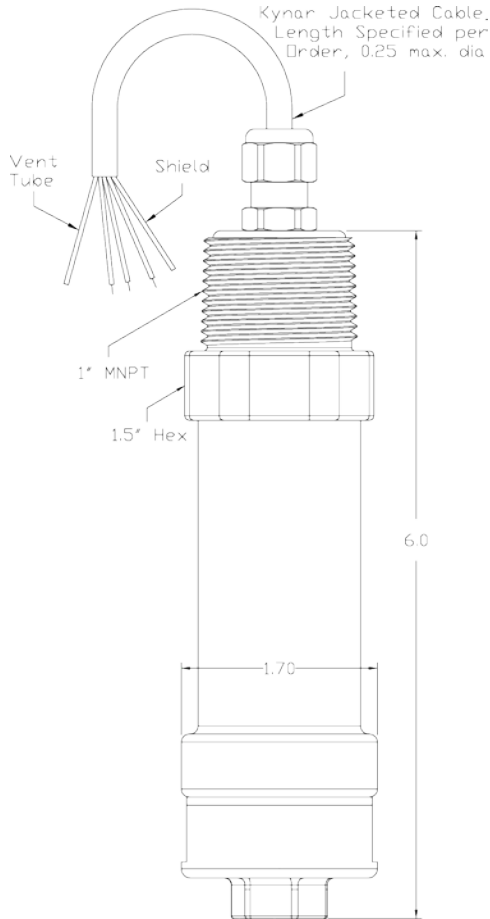

CSA Approved Barrier Installation / A08949

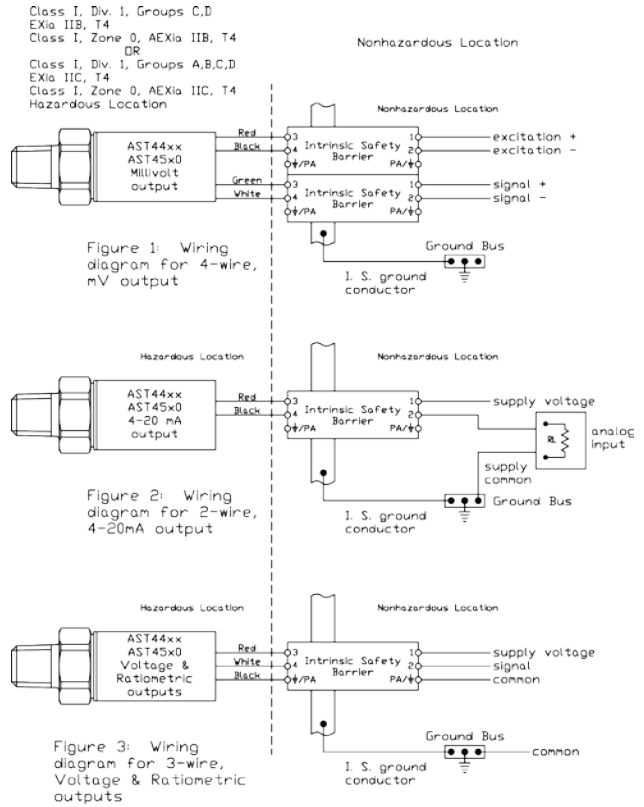

Entity Parameters

Models AST4400, AST44LP, AST4500, AST4510, AST4520, AST4530  
Class I, Div. 1, Groups C,D; EXia IIB, T4; Class I, Zone 0, AEXia IIB, T4  
Vmax = 28Vdc

Model AST4401  
Class I, Div. 1, Groups A,B,C,D; EXia IIC, T4; Class I, Zone 0, AEXia IIC, T4  
Vmax = 14.5Vdc

4-20mA with integral connector	4-20mA with upto 1000ft of integral cable	All EXCEPT 4-20mA with integral connector	All EXCEPT 4-20mA with upto 150ft of integral cable
Pmax = 625 mW Imax = 93 mA Cl = 0.391 uF Li = 0	Pmax = 625 mW Imax = 93 mA Cl = 0.434 uF Li = 155 uH	Pmax = 625 mW Imax = 93 mA Cl = 0.643 uF Li = 0	Pmax = 625 mW Imax = 93 mA Cl = 0.649 uF Li = 23.3 uH

- For installation in accordance with Fig 2, barrier must be a CSA Certified, Single Channel grounded Shunt-Diode Zener Barrier or a Single Channel Isolating Barrier.
- For installations in accordance with Figs. 1 and 3, one dual-channel or two single-channel barriers may be used, where in either case, both channels have been Certified for use together with combined entity parameters.
- The following conditions must be satisfied:
 

$V_{oc}$ or $U_o \leq V_{max}$	$C_a$ or $C_o \geq C_l + C_{cable}$
$I_{sc}$ or $I_o \leq I_{max}$	$L_a$ or $L_o \geq L_l + L_{cable}$
$P_o \leq P_l$ (if applicable)	
- Maximum non-hazardous area voltage must not exceed 250 V.
- Canadian installations should be in accordance with Canadian Electrical Code, Part I. U.S. installations should be in accordance with Article 504 in the National Electrical Code, ANSI/NFPA 70.
- A grounding method is not provided by the manufacturer as part of the integral design of the Transducer. For units which are connected through a grounded shunt diode safety barrier, ensure that the transducer is mounted to a surface which is at the same potential as the barrier ground.
- See user manual for installation conditions.

Legend	
✓	Standard Available
X	Not Available

### Available Process Connection, Material Configurations & Pressure Codes

#### PVDF PSI

Pressure Range	Pressure Range Code	PSI Unit	Process Connection Code
			I
0 - 5	00005	P	✓
0 - 10	00010	P	✓
0 - 15	00015	P	✓
0 - 20	00020	P	✓
0 - 30	00030	P	✓

#### PVDF H2O

Pressure Range	Pressure Range Code	H2O Unit	Process Connection Code
			I
0 - 69	00069	H	✓
0 - 100	00100	H	✓
0 - 120	00120	H	✓
0 - 208	00208	H	✓
0 - 240	00240	H	✓
0 - 360	00360	H	✓
0 - 600	00600	H	✓

\*See Ordering Information for list of options.

## Ordering Information

<b>AST4530</b>	<b>I</b>	<b>00020</b>	<b>P</b>	<b>4</b>	<b>X</b>	<b>9</b>	<b>354</b>
<b>Process Connection</b> I= 1/4" FNPT Not intended for threaded installation							
<b>Pressure Range</b> Insert Pressure Range Code (see table for availability)							
<b>Pressure Unit</b> H= Inches H <sub>2</sub> O P= PSI							
<b>Output</b> 1= 0.5-4.5V ratiometric 3= 1-5V 4= 4-20mA							
<b>Electrical</b> X= See Options Below							
<b>Wetted Material</b> 9= PVDF / PTFE / Viton							
<b>Options (Cable Lengths)</b> 353 = 25 ft. (7.62 m) 354 = 50 ft. (15.24 m) 355 = 75 ft. (22.86 m)							

### NORTH AMERICA

American Sensor Technologies, Inc. (AST),  
a TE Connectivity Company  
Tel: 800-522-6752  
Email: [customercare.molive@te.com](mailto:customercare.molive@te.com)

### ASIA

Hong Kong Sensor Technologies (HKST),  
a TE Connectivity Company  
Tel: 0400-820-6015  
Email: [customercare.shzn@te.com](mailto:customercare.shzn@te.com)

### [TE.com/sensorsolutions](http://TE.com/sensorsolutions)

Measurement Specialties, Inc., a TE Connectivity company.

Measurement Specialties, TE Connectivity, TE Connectivity (logo) and EVERY CONNECTION COUNTS are trademarks. All other logos, products and/or company names referred to herein might be trademarks of their respective owners.

The information given herein, including drawings, illustrations and schematics which are intended for illustration purposes only, is believed to be reliable. However, TE Connectivity makes no warranties as to its accuracy or completeness and disclaims any liability in connection with its use. TE Connectivity's obligations shall only be as set forth in TE Connectivity's Standard Terms and Conditions of Sale for this product and in no case will TE Connectivity be liable for any incidental, indirect or consequential damages arising out of the sale, resale, use or misuse of the product. Users of TE Connectivity products should make their own evaluation to determine the suitability of each such product for the specific application.