



SUBMERSIBLE

Liquid Level Sensors

AST4500 | AST4510

Overview

The AST4500 and AST4510 submersible liquid level sensors are approved to UL/cUL913 (CSA 157) Class I Div 1, Groups C and D for use in intrinsically safe areas with an approved barrier. It is also certified for ATEX / IECEx Class I Zone 0 Exia IIB T4 Ga (Ta = -40°C to +80°C). For pressure ranges from 0-1 to 0-100 PSI that require a wide range of media compatibility, the submersible series is an excellent solution to level monitoring for indoor and outdoor applications.

The AST4500 and AST4510 level sensors are completely sealed for submersion, yet vented through the cable to correct for barometric pressure changes. The welded housing is tested in-house via a helium leak tester to ensure proper protection. The conductors of the cable are also isolated from the outside environment to keep the sensor operational for long-term use.

With a removable nose cone, the AST4500 and AST4510 series can be also be installed outside of the tank through a 1/4" NPT pipe connection. In this configuration, the sensor continuously monitors the tank level through a threaded connection outside the tank, yet remains fully submersible for applications with flood prone environments or severe wash-down conditions. Available with voltage or 4-20mA output signals, AST can provide a cost effective solution for level monitoring for a variety of applications.

Benefits

- High Strength Stainless Steel Construction
- No Internal O-rings
- Wide Operating Temperature
- Pressures up to 100 PSI
- Low Static and Thermal Errors
- Unparalleled Price and Performance
- New Conduit Fitting at Electrical Connection
- Survives Harsh Environments
- Compatible with Wide Variety of Liquids
- EMI/RFI Protection
- ABS (American Bureau of Shipping) Approved

Applications

- Ground Water Level
- Bio-Fuels
- Salt Water Holding Tanks
- Gasoline & Diesel Fuel Tanks
- Fertilizer Tanks
- Earthen & Concrete Dams
- Irrigation Equipment
- Ballast Tanks
- Oil Tanks
- Waste Water Canals

Environmental Data

Ambient Temperature: 25°C (77°F) (Unless otherwise specified)

Operating Ambient	-40 to 80°C (-40 to 176°F)
Storage	-40 to 85°C (-40 to 185°F)

Electromagnetic Compatibility (EMC)

Standards	Description	Test Value
EN55011	Radiated Emissions	Class A, 30-1000 MHz
EN61000-4-2	Electrostatic Discharge Immunity	±8 kV Air Discharge ±4 kV Contact Discharge, VCP, HCP
EN61000-4-3	Radiated Electromagnetic Field Immunity	10V/m, 80-2700 MHz 80% 1kHz AM Modulation
EN61000-4-4	Electrical Fast Transient/Burst Immunity	±0.5 kV, ±1 kV, ±2 kV on DC Mains ±0.5 kV, ±1 kV on I/O Ports
EN61000-4-5	Surge Immunity	±0.5 kV, ±1 kV, on I/O Ports & DC Lines
EN61000-4-6	Conducted immunity	10V rms, 0.15-80 MHz, DC Mains 10V rms, 0.15-80 MHz, I/O Ports 80% 1kHz AM Modulation
EN61000-4-8	Power Frequency Magnetic Field Immunity Test	30 A/m @ (50Hz, 60Hz) 3 orthogonal orientations

Shock, Vibration & Ingress Protection (IP)

Standard	Description	Test Value
EN 60067-2-27	Shock Test	500m/s ² , 6ms, half sine-wave, 6 shocks (3/direction), horizontal and vertical axis, 12 total shocks
EN 60068-2-6	Sinusoidal Vibration	5-25 Hz, 2mm, 25-150 Hz, 50m/s, Sweep rate: 1 octave/min, Duration: 24 hours/axis (48 hours total), horizontal and vertical axis
EN 60068-2-64	Random Vibration	10-2000 Hz, vibration level: 0.0314 (m/s ²) ² /Hz, 24 hrs/axis (48 hrs total), 2 directions: horizontal and vertical
IEC 60068-2-32	Drop Test	Drop of 1 meter to floor made of concrete. Dropped twice on the threaded end and two times perpendicular to the threaded end.
IP-68	Ingress Protection	Dust-tight, protected against the effects of continuous immersion in water

Wetted Materials

Port & Body	Cable & Gland
316L / 304 Stainless Steel	Hytre [®] Cable, Kynar [®] Cord Grip, Viton [®] , Buna-N

Performance

Ambient Temperature: 25°C (77°F) (Unless otherwise specified)

Parameters	MIN	TYP	MAX	UNITS	NOTES
Accuracy	-0.25		+0.25	%Span	1
Accuracy (1 PSI Range Only)	-0.5		+0.5	%Span	1
Zero Error	-1.0		+1.0	%Span	2
Zero Error (1 PSI Range Only)	-4.0		+4.0	%Span	2
Span Error	-1.5		+1.5	%Span	3
Span Error (4-20mA)	-2.0		+2.0	%Span	3
Span Error (1 PSI Range Only)	-4.0		+4.0	%Span	3
Thermal Error, Zero	-1.5		+1.5	%Span	4
Thermal Error, Zero (1 PSI Range Only)	-2.5		+2.5	%Span	4
Thermal Error, Span	-1.5		+1.5	%Span	5
Thermal Error, Span (1 PSI Range Only)	-2.5		+2.5	%Span	5
Stability (1 year)	-0.25		+0.25	%Span	
Proof Pressure		2X Rated Pressure		PSI	6
Burst Pressure		5X Rated Pressure		PSI	7
Pressure Cycles	10 Million			Cycles	
Compensated Temp. Range		0 - 55° (32 to 132°)		°C (°F)	

Electrical Data

Model	AST4500 AST4510	
Output	4-20mA	1-5V
Excitation	10-28VDC	10-28VDC
Output Impedance	> 10k Ω	< 100 Ω
Current Consumption	-	<10mA
Output Noise	-	<2mV, RMS
Output Load	0-800Ω	10k Ω, Min.
Reverse Polarity Protection	Yes	Yes
Bandwidth	DC-250 Hz	DC-1kHz

Notes

1. The maximum deviation from a best fit straight line (BFSL) fitted to the output measured over the pressure range at 25°C. Includes all errors due to pressure non-linearity, hysteresis, and non-repeatability. Span is the algebraic difference between full scale output and zero pressure offset.
2. The maximum variation from the ideal offset measured at 25°C.
3. The maximum variation from the ideal full-scale span measured at 25°C.
4. The maximum variation of offset within the compensated temperature range relative to 25°C.
5. The maximum variation of full-scale span within the compensated temperature range relative to 25°C.
6. The maximum pressure that can be safely applied to the product for it to remain in specification once pressure is returned to the operating pressure range.
7. The maximum pressure that can be applied without causing escape of the pressure media.

Dimensions & Electrical Connection

Unless otherwise specified, all dimensions are in inches

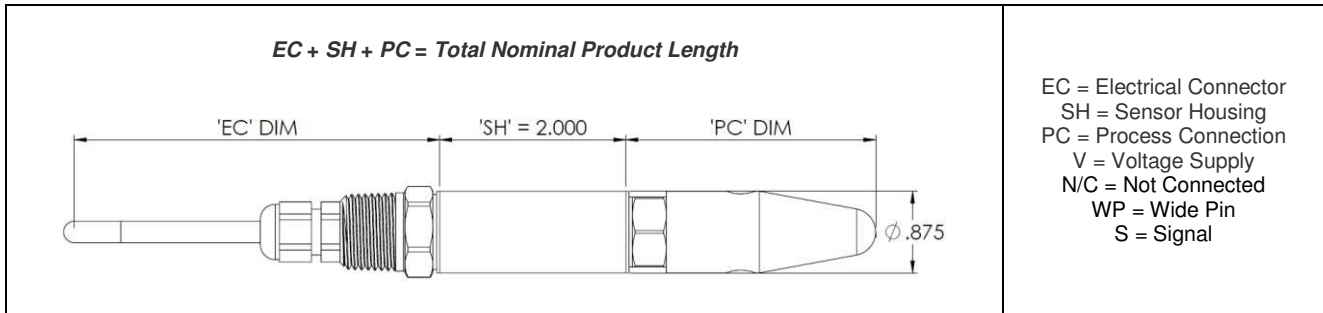

Electrical Connectors Option Codes

Cable

N Conduit Fitting, 6 ft	P Conduit Fitting, 10 ft	X Optional Length (see options)
-----------------------------------	------------------------------------	---

Option Length Codes

140 15 ft (4.6m)	075 20 ft (6.1m)	074 25 ft (7.6m)
004 35 ft (10.7m)	000 No Options	130 40 ft (12.2m)
065 50 ft (15.2m)	003 100 ft (30.5m)	050 150 ft (45.7m)

Color	3 Wire Voltage	4-20mA
Green	N/C	N/C
Green (-SS Only)	Case	Case
Black	GND	-V
Red	+V	+V
White	S	N/C

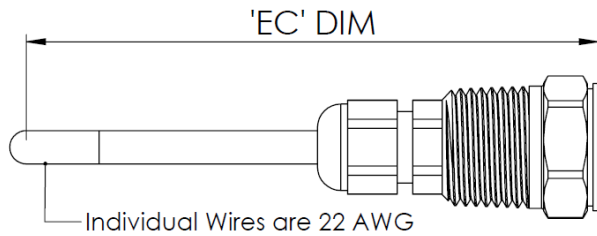

Pressure Port Option Codes

L 1/4 FNPT, Nose Cone	A 1/4 NPT Male
---------------------------------	--------------------------

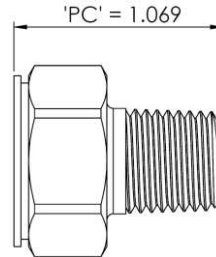
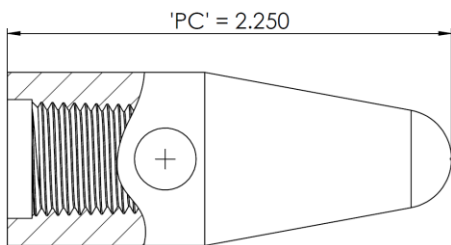

Legend	
✓	Standard Available
X	Not Available

Available Process Connection, Material Configurations & Pressure Codes

316L PSI

	Pressure Range	Pressure Range Code	PSI Unit	Process Connection Code	
				A	L
AST4510	0 - 1	00001	P	✓	✓
	0 - 5	00005	P	✓	✓
	0 - 10	00010	P	✓	✓
	0 - 15	00015	P	✓	✓
AST4500	0 - 25	00025	P	✓	✓
	0 - 50	00050	P	✓	✓
	0 - 100	00100	P	✓	✓

316L H2O

	Pressure Range	Pressure Range Code	H2O Unit	Process Connection Code	
				A	L
AST4510	0 - 24	00024	H	✓	✓
	0 - 48	00048	H	✓	✓
	0 - 69	00069	H	✓	✓
	0 - 100	00100	H	✓	✓
	0 - 120	00120	H	✓	✓
	0 - 208	00208	H	✓	✓
	0 - 240	00240	H	✓	✓
	0 - 360	00360	H	✓	✓
AST4500	0 - 600	00600	H	✓	✓
	0 - 1380	01380	H	✓	✓
	0 - 2770	02770	H	✓	✓

*See Ordering Information for list of options.

UL Approved Barrier Installation / A01657

CSA Approved Barrier Installation / A08949

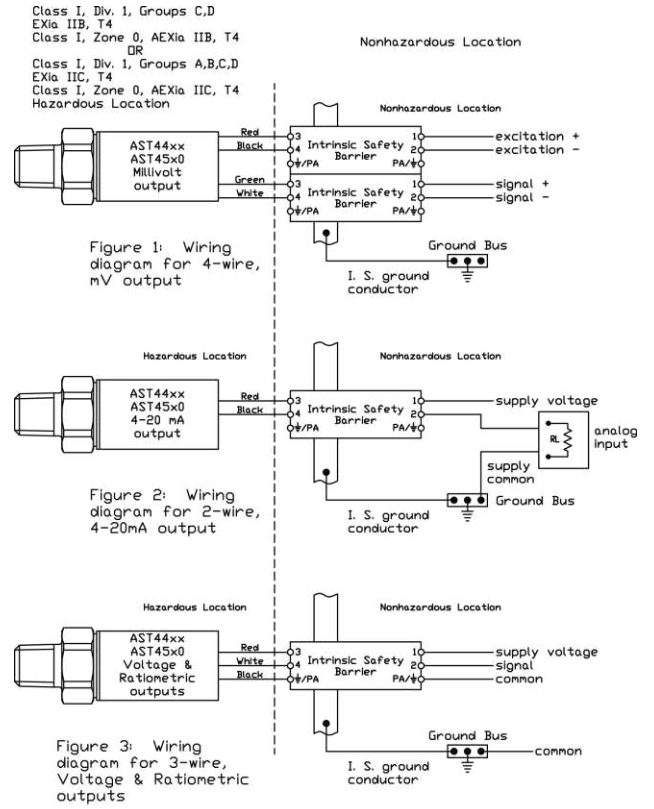
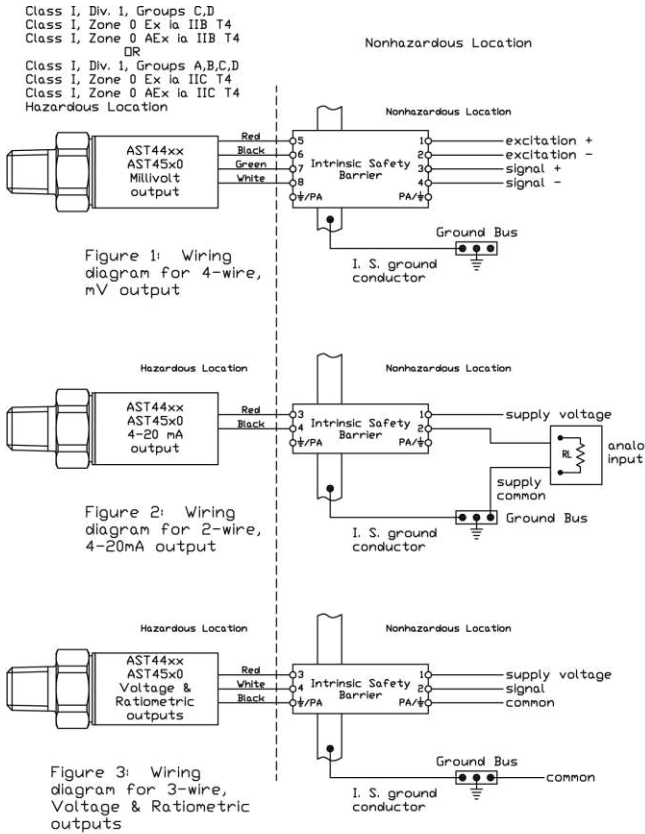

The transducers listed below are designed for installation in EITHER Class I, Division 1, Groups C,D) Class I, Zone 0 Group IIB OR Class I, Division 1, Groups A,B,C,D) Class I, Zone 0 Group IIC hazardous locations when connected to Associated Apparatus as described in note 1.

Entity Parameters

Models AST4400, AST44LP, AST4500, AST4510, AST4520
Class I, Div. 1, Groups C,D) Class I, Zone 0 Ex Ia IIB T4; Class I, Zone 0 AEx Ia IIB T4
Vmax = 28Vdc

Model AST4401
Class I, Div. 1, Groups A,B,C,D) Class I, Zone 0 Ex Ia IIC T4; Class I, Zone 0 AEx Ia IIC T4
Vmax = 14.5Vdc

4-20mA with integral connector	4-20mA with upto 1000ft of integral cable	All EXCEPT 4-20mA with integral connector	All EXCEPT 4-20mA with upto 150ft of integral cable
Pmax = 651 mW Imax = 93 mA Ci = 0.391 uF Li = 0 uH	Pmax = 651 mW Imax = 93 mA Ci = 0.434 uF Li = 0 uH	Pmax = 651 mW Imax = 93 mA Ci = 0.643 uF Li = 0 uH	Pmax = 651 mW Imax = 93 mA Ci = 0.649 uF Li = 0 uH

Isc or Io is the total current available from the Associated Apparatus under any condition.

1. The following conditions must be satisfied:

- Voc or Uo <= Vmax Ca or Co >= Ci + Ccable
 - Isc or Io <= Imax La or Lo >= Li + Lcable
 - Po <= Pi (if applicable)
- Total customer cable length for 4-20mA transmitters not to exceed 4000ft.
Total customer cable length for all other transmitters not to exceed 150ft.
Where the cable capacitance and inductance per foot are not known, the following values shall be used: Ccable = 60pF/ft, Lcable = 0.2uH/ft

2. Control Room apparatus shall not generate in excess of 250V (Umax).

3. Canadian installations should be in accordance with Canadian Electrical Code, Part I. U.S. installations should be in accordance with Article 504 in the National Electrical Code, ANSI/NFPA 70.

Entity Parameters

Models AST4400, AST44LP, AST4500, AST4510, AST4520, AST4530
Class I, Div. 1, Groups C,D) EXia IIB, T4; Class I, Zone 0, AEXia IIB, T4
Vmax = 28Vdc

Model AST4401
Class I, Div. 1, Groups A,B,C,D) EXia IIC, T4; Class I, Zone 0, AEXia IIC, T4
Vmax = 14.5Vdc

4-20mA with integral connector	4-20mA with upto 1000ft of integral cable	All EXCEPT 4-20mA with integral connector	All EXCEPT 4-20mA with upto 150ft of integral cable
Pmax = 625 mW Imax = 93 mA Ci = 0.391 uF Li = 0	Pmax = 625 mW Imax = 93 mA Ci = 0.434 uF Li = 155 uH	Pmax = 625 mW Imax = 93 mA Ci = 0.643 uF Li = 0	Pmax = 625 mW Imax = 93 mA Ci = 0.649 uF Li = 23.3 uH

1. For installation in accordance with Fig 2, barrier must be a CSA Certified, Single Channel grounded Shunt-Diode Zener Barrier or a Single Channel Isolating Barrier.

2. For installations in accordance with Figs. 1 and 3, one dual-channel or two single-channel barriers may be used, where in either case, both channels have been Certified for use together with combined entity parameters.

3. The following conditions must be satisfied:

- Voc or Uo <= Vmax Ca or Co >= Ci + Ccable
- Isc or Io <= Imax La or Lo >= Li + Lcable
- Po <= Pi (if applicable)

4. Maximum non-hazardous area voltage must not exceed 250 V.

5. Canadian installations should be in accordance with Canadian Electrical Code, Part I. U.S. installations should be in accordance with Article 504 in the National Electrical Code, ANSI/NFPA 70.

6. A grounding method is not provided by the manufacturer as part of the integral design of the Transducer. For units which are connected through a grounded shunt diode safety barrier, ensure that the transducer is mounted to a surface which is at the same potential as the barrier ground.

7. See user manual for installation conditions.

INDUSTRIAL OEM

AST4500 | AST4510 Pressure Transmitter

Ordering Information

AST4510 (or AST4500)	L	00005	P	4	N	1	000	-SS
Process Connection L= Front End Cone (Removable) A = 1/4 NPT Male, 7/8 Hex								
Pressure Range Insert Pressure Range Code (see table for availability)								
Pressure Unit H= Inches H ₂ O P= PSI								
Output 3= 1-5V 4= 4-20mA (2 wire loop powered)								
Electrical Connection N= Conduit fitting, Cable 6 ft. P= Conduit fitting, Cable 10 ft. X= Optional Length (see options)								
Wetted Material 1= 316L / 304 / Hytrel Cable / Kynar Cord Grip								
Option Codes (Cable Lengths) 000= No Options 140= 15 ft. (4.6m) 130= 40 ft. (12.2 m) 075= 20 ft. (6.1 m) 065= 50 ft. (15.2 m) 074= 25 ft. (7.6 m) 003= 100 ft. (30.5 m) 004= 35 ft. (10.7 m) 050= 150 ft. (45.7 m)								
Approval Type								
-SS	CSA157 Class I Div 1 Groups C, D & Class I Zone 0, AEx ia IIB T4 Intrinsically Safe when installed with approved barrier, ANSI/ISA 12.27.01 Single Seal and ATEX/IECEX: Ex ia IIB T4							
Leave Blank	UL ANSI/ISA 12.12.01 Class I Div 1 Intrinsically Safe Groups C, D (formerly UL913)]							

Note: CSA approved products require case/earth ground electrical connection. See wiring installation sheet for further details

NORTH AMERICA

American Sensor Technologies, Inc. (AST),
a TE Connectivity Company
Tel: 800-522-6752
Email: customercare.molive@te.com

ASIA

Hong Kong Sensor Technologies (HKST),
a TE Connectivity Company
Tel: 0400-820-6015
Email: customercare.shzn@te.com

TE.com/sensorsolutions

Measurement Specialties, Inc., a TE Connectivity company.

Measurement Specialties, TE Connectivity, TE Connectivity (logo) and EVERY CONNECTION COUNTS are trademarks. All other logos, products and/or company names referred to herein might be trademarks of their respective owners.

The information given herein, including drawings, illustrations and schematics which are intended for illustration purposes only, is believed to be reliable. However, TE Connectivity makes no warranties as to its accuracy or completeness and disclaims any liability in connection with its use. TE Connectivity's obligations shall only be as set forth in TE Connectivity's Standard Terms and Conditions of Sale for this product and in no case will TE Connectivity be liable for any incidental, indirect or consequential damages arising out of the sale, resale, use or misuse of the product. Users of TE Connectivity products should make their own evaluation to determine the suitability of each such product for the specific application.