



## SUBMERSIBLE

### Flush Diaphragm Liquid Level Sensor AST4520

#### Overview

The AST4520 Flush Submersible liquid level sensor is the cost effective solution for level monitoring of turbulent tanks with viscous media. Approved to UL/cUL913 Class 1 Division 1 IS, Groups C and D with an approved barrier, the product ensures a safe, reliable source for level measurement. The AST4520 is also certified to ATEX / IECEx Class I Zone 0 Exia IIB T4 Ga (Ta = -40°C to +80°C).

The AST4520 is offered with pressure ranges from 0-2.5 to 0-15 PSIG. The AST4520 steel cage front end design allows for proper flow of liquids while keeping the sensor at the bottom of the tank or well. With an engraved stainless steel housing and Kynar PVDF cable, this sensor is built to handle the toughest environments.

#### Benefits

- Engraved Housing
- Protective Steel Cage Assembly
- Kynar PVDF Cable
- Compatible with Wide Variety of Chemicals
- Ruggedly Designed for Harsh Waste Water Environments
- Suitable for Waste, Salt, Brackish, or Fresh Water Systems
- EMI/RFI and Reverse Polarity Protection
- Lightning and Surge Protection
- Competitively Priced for OEM Applications
- ABS (American Bureau of Shipping) Approved

#### Applications

- ABS (American Bureau of Shipping) Approved
- Lift Stations - Wastewater, Storm Water, Industrial Applications
- Food Tanks
- Viscous Media Tanks
- Heavy Oil

## INDUSTRIAL OEM

AST4520 Pressure Transmitter

### Environmental Data

#### Ambient Temperature: 25°C (77°F) (Unless otherwise specified)

Operating Ambient	-40 to 80°C (-40 to 176°F)
Storage	-40 to 100°C (-40 to 212°F)

#### Shock, Vibration & Ingress Protection (IP)

Standard	Description	Test Value
EN 60067-2-27	Shock Test	500m/s <sup>2</sup> , 6ms, half sine-wave, 6 shocks (3/direction), horizontal and vertical axis, 12 total shocks
EN 60068-2-6	Sinusoidal Vibration	5-25 Hz, 2mm, 25-150 Hz, 50m/s, Sweep rate: 1 octave/min, Duration: 24 hours/axis (48 hours total), horizontal and vertical axis
EN 60068-2-64	Random Vibration	10-2000 Hz, vibration level: 0.0314 (m/s <sup>2</sup> ) <sup>2</sup> /Hz, 24 hrs/axis (48 hrs total), 2 directions: horizontal and vertical
IEC 60068-2-32	Drop Test	Drop of 1 meter to floor made of concrete. Dropped twice on the threaded end and two times perpendicular to the threaded end.
IP-68	Ingress Protection	Dust-tight, protected against the effects of continuous immersion in water.

#### Wetted Materials

Port & Body	Cable & Gland
316L / 304 Stainless Steel	Hytrel® Cable, Kynar® Cord Grip, Viton®, Buna-N

**Performance**

**Ambient Temperature: 25°C (77°F) (Unless otherwise specified)**

Parameters	MIN	TYP	MAX	UNITS	NOTES
Accuracy	-0.25		+0.25	%Span	1
Zero Error	-1.0		+1.0	%Span	2
Zero Error (1 PSI Range Only)	-4.0		+4.0	%Span	2
Span Error	-1.5		+1.5	%Span	3
Span Error (4-20mA Only)	-2.0		+2.0	%Span	3
Span Error (1 PSI Range Only)	-4.0		+4.0	%Span	3
Thermal Error, Zero	-1.5		+1.5	%Span	4
Thermal Error, Span	-1.5		+1.5	%Span	5
Stability (1 year)		±0.25		%Span	
Proof Pressure		2X Rated Pressure		PSI	6
Burst Pressure		5X Rated Pressure		PSI	7
Pressure Cycles	10 Million			Cycles	
Compensated Temp. Range		0 - 55° (32 to 132°)		°C (°F)	

**Electrical Data**

Model	AST4520	
Output	4-20mA	1-5V
Excitation	10-28VDC	10-28VDC
Output Impedance	> 10k Ω	< 100 Ω
Current Consumption	-	<10mA
Output Noise	-	<2mV RMS
Output Load	0-800Ω	10k Ω Min.
Reverse Polarity Protection	Yes	Yes
Bandwidth	DC-250 Hz	DC-1kHz

**Notes**

1. The maximum deviation from a best fit straight line (BFSL) fitted to the output measured over the pressure range at 25°C. Includes all errors due to pressure non-linearity, hysteresis, and non-repeatability. Span is the algebraic difference between full scale output and zero pressure offset.
2. The maximum variation from the ideal offset measured at 25°C.
3. The maximum variation from the ideal full-scale span measured at 25°C.
4. The maximum variation of offset within the compensated temperature range relative to 25°C.
5. The maximum variation of full-scale span within the compensated temperature range relative to 25°C.
6. The maximum pressure that can be safely applied to the product for it to remain in specification once pressure is returned to the operating pressure range.
7. The maximum pressure that can be applied without causing escape of the pressure media.

**Dimensions & Electrical Connection**

Unless otherwise specified, all dimensions are in inches

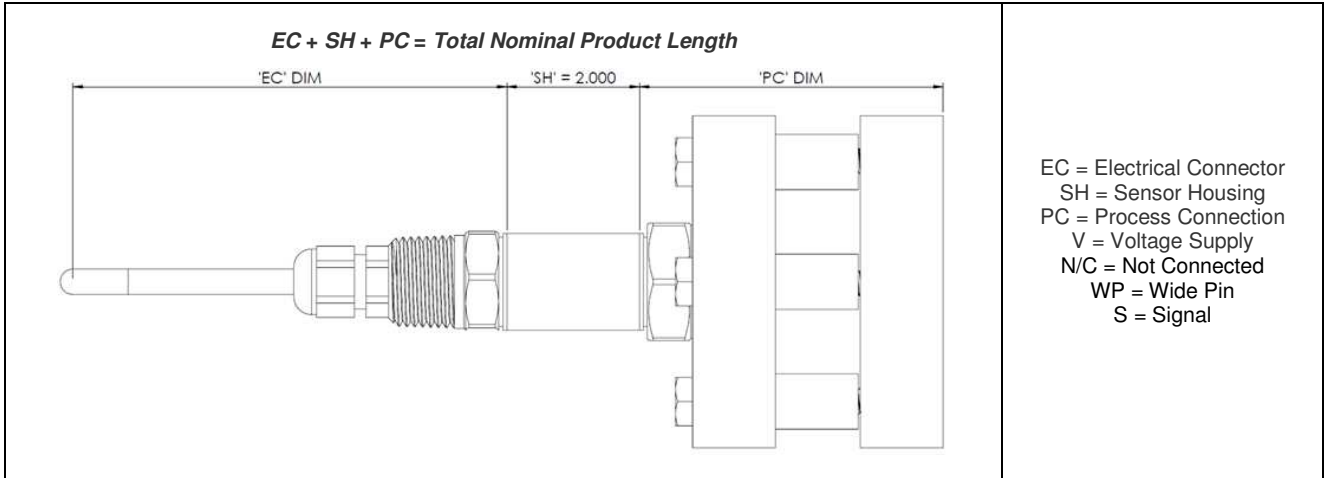

**Electrical Connectors Option Codes**

**Cable**

<b>353</b> 25ft (7.62m)	<b>354</b> 50ft (15.24m)	<b>355</b> 75ft (22.86m)
----------------------------	-----------------------------	-----------------------------

Color	3 Wire Voltage	4-20mA
Green (-SS Only)	Case	Case
Black	GND	-V
Red	+V	+V
White	S	N/C

Individual Wires are 22 AWG

**Pressure Port Option Codes**

<b>Y</b> <b>G1/2 With Steel Cage</b>	<b>T</b> <b>G1/2 Flush Diaphragm Without Steel Cage</b>
---	--

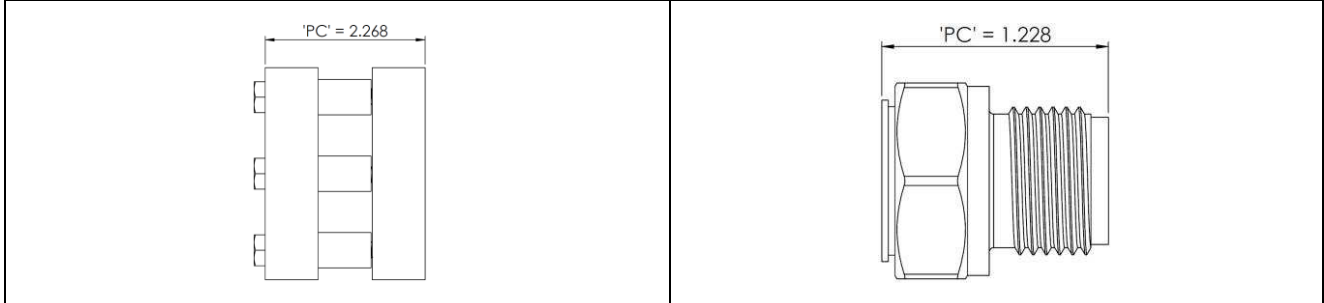

**UL Approved Barrier Installation / A01657**

**CSA Approved Barrier Installation / A08949**

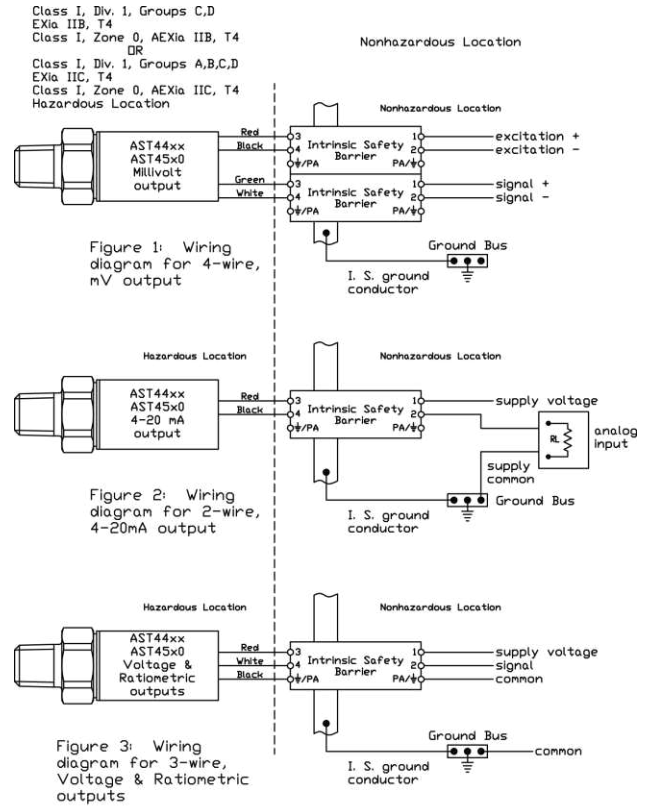
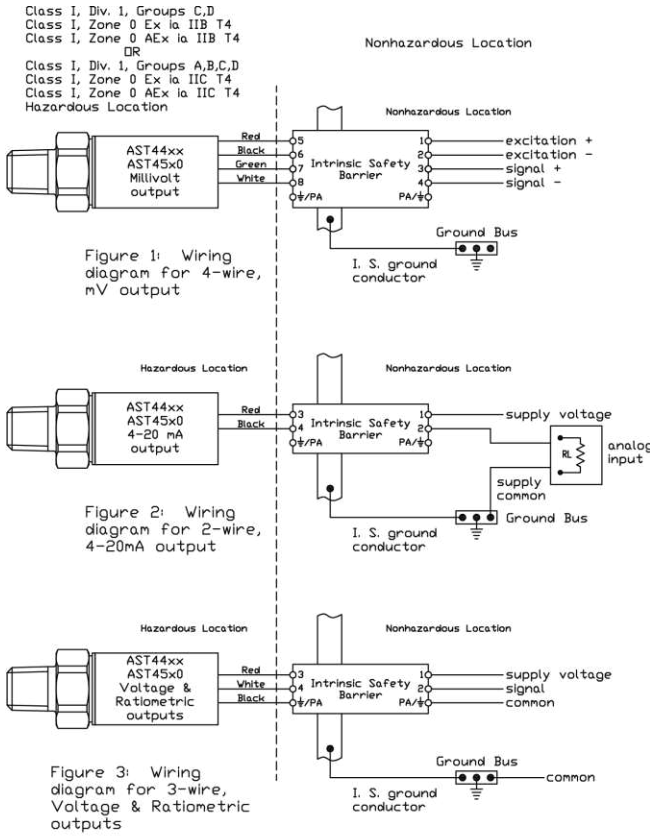

The transducers listed below are designed for installation in EITHER Class I, Division 1, Groups C,D) Class I, Zone 0 Group IIB OR Class I, Division 1, Groups A,B,C,D) Class I, Zone 0 Group IIC hazardous locations when connected to Associated Apparatus as described in note 1.

**Entity Parameters**

Models AST4400, AST44LP, AST4500, AST4510, AST4520

Class I, Div. 1, Groups C,D) Class I, Zone 0 Ex Ia IIB T4; Class I, Zone 0 AEx Ia IIB T4  
Vmax = 28Vdc

Model AST4401

Class I, Div. 1, Groups A,B,C,D) Class I, Zone 0 Ex Ia IIC T4; Class I, Zone 0 AEx Ia IIC T4  
Vmax = 14.5V

4-20mA with integral connector	4-20mA with upto 1000ft of integral cable	All EXCEPT 4-20mA with integral connector	All EXCEPT 4-20mA with upto 150ft of integral cable
Pmax = 651 mW Imax = 93 mA Ci = 0.391 uF Li = 0 uH	Pmax = 651 mW Imax = 93 mA Ci = 0.434 uF Li = 0 uH	Pmax = 651 mW Imax = 93 mA Ci = 0.643 uF Li = 0 uH	Pmax = 651 mW Imax = 93 mA Ci = 0.649 uF Li = 0 uH

Isc or Io is the total current available from the Associated Apparatus under any condition.

1. The following conditions must be satisfied:

$$V_{oc} \text{ or } U_o \leq V_{max} \quad C_a \text{ or } C_o \geq C_i + C_{cable}$$

$$I_{sc} \text{ or } I_o \leq I_{max} \quad L_a \text{ or } L_o \geq L_i + L_{cable}$$

$$P_o \leq P_i \text{ (if applicable)}$$

Total customer cable length for 4-20mA transmitters not to exceed 4000ft.  
Total customer cable length for all other transmitters not to exceed 150ft.  
Where the cable capacitance and inductance per foot are not known, the following values shall be used: Ccable = 60pF/ft, Lcable = 0.2uH/ft

2. Control Room apparatus shall not generate in excess of 250V (Umax).

3. Canadian installations should be in accordance with Canadian Electrical Code, Part I. U.S. installations should be in accordance with Article 504 in the National Electrical Code, ANSI/NFPA 70.

**Entity Parameters**

Models AST4400, AST44LP, AST4500, AST4510, AST4520, AST4530

Class I, Div. 1, Groups C,D) EXia IIB, T4; Class I, Zone 0, AEXia IIB, T4  
Vmax = 28Vdc

Model AST4401

Class I, Div. 1, Groups A,B,C,D) EXia IIC, T4; Class I, Zone 0, AEXia IIC, T4  
Vmax = 14.5Vdc

4-20mA with integral connector	4-20mA with upto 1000ft of integral cable	All EXCEPT 4-20mA with integral connector	All EXCEPT 4-20mA with upto 150ft of integral cable
Pmax = 625 mW Imax = 93 mA Ci = 0.391 uF Li = 0	Pmax = 625 mW Imax = 93 mA Ci = 0.434 uF Li = 155 uH	Pmax = 625 mW Imax = 93 mA Ci = 0.643 uF Li = 0	Pmax = 625 mW Imax = 93 mA Ci = 0.649 uF Li = 23.3 uH

1. For installation in accordance with Fig 2, barrier must be a CSA Certified, Single Channel grounded Shunt-Diode Zener Barrier or a Single Channel Isolating Barrier.

2. For installations in accordance with Figs. 1 and 3, one dual-channel or two single-channel barriers may be used, where in either case, both channels have been Certified for use together with combined entity parameters.

3. The following conditions must be satisfied:

$$V_{oc} \text{ or } U_o \leq V_{max} \quad C_a \text{ or } C_o \geq C_i + C_{cable}$$

$$I_{sc} \text{ or } I_o \leq I_{max} \quad L_a \text{ or } L_o \geq L_i + L_{cable}$$

$$P_o \leq P_i \text{ (if applicable)}$$

4. Maximum non-hazardous area voltage must not exceed 250 V.

5. Canadian installations should be in accordance with Canadian Electrical Code, Part I. U.S. installations should be in accordance with Article 504 in the National Electrical Code, ANSI/NFPA 70.

6. A grounding method is not provided by the manufacturer as part of the integral design of the Transducer. For units which are connected through a grounded shunt diode safety barrier, ensure that the transducer is mounted to a surface which is at the same potential as the barrier ground.

7. See user manual for installation conditions.

Legend	
✓	Standard Available
X	Not Available

**Available Process Connection, Material Configurations & Pressure Codes**

**316L PSI**

Pressure Range	Pressure Range Code	PSI Unit	Process Connection Code	
			T	Y
0 - 5	00005	P	✓	✓
0 - 10	00010	P	✓	✓
0 - 15	00015	P	✓	✓

**316L H2O**

Pressure Range	Pressure Range Code	H2O Unit	Process Connection Code	
			T	Y
0 - 69	00069	H	✓	✓
0 - 100	00100	H	✓	✓
0 - 120	00120	H	✓	✓
0 - 208	00208	H	✓	✓
0 - 240	00240	H	✓	✓
0 - 360	00360	H	✓	✓

\*See Ordering Information for list of options.

## INDUSTRIAL OEM

AST4520 Pressure Transmitter

### Ordering Information

<b>AST4520</b>	<b>Y</b>	<b>00005</b>	<b>P</b>	<b>4</b>	<b>X</b>	<b>1</b>	<b>353</b>	<b>-SS</b>
<b>Process Connection</b> Y= G1/2 with steel cage T= G1/2 flush diaphragm without steel cage								
<b>Pressure Range</b> Insert Pressure Range Code (see table for availability)								
<b>Pressure Unit</b> H= Inches H <sub>2</sub> O      P= PSI								
<b>Output</b> 3= 1-5V 4= 4-20mA (2 wire loop powered)								
<b>Electrical Connection</b> X= Optional Length (see options)								
<b>Wetted Material</b> 1= 316L Sensor / 304 SS Housing / Kynar Cable								
<b>Option Codes (Cable Lengths)</b> 353 = 25 ft. (7.62 m) 354 = 50 ft. (15.24 m) 355 = 75 ft. (22.86 m)								
<b>Approval Type</b>								
-SS	CSA157 Class I Div 1 Groups C, D & Class I Zone 0, AEx ia IIB T4 Intrinsically Safe when installed with approved barrier, ANSI/ISA 12.27.01 Single Seal and ATEX/IECEx: Ex ia IIB T4							
Leave Blank	UL ANSI/ISA 12.12.01 Class I Div 1 Intrinsically Safe Groups C, D (formerly UL913)							

Note: CSA approved products require case/earth ground electrical connection. See wiring installation sheet for further details

#### NORTH AMERICA

American Sensor Technologies, Inc. (AST),  
a TE Connectivity Company  
Tel: 800-522-6752  
Email: [customercare.molive@te.com](mailto:customercare.molive@te.com)

#### ASIA

Hong Kong Sensor Technologies (HKST),  
a TE Connectivity Company  
Tel: 0400-820-6015  
Email: [customercare.shzn@te.com](mailto:customercare.shzn@te.com)

#### TE.com/sensorsolutions

Measurement Specialties, Inc., a TE Connectivity company.

Measurement Specialties, TE Connectivity, TE Connectivity (logo) and EVERY CONNECTION COUNTS are trademarks. All other logos, products and/or company names referred to herein might be trademarks of their respective owners.

The information given herein, including drawings, illustrations and schematics which are intended for illustration purposes only, is believed to be reliable. However, TE Connectivity makes no warranties as to its accuracy or completeness and disclaims any liability in connection with its use. TE Connectivity's obligations shall only be as set forth in TE Connectivity's Standard Terms and Conditions of Sale for this product and in no case will TE Connectivity be liable for any incidental, indirect or consequential damages arising out of the sale, resale, use or misuse of the product. Users of TE Connectivity products should make their own evaluation to determine the suitability of each such product for the specific application.