

SV 7.62HP/03/270MSF3 SC/06R SN BK BX
Weidmüller Interfaces GmbH & Co. KG

Postfach 3030

32760 Detmold

Tel. +49 5231 14-0

Fax. +49 5231 14-2083

info@weidmueller.com

www.weidmueller.com

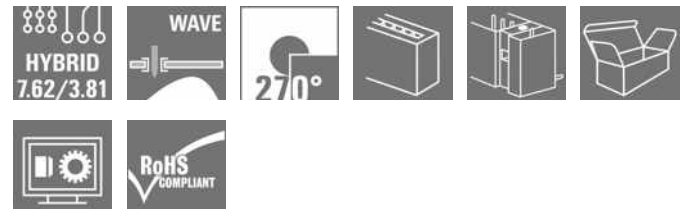
Product image

Combined 270° male header with power and signal contacts incl. self-locking middle flange interlock with a 7.62 pitch.

Enables simultaneous connection of power, signals and (optional) EMC shielding. Ideal for connecting servo and asynchronous drives.

Meets the requirements of IEC 61800-5-1 and enables UL approval as per UL840 600 V when combined with female header BVF 7.62HP/...BCF..R...

Without a female header, the mating profile guarantees minimum power-contact touch-safety of >3 mm with 20 N pressure on the test finger.

The self-locking middle flange reduces the space requirements by one pitch width in comparison with conventional solutions.

Optionally on request: without flange fastening, with additional screw mount or with soldered flange fastening.

General ordering data

Version	PCB plug-in connector, male header, closed side, Middle screw flange, THT solder connection, 7.62 mm, Number of poles: 3, 270°, Solder pin length (l): 3.5 mm, tinned, black, Box
Order No.	1089670000
Type	SV 7.62HP/03/270MSF3 SC/06R SN BK BX
GTIN (EAN)	4032248861378
Qty.	42 pc(s).
Product data	IEC: 1000 V / 41 A UL: 300 V / 35 A
Packaging	Box

SV 7.62HP/03/270MSF3 SC/06R SN BK BX

Weidmüller Interfaces GmbH & Co. KG

Postfach 3030

32760 Detmold

Tel. +49 5231 14-0

Fax. +49 5231 14-2083

info@weidmuller.com

www.weidmuller.com

Technical data

Dimensions and weights

Depth	28.3 mm	Depth (inches)	1.114 inch
Height	14.9 mm	Height (inches)	0.587 inch
Height of lowest version	11.4 mm	Width	42.88 mm
Width (inches)	1.688 inch	Net weight	5.01 g

Temperatures

Operating temperature, min.	-50 °C	Operating temperature, max.	130 °C
-----------------------------	--------	-----------------------------	--------

System specifications

Product family	OMNIMATE Power - series BV/SV 7.62HP	Type of connection	Board connection
Mounting onto the PCB	THT solder connection	Pitch in mm (P)	7.62 mm
Pitch in inches (P)	0.3 inch	Outgoing elbow	270°
Number of poles	3	Number of solder pins per pole	2
Solder pin length (l)	3.5 mm	Solder pin length tolerance	+0.1 / -0.3 mm
Solder pin dimensions	0.8 x 1.0 mm	Solder eyelet hole diameter (D)	1.4 mm
Solder eyelet hole diameter tolerance (D)	+ 0,1 mm	L1 in mm	22.86 mm
L1 in inches	0.9 inch	Number of rows	1
Pin series quantity	1	Touch-safe protection acc. to DIN VDE 57 106	safe to back of hand above the printed circuit board
Touch-safe protection acc. to DIN VDE 0470	IP 20	Volume resistance	2.00 mΩ
Can be coded	Yes	Tightening torque for screw flange, min.	0.2 Nm
Tightening torque for screw flange, max.	0.3 Nm	Plugging cycles	25

Material data

Insulating material	PA GF	Colour	black
Colour chart (similar)	RAL 9011	Insulating material group	II
Comparative Tracking Index (CTI)	≥ 500	UL 94 flammability rating	V-0
Contact material	Copper alloy	Contact surface	tinned
Layer structure of solder connection	1...3 µm Ni / 4...6 µm Sn matt	Layer structure of plug contact	1...3 µm Ni / 4...6 µm Sn matt
Storage temperature, min.	-40 °C	Storage temperature, max.	70 °C
Operating temperature, min.	-50 °C	Operating temperature, max.	130 °C
Temperature range, installation, min.	-25 °C	Temperature range, installation, max.	130 °C

Rated data acc. to IEC

tested acc. to standard	IEC 60664-1, IEC 61984	Rated current, min. number of poles (Tu=20°C)	41 A
Rated current, max. number of poles (Tu=20°C)	41 A	Rated current, min. number of poles (Tu=40°C)	41 A
Rated current, max. number of poles (Tu=40°C)	41 A	Rated voltage for surge voltage class / pollution degree II/2	1,000 V
Rated voltage for surge voltage class / pollution degree III/2	630 V	Rated voltage for surge voltage class / pollution degree III/3	630 V
Rated impulse voltage for surge voltage class/ pollution degree II/2	6 kV	Rated impulse voltage for surge voltage class/ pollution degree III/2	6 kV
Rated impulse voltage for surge voltage class/ contamination degree III/3	6 kV	Short-time withstand current resistance	3 x 1s with 420 A

SV 7.62HP/03/270MSF3 SC/06R SN BK BX

Weidmüller Interfaces GmbH & Co. KG

Postfach 3030

32760 Detmold

Tel. +49 5231 14-0

Fax. +49 5231 14-2083

info@weidmueller.com

Technical data

Rated data acc. to CSA

Institute (CSA)



Certificate No. (CSA)

www.weidmueller.com

200039-1121690

Rated voltage (Use group B / CSA)	300 V
Rated voltage (Use group D / CSA)	600 V
Rated current (Use group C / CSA)	33 A

Rated voltage (Use group C / CSA)	300 V
Rated current (Use group B / CSA)	33 A
Rated current (Use group D / CSA)	5 A

Reference to approval values Specifications are maximum values, details - see approval certificate.

Rated data acc. to UL 1059

Institute (cURus)



Certificate No. (cURus)

E60693

Rated voltage (Use group B / UL 1059)	300 V
Rated voltage (Use group D / UL 1059)	600 V
Rated current (Use group C / UL 1059)	35 A

Rated voltage (Use group C / UL 1059)	300 V
Rated current (Use group B / UL 1059)	35 A
Rated current (Use group D / UL 1059)	5 A

Clearance distance, min. 6.9 mm
 Reference to approval values Specifications are maximum values, details - see approval certificate.

Creepage distance, min. 9.6 mm

Packing

Packaging	Box	VPE length	349 mm
VPE width	135 mm	VPE height	41 mm

Technical data - hybrid

Pitch in mm (hybrid)	nominal	3.81 mm	
	Hybrid component	Signal	
Pitch in mm (Signal)	3.81 mm		
Pitch in inch (hybrid)	nominal	0.15 inch	
	Hybrid component	Signal	
Pitch in inches (Signal)	0.15 inch		
Pole count (hybrid)	nominal	6	
	Hybrid component	Signal	
Number of poles (Signal)	6		
Number of solder pins per pole (hybrid)	Hybrid component	Signal	
	nominal	1	
Number of solder pins per pole (Signal)	1		
Solder pin dimensions (hybrid)	Solder pin dimensions	0.8 x 0.8 mm	
	Hybrid component	Signal	
Solder pin dimensions (Signal)	0.8 x 0.8 mm		
Solder pin dimensions = d tolerance (hybrid)	Solder pin dimensions = d tolerance	Lower tolerance with prefix (reveals minimum)	-0,03
		Upper tolerance with prefix (reveals maximum)	+0,01
		Tolerance, unit	mm
	Hybrid component	Signal	

Creation date May 2, 2023 9:23:15 AM CEST

SV 7.62HP/03/270MSF3 SC/06R SN BK BX

Weidmüller Interfaces GmbH & Co. KG

Postfach 3030

32760 Detmold

Tel. +49 5231 14-0

Fax. +49 5231 14-2083

info@weidmueller.com

www.weidmueller.com

Technical data

Solder pin dimensions = d tolerance (Signal)	-0,03 / +0,01 mm		
Diameter of solder eyelet (hybrid)	Hybrid component	Signal	
	nominal	1.3 mm	
PCB hole diameter (Signal)	1.3 mm		
Tolerance of the diameter of the solder eyelet (hybrid)	Hybrid component	Signal	
	Solder eyelet hole diameter tolerance (D)	± 0.1 mm	
PCB hole diameter tolerance (Signal)	± 0.1 mm		
L2 in mm	7.62 mm		
L2 in inch	0.3 inch		
Number of rows (hybrid)	Hybrid component	Signal	
Number of rows (Signal)	2		
Contact material (hybrid)	Hybrid component	Signal	
	Contact material	CuMg	
Contact material (Signal)	CuMg		
Contact surface (hybrid)	Hybrid component	Signal	
	Contact surface	tinned	
Contact surface (Signal)	tinned		
Layer structure of the solder connection (hybrid)	Layer structure of the solder connection	Material	Ni
		Layer strength	min. 1 µ
			max. 3 µ
		Material	Sn
		Layer strength	min. 4 µ
max. 8 µ			
Hybrid component	Signal		
Layer structure of the solder connection (Signal)	1-3 µ Ni / 4-8 µ Sn		
Layer structure of the plug contact (hybrid)	Layer structure of the plug contact	Material	Ni
		Layer strength	min. 1 µ
			max. 3 µ
		Material	Sn
		Layer strength	min. 4 µ
max. 8 µ			
Hybrid component	Signal		
Layer structure of the plug contact (Signal)	1-3 µ Ni / 4-8 µ Sn		
Rated voltage for overvoltage class / pollution severity level II/2 (hybrid)	Hybrid component	Signal	
	nominal	320 V	
Rated voltage for overvoltage class / pollution severity level II/2 (Signal)	320 V		
Rated voltage for overvoltage class / pollution severity level III/2 (hybrid)	Hybrid component	Signal	
	nominal	160 V	
Rated voltage for overvoltage class / pollution severity level III/2 (Signal)	160 V		
Rated voltage for overvoltage class / pollution severity level III/3 (hybrid)	Hybrid component	Signal	
	nominal	160 V	
Rated voltage for overvoltage class / pollution severity level III/3 (Signal)	160 V		
Rated impulse voltage for overvoltage class / pollution severity level II/2 (hybrid)	Hybrid component	Signal	
	nominal	2.5 kV	
Rated impulse voltage for overvoltage class / pollution severity level II/2 (Signal)	2.5 kV		
Rated impulse voltage for overvoltage class / pollution severity level III/2 (hybrid)	Hybrid component	Signal	
	nominal	2.5 kV	

SV 7.62HP/03/270MSF3 SC/06R SN BK BX

Weidmüller Interfaces GmbH & Co. KG

Postfach 3030

32760 Detmold

Tel. +49 5231 14-0

Fax. +49 5231 14-2083

info@weidmueller.com

Technical data

Rated impulse voltage for overvoltage class/pollution severity level III/2 (Signal)	2.5 kV	
Rated impulse voltage for overvoltage class / pollution severity level III/3 (hybrid)	Hybrid component	Signal www.weidmueller.com
	nominal	2.5 kV
Rated impulse voltage for overvoltage class/pollution severity level III/3 (Signal)	2.5 kV	
Rated current, number of poles (Tu=40°C) (hybrid)	Hybrid component	Signal
	min.	12.7 A
Rated current, number of poles (Tu=20°C) (hybrid)	Hybrid component	Signal
	min.	14.2 A
Short-time withstand current capacity (hybrid)	Short-time withstand current resistance	3 x 1s with 80 A
	Hybrid component	Signal
Short-time withstand current resistance (Signal)	3 x 1s with 80 A	
Creepage distance (hybrid)	Hybrid component	Signal
	min.	4.38 mm
Clearance distance (hybrid)	Hybrid component	Signal
	min.	3.6 mm
Rated voltage (Use group B / CSA) (Hybrid)	Hybrid component	Signal
	nominal	300 V
Rated voltage (Use group B / CSA) (Signal)	300 V	
Rated voltage (Use group C / CSA) (Hybrid)	Hybrid component	Signal
	nominal	50 V
Rated voltage (Use group C / CSA) (Signal)	50 V	
Rated current (Use group B / CSA) (Hybrid)	Hybrid component	Signal
	nominal	9 A
Rated current (Use group B / CSA) (Signal)	9 A	
Rated current (Use group C / CSA) (Hybrid)	Hybrid component	Signal
	nominal	9 A
Rated current (Use group C / CSA) (Signal)	9 A	
Rated current (Use group D / CSA) (Hybrid)	Hybrid component	Signal
	nominal	9 A
Rated current (Use group D / CSA) (Signal)	9 A	
Rated voltage (Use group B / UL 1059) (Hybrid)	Hybrid component	Signal
	nominal	300 V
Rated voltage (Use group B / UL 1059) (Signal)	300 V	
Rated voltage (Use group C / UL 1059) (Hybrid)	Hybrid component	Signal
	nominal	50 V
Rated voltage (Use group C / UL 1059) (Signal)	50 V	
Rated voltage (Use group D / UL 1059) (Hybrid)	Hybrid component	Signal
Rated current (Use group B / UL 1059) (Hybrid)	Hybrid component	Signal
	nominal	5 A
Rated current (Use group B / UL 1059) (Signal)	5 A	
Rated current (Use group C / UL 1059) (Hybrid)	Hybrid component	Signal
	nominal	5 A

SV 7.62HP/03/270MSF3 SC/06R SN BK BX

Weidmüller Interfaces GmbH & Co. KG

Postfach 3030

32760 Detmold

Tel. +49 5231 14-0

Fax. +49 5231 14-2083

info@weidmueller.com

Signal

www.weidmueller.com

Technical data

Rated current (Use group C / UL 1059) 5 A
(Signal)

Rated current (Use group D / UL 1059) | Hybrid component
(Hybrid)

Classifications

ETIM 6.0	EC002637	ETIM 7.0	EC002637
ETIM 8.0	EC002637	ECLASS 9.0	27-44-04-02
ECLASS 9.1	27-44-04-02	ECLASS 10.0	27-44-04-02
ECLASS 11.0	27-46-02-01	ECLASS 12.0	27-46-03-01

Important note

IPC conformity

Conformity: The products are developed, manufactured and delivered according international recognized standards and norms and comply with the assured properties in the data sheet resp. fulfill decorative properties in accordance with IPC-A-610 "Class 2". Further claims on the products can be evaluated on request.

Notes

- Technical specifications refer to the power contacts
- Technical data of signal contacts: 50V / 5A, stripping length 8mm
- Rated current related to rated cross-section & min. No. of poles.
- Specifications of diagram: P1=7.62 mm; P2=3.81 mm
- Rated data refer only to the component itself. Clearance and creepage distances to other components are to be designed in accordance with the relevant application standards.
- MFX and MSFX: X= Position of the middle flange e.g. MF2, MSF3
- Long term storage of the product with average temperature of 50 °C and average humidity 70%, 36 months

Approvals

Approvals



ROHS Conform

UL File Number Search UL Website

Certificate No. (cURus) E60693

Data sheet

SV 7.62HP/03/270MSF3 SC/06R SN BK BX

Weidmüller Interfaces GmbH & Co. KG

Postfach 3030

32760 Detmold

Tel. +49 5231 14-0

Fax. +49 5231 14-2083

info@weidmueller.com

www.weidmueller.com

Technical data

Downloads

Approval/Certificate/Document of Conformity	Declaration of the Manufacturer
Engineering Data	CAD data – STEP
Engineering Data	WSCAD
Catalogues	Catalogues in PDF-format
Brochures	FL DRIVES EN
	MB DEVICE MANUF. EN
	FL DRIVES DE
	FL HEATING ELECTR EN
	FL APPL INVERTER EN
	FL_BASE_STATION_EN
	FL ELEVATOR EN
	FL POWER SUPPLY EN
	FL 72H SAMPLE SER EN
	PO OMNIMATE EN
	PO OMNIMATE EN

SV 7.62HP/03/270MSF3 SC/06R SN BK BX

Weidmüller Interfaces GmbH & Co. KG

Postfach 3030

32760 Detmold

Tel. +49 5231 14-0

Fax. +49 5231 14-2083

Drawings

Product image

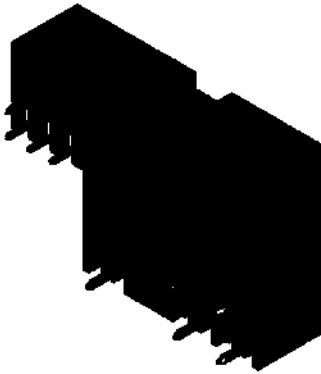

Dimensional drawing info@weidmueller.com

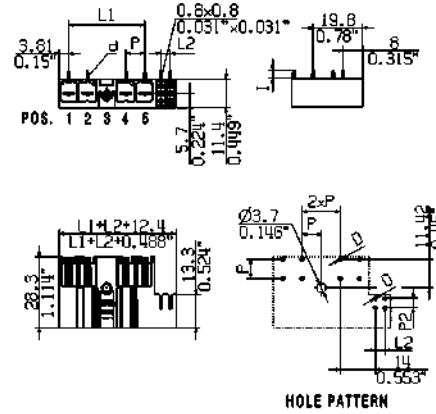

Dimensional drawing

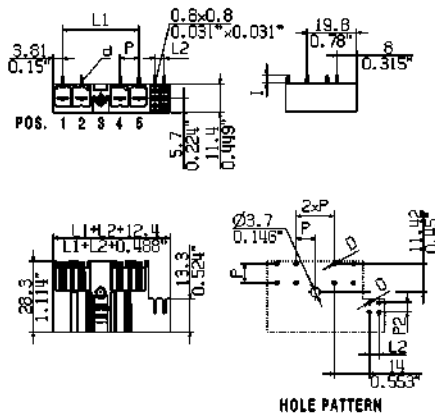

Recommended wave soldering profiles

Weidmüller Interface GmbH & Co. KG
 Klingenbergstraße 16
 D-32758 Detmold
 Germany
 Fon: +49 5231 14-0
 Fax: +49 5231 14-292083
 www.weidmueller.com

Single Wave:



Double Wave:



Wave soldering profiles

Wired connection elements should be processed in accordance with the DIN EN 61760-1 standard. We have included two recommendations for practical wave soldering profiles, with which Weidmüller PCB terminals and connectors are qualified.

When choosing a suitable profile for your application, the following factors also need to be considered:

- PCB thickness
- Proportion of Cu in the layers
- Single/double-sided assembly
- Product range
- Heating and cooling rates

The single and double wave profiles each indicate the recommended operating range, including the maximum soldering temperature of 260°C. In practice, the maximum soldering temperature is quite often well below the above maximum profile.