

Housing - HC-COM-SHOWS-1SGM25-PL-BK - 1079393

Please be informed that the data shown in this PDF Document is generated from our Online Catalog. Please find the complete data in the user's documentation. Our General Terms of Use for Downloads are valid (<http://phoenixcontact.com/download>)



Box mounting bases COM, with single locking latch, material: PA, cable outlets: 1, lateral, height: 36 mm, cable gland: with, support sleeve: no, 1x M25, Standard



Key Commercial Data

Packing unit	1 pc
GTIN	 4 055626 798493
GTIN	4055626798493
Weight per Piece (excluding packing)	60.000 g
Custom tariff number	85389099
Country of origin	China

Technical data

Dimensions

Height	36 mm
Width	49.5 mm
Length	97 mm
Wrench size, union nut	27 mm
External cable diameter	10 mm ... 16 mm
Length of the assembly cutout	25.5 mm
Width of the assembly cutout	23.5 mm

Ambient conditions

Degree of protection (IP)	IP66
Ambient temperature (operation)	-40 °C ... 125 °C

Housing - HC-COM-SHOWS-1SGM25-PL-BK - 1079393

Technical data

General

Size	COM
Housing type	Box mounting bases
Color	black
Locking type	with single locking latch
No. of cable outlets	1
Cable outlet	lateral
Screw connection	with
Type of the screw connection	1x M25
Housing material	PA
Seal material	NBR
Material lock	PA
Flammability rating according to UL 94	V0 (Housing)
	V0 (Interlock)

Drawings

Dimensional drawing

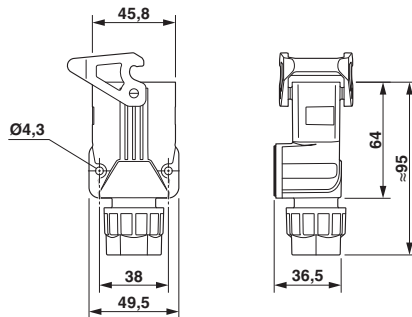

Dimensional drawing

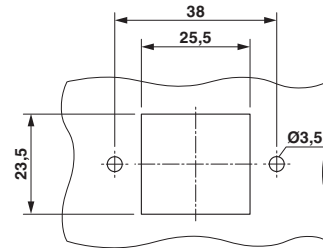

Mounting cutout

Classifications

eCl@ss

eCl@ss 10.0.1	27440202
eCl@ss 11.0	27440202
eCl@ss 4.0	27140816
eCl@ss 4.1	27140816
eCl@ss 5.0	27143424
eCl@ss 5.1	27261200
eCl@ss 6.0	27261200
eCl@ss 7.0	27440202

Housing - HC-COM-SHOWS-1SGM25-PL-BK - 1079393

Classifications

eCl@ss

eCl@ss 9.0	27440202
------------	----------

ETIM

ETIM 4.0	EC000437
ETIM 6.0	EC000437
ETIM 7.0	EC000437

UNSPSC

UNSPSC 6.01	31261502
UNSPSC 7.0901	31261502
UNSPSC 11	31261502
UNSPSC 12.01	31261502
UNSPSC 13.2	31261501
UNSPSC 18.0	31261501
UNSPSC 19.0	31261501
UNSPSC 20.0	31261501
UNSPSC 21.0	31261501

Approvals

Approvals

Approvals

EAC

Ex Approvals

Approval details

EAC		RU C- DE.BL08.B.00511
-----	---	--------------------------