

Safety relays - PSR-MC73-5NO-1DO-24DC-SP - 1015526

Please be informed that the data shown in this PDF Document is generated from our Online Catalog. Please find the complete data in the user's documentation. Our General Terms of Use for Downloads are valid (<http://phoenixcontact.com/download>)



Safety relay for emergency stop, safety doors, light grid up to SILCL 3, Cat. 4, PL e, 1- or 2-channel operation, cross-circuit detection, can be retriggered, fall back/on delay 0.2 s to 300 s, 5 enabling current paths, $U_s = 24 \text{ V DC}$, pluggable Push-in terminal block

Your advantages

- ✓ Up to Cat.4/PL e according to ISO 13849-1, SILCL 3 according to IEC 62061
- ✓ Low housing width of only 22.5mm
- ✓ Single and two-channel control
- ✓ 5 enabling current paths, 1 digital signal output
- ✓ Manually monitored and automatic activation in a single device
- ✓ Time saving push-in connection, tools not required
- ✓ Potentials can be easily looped through – ideal for BUS applications
- ✓ Intuitive use through colour coded actuation lever
- ✓ Can be combined with the MSTB 2,5 range
- ✓ Quick and convenient testing using integrated test option



Key Commercial Data

Packing unit	1
GTIN	 4 055626 496566
GTIN	4055626496566
Custom tariff number	85371098

Technical data

Note

Utilization restriction	EMC: class A product, see manufacturer's declaration in the download area
-------------------------	---

Dimensions

Width	22.5 mm
-------	---------

Safety relays - PSR-MC73-5NO-1DO-24DC-SP - 1015526

Technical data

Dimensions

Height	117.5 mm
Depth	114.5 mm

Ambient conditions

Ambient temperature (operation)	-35 °C ... 60 °C (observe derating)
Ambient temperature (storage/transport)	-40 °C ... 85 °C
Max. permissible relative humidity (operation)	75 % (on average, 85% infrequently, non-condensing)
Max. permissible humidity (storage/transport)	75 % (on average, 85% infrequently, non-condensing)
Maximum altitude	≤ 2000 m (Above sea level)

Power supply

Designation	A1/A2
Rated control circuit supply voltage U_s	24 V DC -20 % / +25 %
Rated control supply current I_s	typ. 80 mA
Power consumption at U_s	typ. 1.92 W
Inrush current	typ. 28 A ($\Delta t = 30 \mu s$ at U_s)
Filter time	10 ms (For the logic. At A1 in the event of voltage dips at U_s)
Protective circuit	Serial protection against polarity reversal Suppressor diode

Digital inputs

Input name	Sensor circuit
	S12, S22
Description of the input	safety-related sensor inputs
	NPN
Number of inputs	2
Input voltage range "0" signal	0 V DC ... 5 V DC
Input voltage range "1" signal	11 V DC ... 30 V DC
Input current range "0" signal	0 mA ... 2 mA
Inrush current	< 11 mA (typically with U_s)
Current consumption	< 4.5 mA (typically with U_s)
Filter time	max. 3 ms (Test pulse width of low test pulses)
	min. 21 ms (Test pulse rate for low test pulse)
Max. permissible overall conductor resistance	150 Ω
Concurrence input 1/2	∞
Limit frequency	min. 0 Hz
	max. 1 Hz
Protective circuit/component	Varistor
Input name	Start circuit
	S34
Description of the input	non-safety-related
	NPN
Number of inputs	1

Safety relays - PSR-MC73-5NO-1DO-24DC-SP - 1015526

Technical data

Digital inputs

Input voltage range "0" signal	0 V DC ... 5 V DC
Input voltage range "1" signal	11 V DC ... 30 V DC
Input current range "0" signal	0 mA ... 2 mA
Inrush current	< 8.6 mA (typically with U _S)
Current consumption	< 3.2 mA (typically with U _S)
Filter time	max. 3 ms (Test pulse width of low test pulses) min. 21 ms (Test pulse rate for low test pulse)
Max. permissible overall conductor resistance	150 Ω
Limit frequency	min. 0 Hz max. 1 Hz
Protective circuit/component	Varistor

Relay outputs: enabling current path

Output name	Enabling current paths 13/14, 23/24/34, 47/48/58
Output description	2 N/O contacts each in series, safety-related, floating
Number of outputs	3 (undelayed: 13/14, 23/24/34) 2 (delayed: 47/48/58)
Contact type	5 enabling current paths
Contact material	AgSnO ₂
Switching voltage	min. 12 V AC/DC max. 250 V AC (Observe the load curve)
Limiting continuous current	6 A
Inrush current	min. 3 mA max. 6 A
Sq. Total current	108 A ² (observe derating)
Switching capacity	min. 60 mW
Switching frequency	0.5 Hz (depending on the set delay time)
Mechanical service life	10x 10 ⁶ cycles
Switching capacity according to IEC 60947-5-1	4 A (24 V (DC13)) 5 A (250 V (AC15))
Output fuse	6 A gL/gG 4 A gL/gG (for low-demand applications)

Alarm outputs

Designation	M1
Output description	PNP non-safety-related
Number of outputs	1
Voltage	approx. 23 V DC (U _S - 1 V)
Current	max. 100 mA

Safety relays - PSR-MC73-5NO-1DO-24DC-SP - 1015526

Technical data

Alarm outputs

Maximum inrush current	500 mA ($\Delta t = 10 \text{ ms}$ at U_s)
Protective circuit/component	Suppressor diode
Short-circuit protection	Yes

Clock outputs

Designation	S11, S21
Output description	PNP
	non-safety-related
Number of outputs	2
Voltage	corresponds to U_s
Current	max. 100 mA
Maximum inrush current	500 mA ($\Delta t = 10 \text{ ms}$ at U_s)
Cable length	max. 150 m
Protective circuit/component	Suppressor diode
Short-circuit protection	Yes

Times

Typical pickup time at US	500 ms (with U_s when controlled via A1)
Typical response time at US	< 40 ms (automatic start)
	< 30 ms (manual, monitored start)
Typical release time at US	< 25 ms (when controlled via S12 and S22 (only for undelayed contacts))
	< 5 ms (when controlled via A1; applicative deactivation via A1/A2 is not permitted)
Delay time range	0.2 s ... 300 s $\pm 5 \%$ (can be set for 47/48/58)
Restart time	< 1 s (Boot time)
Recovery time	500 ms (following demand of the safety function)

General

Relay type	Electromechanical relay with forcibly guided contacts in accordance with IEC/EN 61810-3 (EN 50205)
Nominal operating mode	100% operating factor
Net weight	155.43 g
Mounting position	vertical or horizontal
Mounting type	DIN rail mounting
Assembly instructions	See derating curve
Degree of protection	IP20
Min. degree of protection of inst. location	IP54
Housing material	PBT
Housing color	yellow
Status display	5 x bi-color LED

Connection capacity

Connection method	Push-in spring connection
-------------------	---------------------------

Safety relays - PSR-MC73-5NO-1DO-24DC-SP - 1015526

Technical data

Connection capacity

pluggable	Yes
Conductor cross section solid	0.2 mm ² ... 1.5 mm ²
Conductor cross section flexible	0.2 mm ² ... 1.5 mm ²
Conductor cross section AWG / kcmil	24 ... 16
Conductor cross section flexible, with ferrule without plastic sleeve	0.25 mm ² ... 1.5 mm ² (only together with CRIMPFOX 6)
Conductor cross section, flexible, with ferrule, with plastic sleeve	0.25 mm ² ... 1.5 mm ² (only together with CRIMPFOX 6)
Cylindrical gauge a x b / diameter	2.4 mm x 1.5 mm / 1.9 mm
Stripping length	8 mm

Safety-related characteristic data

Stop category	0
	1
Designation	IEC 61508 - High demand
Safety Integrity Level (SIL)	3
Designation	IEC 61508 - Low demand
Safety Integrity Level (SIL)	3
Designation	EN ISO 13849
Performance level (PL)	e (4 A DC13; 5 A AC15; 8760 switching cycles/year)
Category	4
Designation	EN 62061
Safety Integrity Level Claim Limit (SIL CL)	3

Standards and Regulations

Designation	Air clearances and creepage distances between the power circuits
Standards/regulations	DIN EN 50178
Rated insulation voltage	250 V AC
Rated surge voltage/insulation	Basic insulation 4 kV between all current paths and housing
	Safe isolation, reinforced insulation 6 kV between (A1, A2, S11, S12, S21, S22, S34, M1) and enabling current path (13/14) and enabling current path (23/24/34) and enabling current path (47/48/58)
Degree of pollution	2
Overvoltage category	III
Shock	10g (operation), 15g (transport)
Vibration (operation)	10 Hz ... 150 Hz, 2g
Conformance	CE-compliant

Environmental Product Compliance

REACH SVHC	Lead 7439-92-1
China RoHS	Environmentally Friendly Use Period = 50 years
	For details about hazardous substances go to tab "Downloads", Category "Manufacturer's declaration"

Drawings

Safety relays - PSR-MC73-5NO-1DO-24DC-SP - 1015526

Block diagram

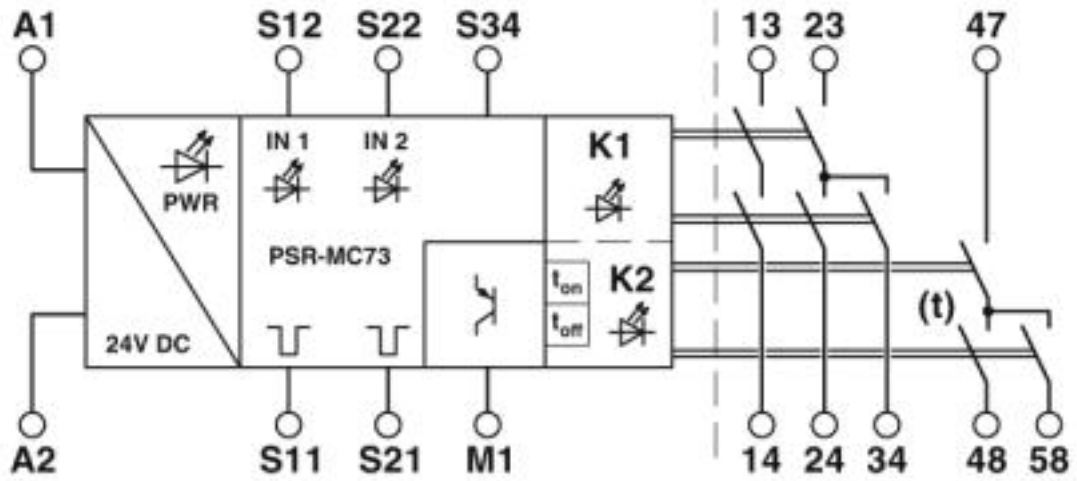

Safety relays - PSR-MC73-5NO-1DO-24DC-SP - 1015526

Circuit diagram

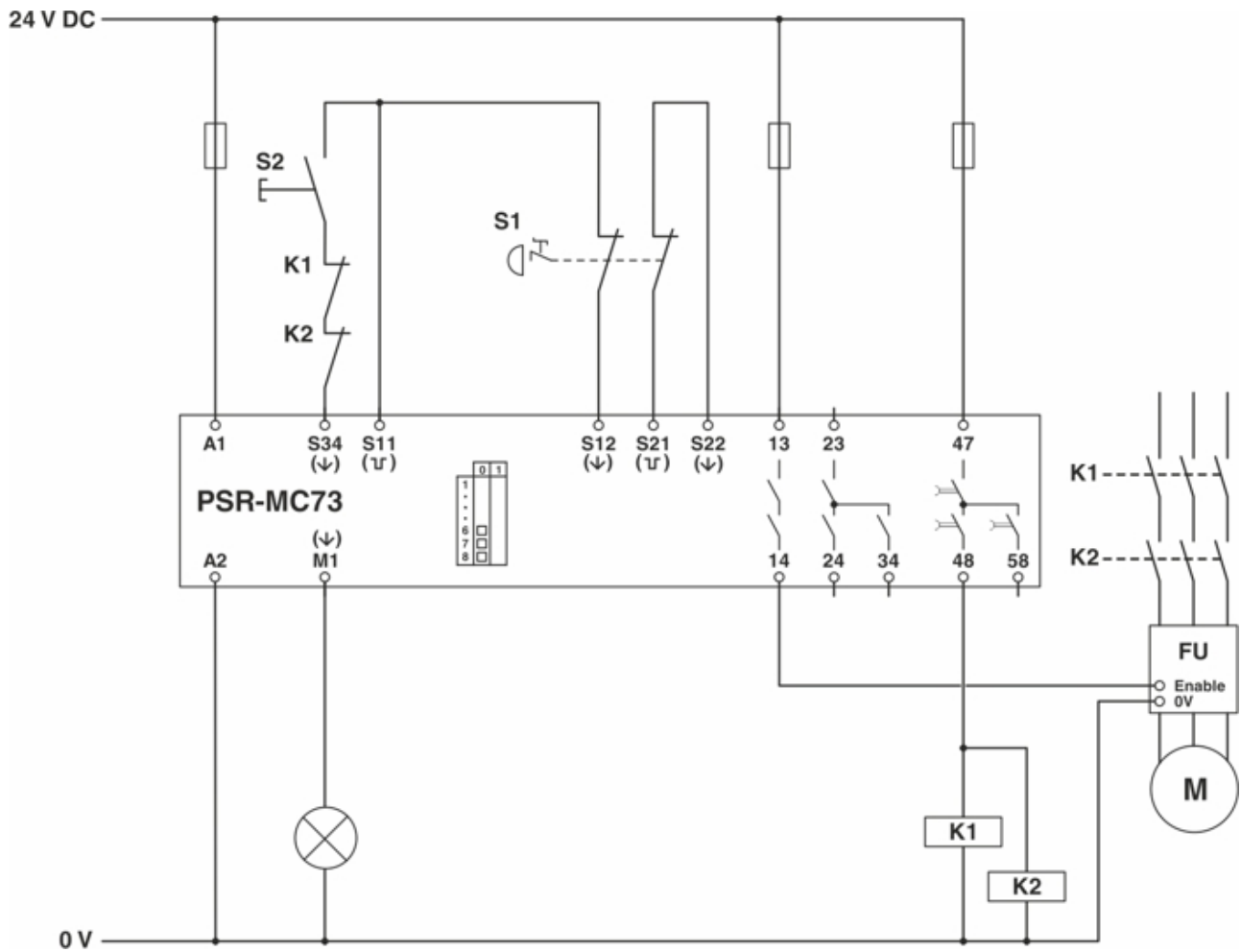

Classifications

eCl@ss

eCl@ss 8.0	27371819
eCl@ss 9.0	27371819

Safety relays - PSR-MC73-5NO-1DO-24DC-SP - 1015526

Classifications

ETIM

ETIM 5.0	EC001449
ETIM 6.0	EC001449
ETIM 7.0	EC001449

Approvals

Approvals

Approvals

UL Listed / cUL Listed / cULus Listed

Ex Approvals

Approval details

UL Listed		http://database.ul.com/cgi-bin/XYV/template/LISEXT/1FRAME/index.htm	FILE E 140324
-----------	--	---	---------------

cUL Listed		http://database.ul.com/cgi-bin/XYV/template/LISEXT/1FRAME/index.htm	FILE E 140324
------------	--	---	---------------

cULus Listed			
--------------	--	--	--

Accessories

Accessories

Coding element

Coding profile - CP-MSTB - 1734634

Coding profile, is inserted into the slot on the plug or inverted header, red insulating material



Safety relays - PSR-MC73-5NO-1DO-24DC-SP - 1015526

Accessories

Coding section - CR-MSTB - 1734401

Coding section, inserted into the recess in the header or the inverted plug, red insulating material



Phoenix Contact 2020 © - all rights reserved
<http://www.phoenixcontact.com>