



BOARD LEVEL COOLING – 10-5607

10-5607 is a square board level heat sink designed to cool BGA and FPGA devices. This heat sink is mounted with nylon push pins with springs. Representative image only.

ORDERING INFORMATION

Part Number	Device Type
10-5607-04G	BGA, FPGA

HEAT SINK DETAILS

Property	Details
Material	Aluminum
Finish	Black Anodize
Device Attachment Options	Push Pin
Thermal Interface Material	HF105 Bergquist Phase Change for All Surfaces

Property	Details
Heat Sink Width (mm)	37.40
Heat Sink Length (mm)	37.40
Heat Sink Height (mm)	10.00
Heat Sink Mounting Direction	Horizontal, Vertical



MECHANICAL & PERFORMANCE

Drawing dimensions are shown in mm, (in)

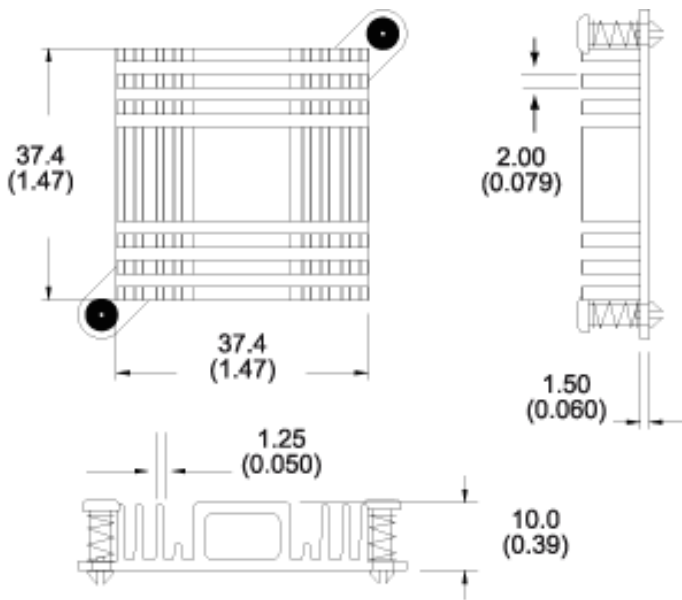

Mounting Details:

