

DATE	SYM	REVISION RECORD	AUTH.	DR.	CK.
10/23/00	-	ISSUED		NT	DG

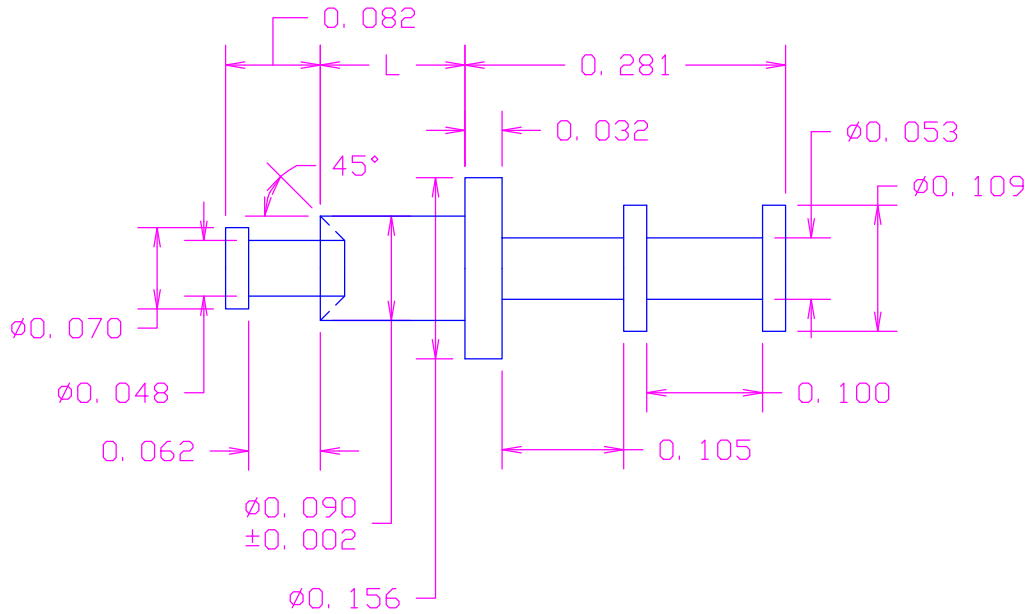

RECOMMENDED MOUNTING HOLE .094 DIA. (342 DRILL)

MATERIAL: BRASS PER ASTM B16,

ALLOY C36000, 1/2 HARD

FINISH: .0003"MIN. SILVER PER QQ-S-365,

TYPE II, GRADE A, WITH NON-CHROMATE

PRESERVATIVE

PART NUMBER:	L:
10-542-1-01	.062
10-542-2-01	.094
10-542-3-01	.125
10-542-4-01	.156
10-542-6-01	.219

ACTUAL SIZE

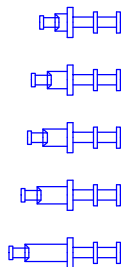

TOLERANCES (EXCEPT AS NOTED)	CONCORD		ELECTRONICS CORPORATION
DECIMAL ± .005	P/N	SCALE	30 GREAT JONES ST. NEW YORK N. Y. 10012
FRACTIONAL ± 1/64	TITLE TERMINAL		
ANGULAR ± 5°	DATE 10/23/00	DRAWING NUMBER 10-542-X-01	