

DATE	SYM	REVISION RECORD	AUTH.	DR.	CK.
2/5/99	-	ISSUED		NT	DG

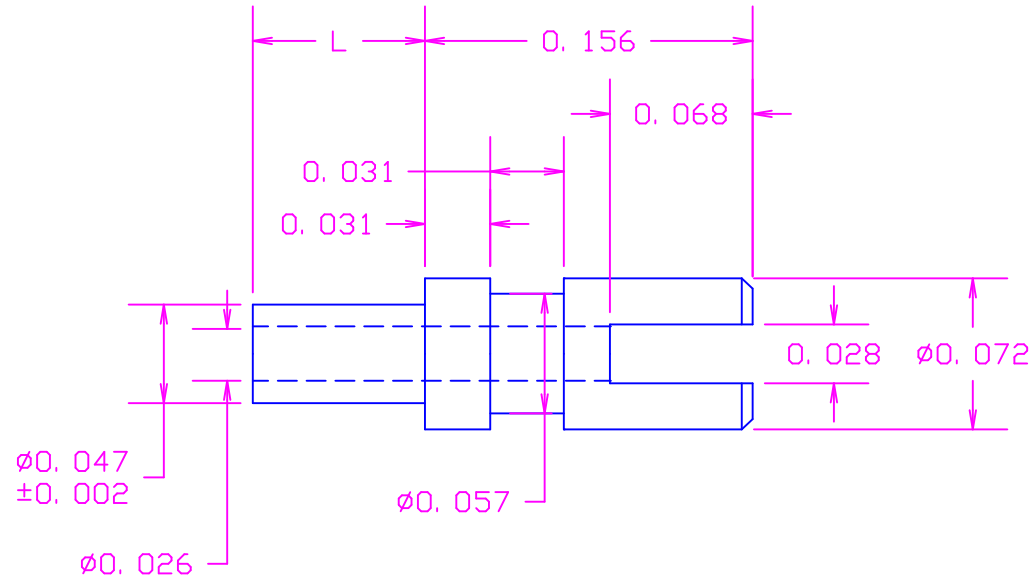

RECOMMENDED MOUNTING HOLE .052 DIA.(#55 DRILL)

MATERIAL: BRASS PER ASTM B16,
ALLOY C 36000, 1/2 HARD

FINISH: .0003"MIN. SILVER PER QQ-S-365,
TYPE II, GRADE A WITH NON-CHROMATE
PRESERVATIVE

PART NUMBER:	L	T
10-414-11	.035	1/64
10-414-1	.051	1/32
10-414-2	.082	1/16
10-414-3	.113	3/32
10-414-4	.145	1/8
10-414-6	.207	3/16
10-414-8	.270	1/4

ACTUAL SIZE



TOLERANCES	CONCORD ELECTRONICS CORPORATION		
DECIMAL ± .005	P/N	SCALE	30 GREAT JONES ST. NEW YORK N. Y. 10012
FRACTIONAL ± 1/64	TITLE TERMINAL		
± 5°	DATE 6-25-98	DRAWING NUMBER 10-414-X-01	