

MATED WITH: PASSEND ZU:	LOC A1	DIST -	REVISIONS AENDERUNGEN				DATE	DWN	APVD
-			P	LTR	DESCRIPTION BESCHREIBUNG				
PROJEKT NR.:	-		A1	neu gezeichnet	Eg00-1705-01	07.06.01	SR	SM	

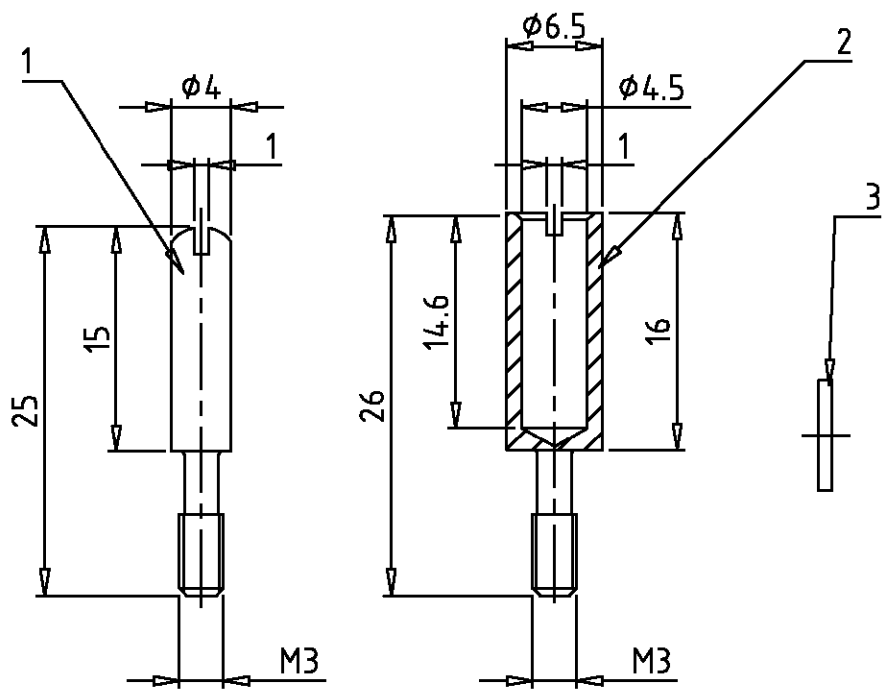

QUANTITY / STÜCK	DESCRIPTION / BENENNUNG	MATERIAL	SURFACE/COLOR	POS.	NOTE / BEMERKUNG
1	Kodieranleitung mit Kodierschema				1 x pro Verpackungseinheit
64	Federscheibe A3	Stahl	verzinkt	3	in Poly-Beutel verpackt
32	Kodierbuchse $\phi 4.5$ mm	Stahl	vernickelt	2	in Poly-Beutel verpackt
32	Kodierstift $\phi 4$ mm	Stahl	vernickelt	1	in Poly-Beutel verpackt
1-1 ORDERING NO. / BESTELLNUMMER					
Kodierset COS16					

THIS DRAWING IS UNPUBLISHED. VERTRAULICHE UNVERÖFFENTLICHTE ZEICHNUNG. ALL RIGHTS RESERVED. ALLE RECHTE VORBEHALTEN. BY AMP INCORPORATED. COPYRIGHT 1998.

DIMENSIONS: DIMENSIONEN: mm TOLERANCES UNLESS OTHERWISE SPECIFIED: ALLGEMEINTOLERANZEN ISO 8015 ISO 2768 - mH - E DIN 16901 - 140 ANGLES / WINKEL # 	DWN Schneider 07.06.01	MATERIAL -	FINISH OBERFLAECHE/FARBE -			
	CHK Schweiger 07.06.01	HTS Elektrotechnik 53819 Neunkirchen, Germany				
	APVD -					
	PRODUCT SPEC PRODUKTSPEZ. -	NAME Coding set COS16 Kodierset COS16	SIZE A4	CAGE CODE 00779	DRAWING NO ZEICHNUNGS-NR. C= 1106103	RESTRICTED TO NUR FUER -
APPLICATION SPEC VERARBEITUNGSSPEZ. -	WEIGHT GEWICHT -	/KUNDENZEICHNUNG		MASSTAB 2:1	BLATT 1 OF VON 1	A1