



DIN Power female low profile - NFF



General information

Design	IEC 60603-2	types: F low profile female
No. of contacts	max. 48	
Contact spacing	5,08 mm between contacts	3,81 mm between rows
Test voltage	1550V contact/contact	2500V contact/ground
Contact resistance	max. 15mOhm	
Insulation resistance	min. 10 ¹⁰ Ohm	
Working current	6A at 20°C (see derating diagram) for unmounted connector, limitations may occur due to PCB material	
Temperature range	-55°C ... +125°C -40°C ... +105°C for press-in connectors (due to limitations of PCB-material)	
Termination technology	press-in, solder pins	
Clearance	min. 1,6 mm	
Creepage	min. 3,0 mm	
Insertion and withdrawal force	32-pole max. 50N 48-pole max. 75N	
Mating cycles	- PL 1 acc. to IEC 60603-2 => 500 mating cycles - PL 2 acc. to IEC 60603-2 => 400 mating cycles - PL 3 acc. to IEC 60 603-2 => 50 mating cycles	
UL file	-	
RoHS - compliant	Yes	
Leadfree	Yes	
Hot plugging	No	

Insulator material

Material	PC (thermoplastics, glass fiber reinforcement 20%)
Color	RAL 7032 (grey)
UL classification	UL 94-V0
Material group acc. IEC 60664-1	IIIa (175 ≤ CTI < 400)
NFF classification	I2, F1

Contact material

Contact material	Copper alloy
Plating termination zone	Sn over Ni for solder, Ni for press-in
Plating contact zone	Au over Pd/Ni over Ni

Derating diagram acc. to IEC 60512-5 (Current carrying capacity)

The current carrying capacity is limited by maximum temperature of materials for inserts and contacts including terminals.

The current capacity curve is valid for continuous, non interrupted current loaded contacts of connectors when simultaneous power on all contacts is given, without exceeding the maximum temperature.

Control and test procedures according to DIN IEC 60512-5

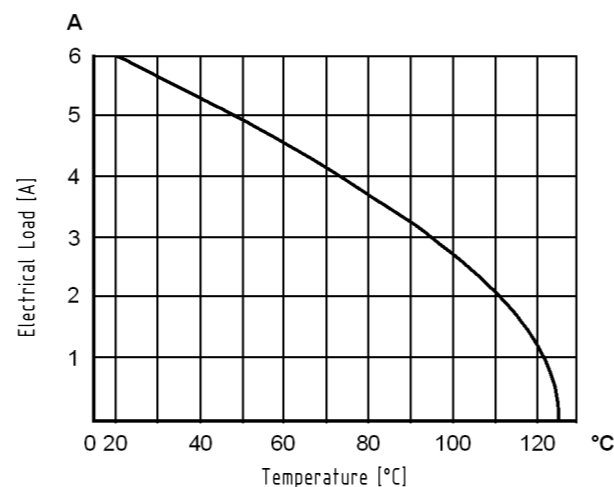

Recommended configuration of plated through holes for press-in termination

In addition to the hot-air-level (HAL), other PCB surfaces are getting more important. Due to their different properties - such as mechanical strength and coefficient of friction - we recommend the following configuration of PCB through holes.

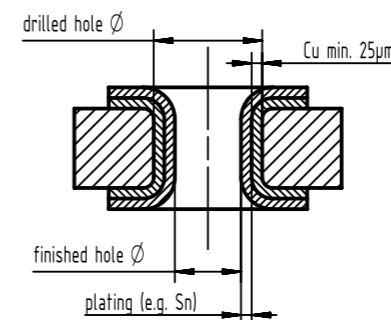

PCB Type	Plating	Drilled hole Ø	Plated hole Ø
Tin plated PCB (HAL) acc. to EN 60352-5	Sn	1,15±0,025 mm	max. 15 µm
			0,94 - 1,09 mm
Chemical tin plated PCB	Sn	1,15±0,025 mm	min. 0,8µm
			1,00 - 1,10 mm
Gold /Nickel plated PCB	Ni	1,15±0,025 mm	3 - 7 µm
	Au		0,05 - 0,12 µm
Silver plated PCB	Ag	1,15±0,025 mm	0,1 - 0,3 µm
			1,00 - 1,10 mm
Copper plated PCB (OSP)		1,15±0,025 mm	1,00 - 1,10 mm
			1,00 - 1,10 mm

Assembly instructions

It is highly recommended to use HARTING press-in tools to ensure a reliable press-in process. Please refer to the catalogue for tools, machines and further information about the press-in process.

Soldering instructions

The connectors should be protected when being soldered in a dip, flow or film soldering baths. Otherwise, they might become contaminated as a result of soldering operations or deformed as a result of overheating.

(1) For prototypes and short runs protect the connectors with an industrial adhesive tape, e.g. Tesaband 4331 (www.tesa.de). Cover the underside of the connector moulding and the adjacent parts of the pcb as well as the open sides of the connector. This will prevent heat and gases of the soldering apparatus from damaging the connector. About 140 + 5 mm of the tape should suffice.

(2) For large series a jig is recommended. Its protective cover with a fast action mechanical locking device shields the connectors from gas and heat generated by the soldering apparatus. As an additional protection a foil can be used for covering the parts that should not be soldered.

Cross section of solder terminations

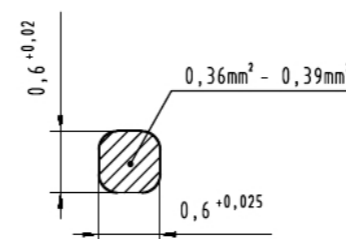

All Dimensions in mm Original Size DIN A3		Scale 1:1	Free size tol.	Ref.
All rights reserved Department EL PD		Created by STORCK	Inspected by LEHNERT	Standardisation HOFFMANN
HARTING Electronics GmbH D-32339 Espelkamp		Title DIN Power female low profile - NFF	Date 2019-11-27	State Final Release
Type DS		Number 09062120001		Doc-Key / ECM-Nr. 100580659/UGD/000/B 500000161564
		Rev. B	Page 1/1	