

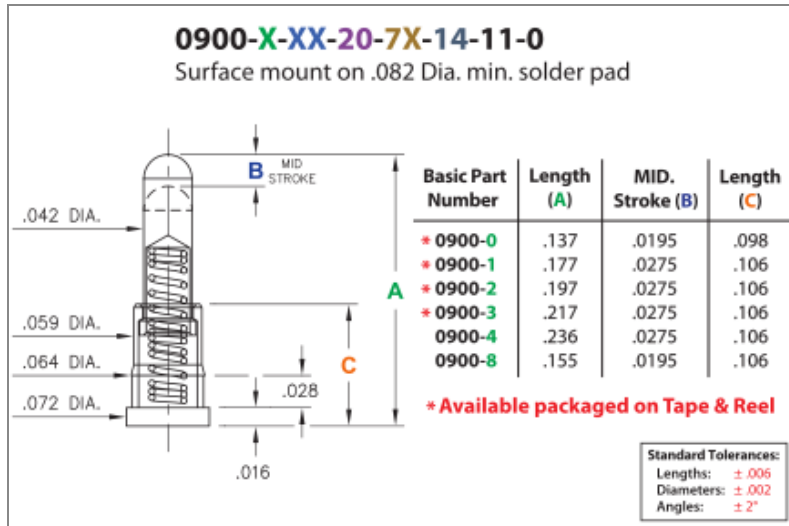

PRODUCT NUMBER: 0900-1-57-20-75-14-11-0

www.mill-max.com
DATA SHEET



0900-1-57-20-75-14-11-0 SPECIFICATIONS

General Info	
Description¹:	Surface Mount Spring-Loaded Pin
Mounting Feature:	Surface Mount
Initial Height:	.177" (4,496mm)
Stroke:	.055" (1,397mm)
Packaging:	Vertically on Tape & Reel
RoHS²:	Yes
Product Lifecycle³:	Active

Materials
Shell Material⁴: Brass Alloy
Shell Plating⁵: 20 μ" Gold over Nickel
Spring Plating⁶: 10 μ" Gold over Nickel

Technical Specs	
Durability:	100,000 to 1,000,000 Cycles @ Mid-Stroke
Operating Temperature Range⁷:	-55/+125° C
Current Rating⁸:	See Spring Specifications Below
Contact Resistance⁹:	See Spring Specifications Below
Shock¹⁰:	No Elect. Discontinuity > 1μs @ 50g
Vibration¹¹:	No Elect. Discontinuity > 1μs @ 10-2000HZ, 20 G

NOTES:

- Standard Tolerances:
Lengths $\pm .0006''$ (0,15)
Diameters: $\pm .002''$ (0,051)
Angles: $\pm 2^\circ$
- Mill-Max products labeled with the RoHS symbol are compliant with all three ROHS Directives. All of our products previously described as RoHS (2002/95/EC) and RoHS-2 (2011/65/EC) are also compliant with RoHS-3 (2015/863/EU).
- Part is Active and in Production, No Scheduled Obsolescence
- Brass Alloy 360 per ASTM B 16, or 385 per ASTM B455
- GOLD per ASTM B 488, Type 1 (99.7% min. gold), Code C (130-200 HK {Knoop hardness}); NICKEL per ASTM B 689, Type 2 (Bright)
- GOLD per ASTM B 488, Type 1 (99.7% min. gold), Code C (130-200 HK {Knoop hardness}), NICKEL per ASTM B 689, Type 2 (Bright)
- Storage per IEC 60512-11-(4,9,10,12) and peak operating temperature per IEC 60512-5-2, Test 5b
- Per IEC 60512-5-2; Current Carrying Capacity; Current Derating
- Per EIA-364-23C: Low Level Contact Resistance.
- Per IEC 60512-6-3: Test 6c: Shock
- Per IEC 60512-6-4: Test 6d: Vibration (sinusoidal)

ADDITIONAL PARTS, PACKAGING, & ASSEMBLY INFO

0900-0-15-20-76-14-11-0

Surface mount on .082 Dia. min. solder pad. Also available on 16mm wide X 8mm pitch carrier tape; 2,000 parts per 13" reel
Order as: 0900-0-57-20-76-14-11-0

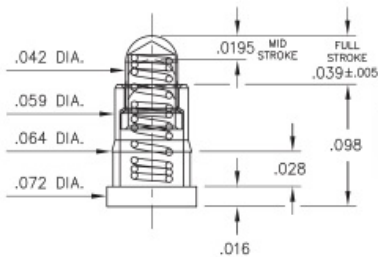

Standard Tolerances:
Lengths: $\pm .0006$
Diameters: $\pm .002$
Angles: $\pm 2^\circ$

0900-1-15-20-7X-14-11-0

Surface mount on .082 Dia. min. solder pad, Also available on 16mm wide X 8mm pitch carrier tape: 1,500 parts per 13" reel
Order as: 0900-1-57-20-7X-14-11-0

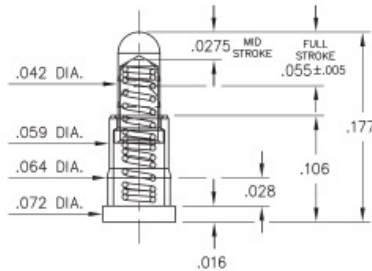

Standard Tolerances:
Lengths: $\pm .0006$
Diameters: $\pm .002$
Angles: $\pm 2^\circ$

0900-1-59-20-7X-14-11-0

Special Tape & Reel packaging option: **Plunger side down**
Available on 16mm wide X 8mm pitch carrier tape: 1,700 parts per 13" reel
Pick and place solution for through-hole applications

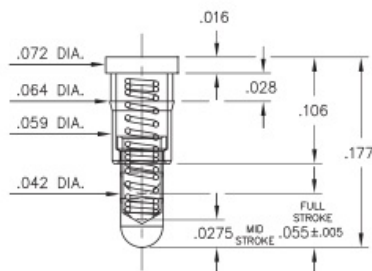

Standard Tolerances:
Lengths: $\pm .0006$
Diameters: $\pm .002$
Angles: $\pm 2^\circ$

0900-2-15-20-7X-14-11-0

Surface mount on .082 Dia. min. solder pad, Also available on 24mm wide X 8mm pitch carrier tape: 1,100 parts per 13" reel
Order as: 0900-2-57-20-7X-14-11-0

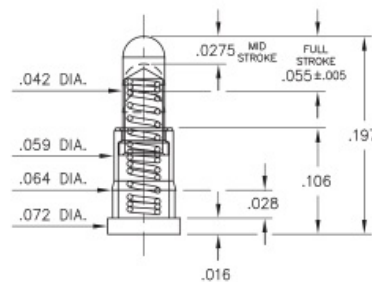

Standard Tolerances:
Lengths: $\pm .0006$
Diameters: $\pm .002$
Angles: $\pm 2^\circ$

0900-3-15-20-7X-14-11-0

Surface mount on .082 Dia. min. solder pad, Also available on 24mm wide X 8mm pitch carrier tape: 1,100 parts per 13" reel
 Order as: 0900-3-57-20-7X-14-11-0

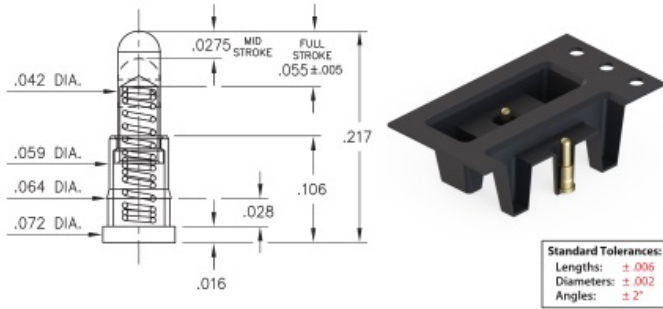

Standard Tolerances:
 Lengths: ± .006
 Diameters: ± .002
 Angles: ± 2°

0900-4-15-20-7X-14-11-0

Standard stroke
 Surface mount on .082 Dia. min. solder pad

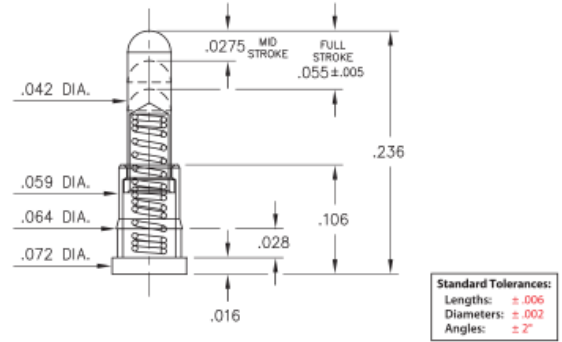

Standard Tolerances:
 Lengths: ± .006
 Diameters: ± .002
 Angles: ± 2°

0900-8-15-20-76-14-11-0

Short stroke
 Surface mount on .082 Dia. min. solder pad

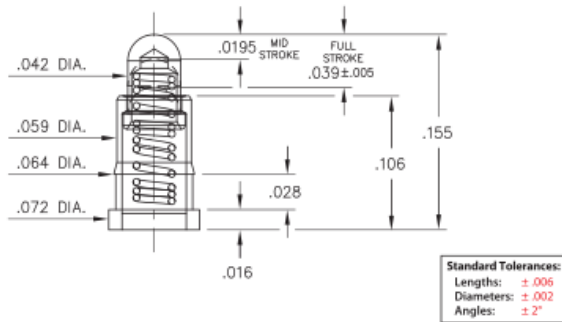

Standard Tolerances:
 Lengths: ± .006
 Diameters: ± .002
 Angles: ± 2°

SPRING:

#75 SPRING STANDARD FORCE SPRING	Full Stroke Capability : .055" ± .005" [1,4 ± 0,127]
Spring Material : Beryllium Copper Alloy 172	Force @ Mid. Stroke : 60 g ± 20 g
Mid. Stroke : .0275" [0,7]	Initial Force (Pre-Load) : 10 g

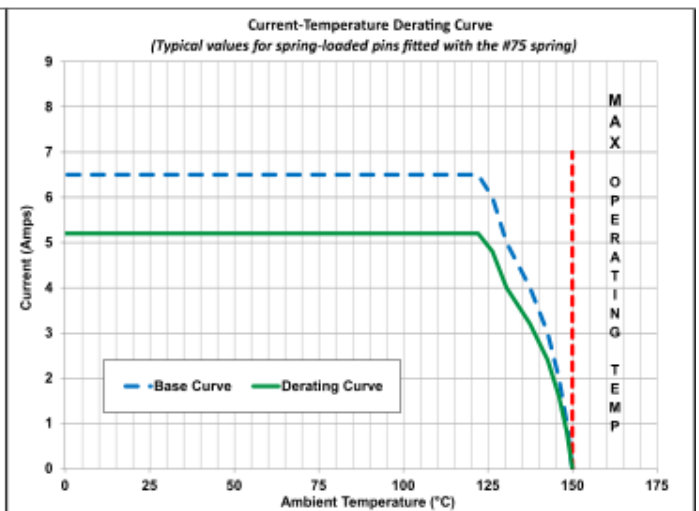
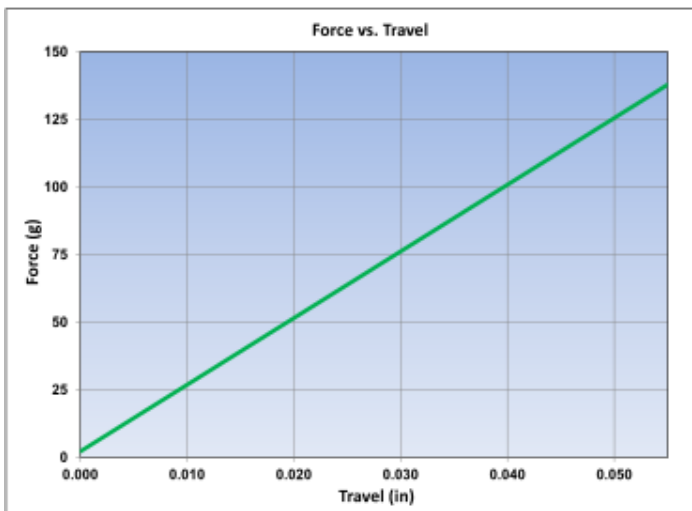

The stroke, force and current rating values are measured using spring pins with an internal construction per the design specification. Individual spring pin performance may vary from these values based on design differences.

Material	Beryllium Copper	Grams Force	60
----------	------------------	-------------	----

Max Stroke	0.06	Maximum Current	6.5A @ 30° C Temp. Rise
Maximum Operating Temp @ Max Current	120.00° C	20% De-rated Maximum Current	5.20A
Contact Resistance	20.00mΩ Max		

ADDITIONAL NOTES AND SPECIFICATIONS

In the interest of improved design, quality and performance , Mill-Max reserves the right to make changes in its specifications without prior notice. Specifications and tolerances are provided wherever possible. The tolerance on dimensions of critical to function features is typically held tighter than the stated standard tolerances, such as press-fits, holes and lengths affecting the coplanarity of SMT products. Due to the wide variety of interconnects Mill-Max offers, the specific tolerances vary from product to product. If you need information regarding the tolerance of a particular part, please contact Technical Services.

RELATED LINKS AND DOCUMENTS

Product Change Notice: (https://www.mill-max.com/sites/default/files/external/assets/2019-10/0900-x-pcn-19-1030a_0.pdf)

Engineering Notebook: (<https://www.mill-max.com/engineering-notebooks/introduction-to-spring-loaded-pogo-pins-connectors>)

Environmental Compliance: (<https://www.mill-max.com/rohs>)