

Product description **Snap-In IP40 male panel mount connector, Contacts: 4, shielding is not possible, dip-solder, IP40**  
 Area **Snap-In IP40 series 719 · 709**  
 Order number **09 9765 20 04**

Illustration	Scale drawing	Contact arrangement															
		<table border="1" style="margin-left: auto; margin-right: auto;"> <thead> <tr> <th></th> <th>X</th> <th>Y</th> </tr> </thead> <tbody> <tr> <td>1</td> <td>1,06</td> <td>-1,06</td> </tr> <tr> <td>2</td> <td>1,06</td> <td>1,06</td> </tr> <tr> <td>3</td> <td>-1,06</td> <td>1,06</td> </tr> <tr> <td>4</td> <td>-1,06</td> <td>-1,06</td> </tr> </tbody> </table>		X	Y	1	1,06	-1,06	2	1,06	1,06	3	-1,06	1,06	4	-1,06	-1,06
	X	Y															
1	1,06	-1,06															
2	1,06	1,06															
3	-1,06	1,06															
4	-1,06	-1,06															

You can find the component part drawing and assembly instructions on the next page.

## Technical data

### General values

Connector design	male panel mount connector
Connector locking system	snap
Termination	dip-solder
Upper limit temperature	70 °C
Lower limit temperature	- 25 °C
Customs tariff number	85369010
Packaging Unit	1

### Electrical values

Rated current (40 °C)	3 A
Rated voltage	60 V
Rated impulse voltage	800 V
Pollution degree	1
Overvoltage category	II
Insulating material group	III
Insulation resistance	≥ 10 <sup>10</sup> Ω
EMC compliance	shielding is not possible
Degree of protection	IP40
Mechanical operation	> 100 Mating cycles

### Material

Contact material	CuZn (brass)
Contact plating	Au (gold)
Contact body material	PA
Housing material	PA

Product description Snap-In IP40 male panel mount connector, Contacts: 4, shielding is not possible, dip-solder, IP40

Area Snap-In IP40 series 719 · 709  
Order number 09 9765 20 04

### Component part drawing

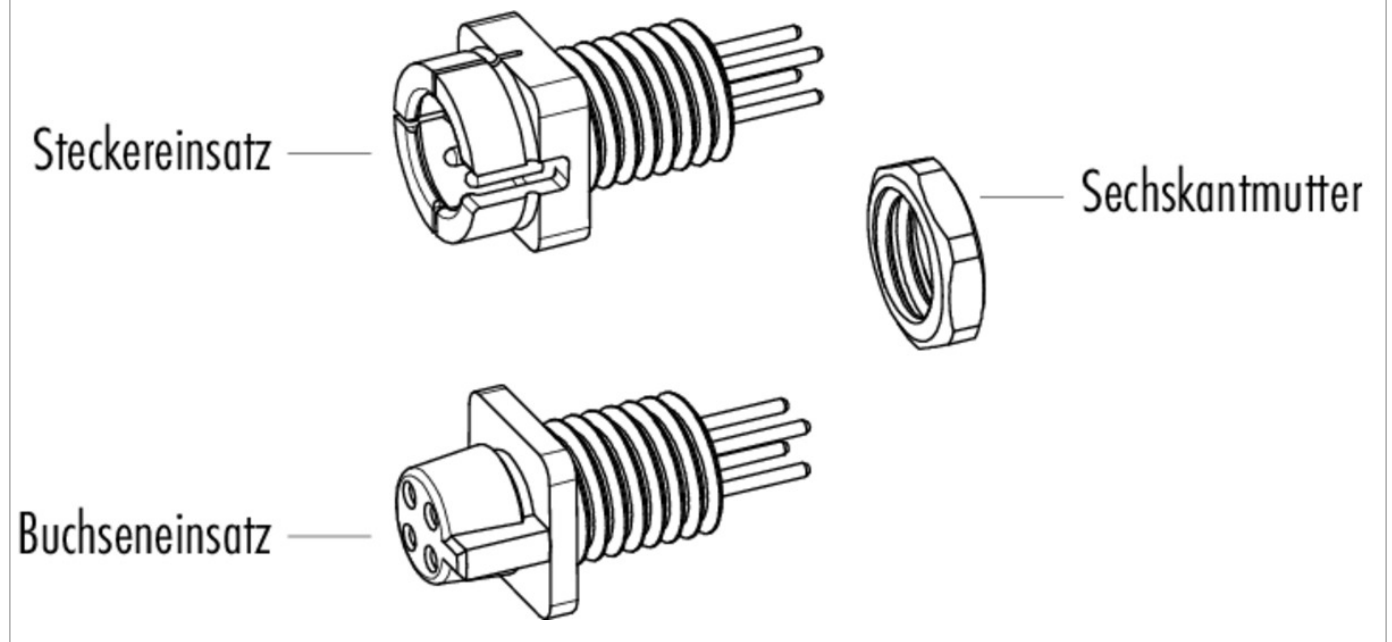

### Assembly instructions / Panel cut-out

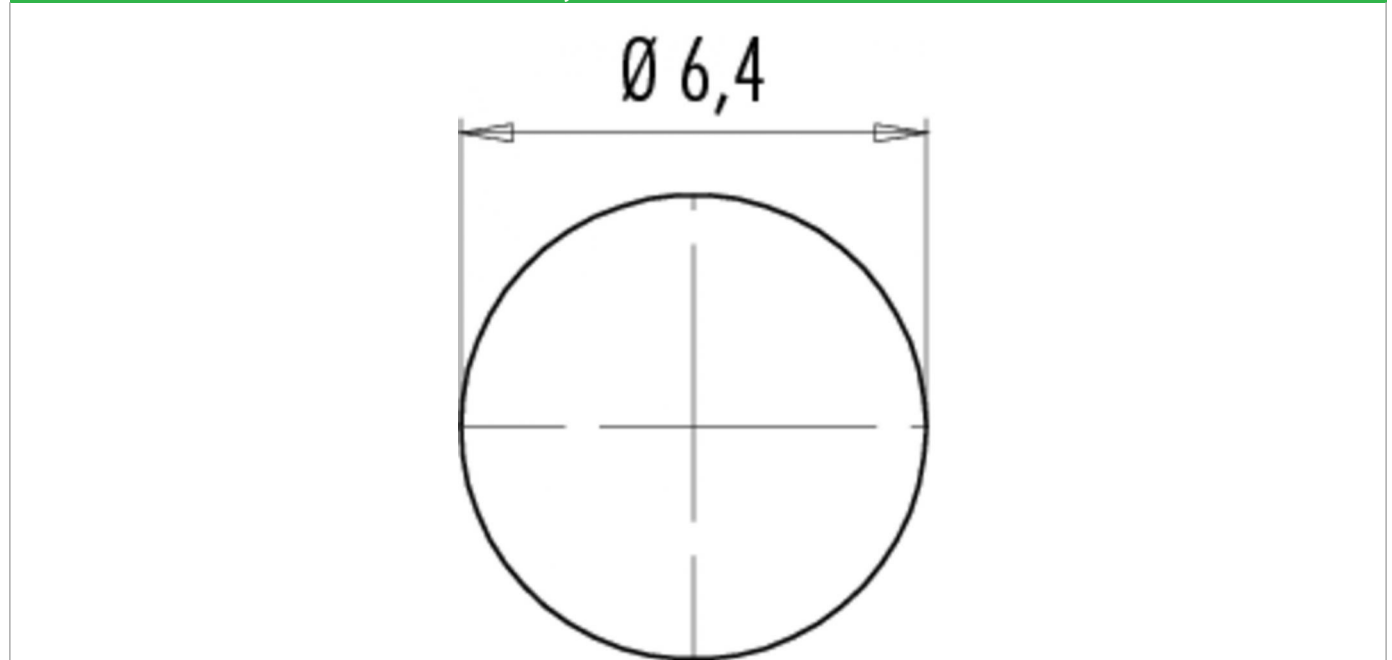

Product description	<b>Snap-In IP40 male panel mount connector, Contacts: 4, shielding is not possible, dip-solder, IP40</b>
Area	<b>Snap-In IP40 series 719 · 709</b>
Order number	<b>09 9765 20 04</b>

## Security notices

The connectors are designed for use in plant, control system and electrical equipment. The end user is responsible for checking whether the connectors are suitable for use in other applications.