

DRAWING NUMBER:	09-9111-1-XXXX
PRODUCT GROUP:	PANEL JACKS AND TERMINALS
SUB-GROUP:	PANEL JACKS AND TERMINALS - THREAD MOUNT
DESCRIPTION:	PANEL JACK - METAL THREAD

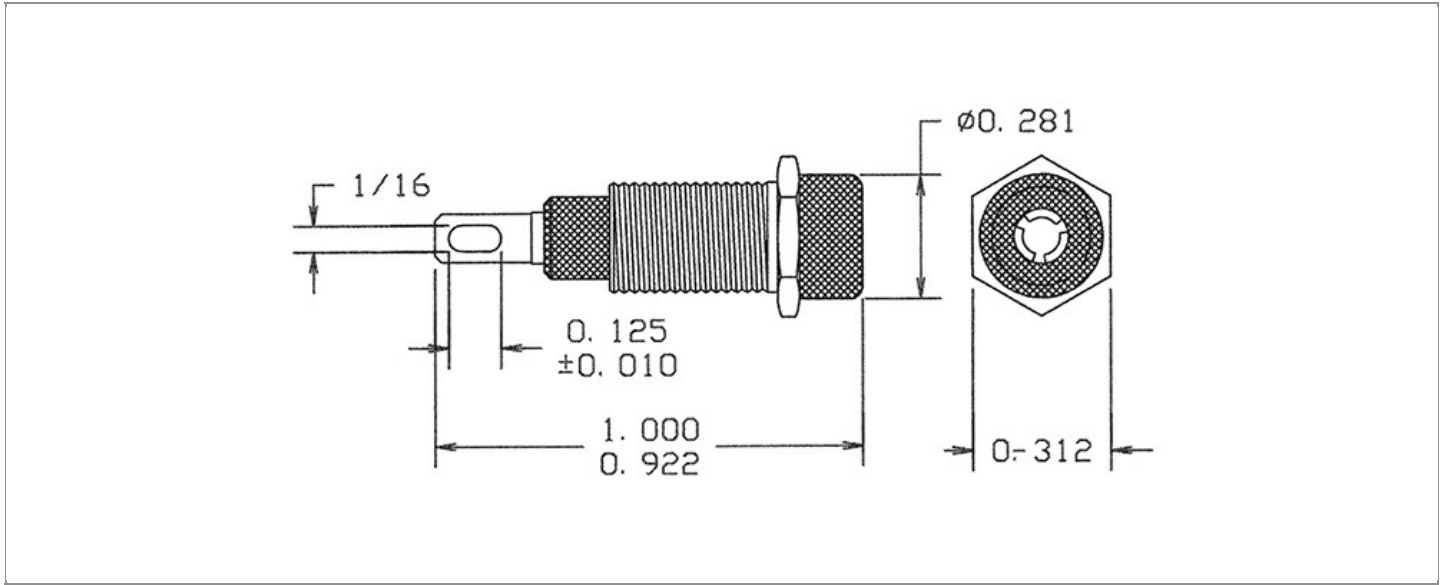

ACCEPTS PIN / PLUG / JACK SIZE	MIN. HOLE DEPTH	MOUNTING ORIENTATION	BOARD / PANEL MOUNTING METHOD
0.080" ± 0.001	0.420"	VERTICAL	THREAD MOUNT (1/4-32 NUT)
MOUNTING HOLE SIZE	BOARD / PANEL THICKNESS	FEED THRU COMBINATION	OVERALL LENGTH
0.257" ± 0.002	UP TO 3/16"	JACK/EYELET	0.922"

PART NO. STRUCTURE:

09-9111	-	1	-	XX	XX
PART SERIES		DIMENSION		FINISH	INSULATION COLOR

MATERIAL OPTIONS:

09-9111-1-XXXX

COMPONENT	MATERIAL	MATERIAL AND SPECIFICATION
BODY	BRASS	BRASS PER ASTM B16, ALLOY C36000, 1/2 HARD
SPRING (CAGE)	BERYLLIUM COPPER	BERYLLIUM COPPER PER ASTM B194, ALLOY C17200
INSULATION*	NYLON	NYLON PER ASTM D4066
BASE/METAL SLEEVE	BRASS	BRASS PER ASTM B16, ALLOY C36000, 1/2 HARD
NUT	BRASS	BRASS PER ASTM B16, ALLOY C36000, 1/2 HARD
WASHER	PHOSPHOR BRONZE	PHOSPHOR BRONZE PER ASTM B139/B103, ALLOY C51000
LUG	N/A	N/A

*For Insulation color, please see INSULATION COLOR OPTIONS on Page 2

FINISH - PLATING OPTIONS:

09-9111-1-XXXX

FINISH CODE	COMPONENT	FINISH	FINISH AND SPECIFICATION
044	BODY	BRIGHT ELECTRO-TIN	0.000200"MIN. BRIGHT ELECTRO-TIN PER ASTM B545 OVER 0.000100"MIN. NICKEL PER SAE-AMS-QQ-N-290, CLASS 2
	SPRING (CAGE)	BRIGHT ELECTRO-TIN	0.000200"MIN. BRIGHT ELECTRO-TIN PER ASTM B545 OVER 0.000100"MIN. NICKEL PER SAE-AMS-QQ-N-290, CLASS 2
	BASE/METAL SLEEVE	NICKEL	0.000100"MIN. NICKEL PER SAE-AMS-QQ-N-290, CLASS 2
	NUT	NICKEL	0.000100"MIN. NICKEL PER SAE-AMS-QQ-N-290, CLASS 2
	WASHER	NICKEL	0.000100"MIN. NICKEL PER SAE-AMS-QQ-N-290, CLASS 2
	LUG	N/A	N/A

INSULATION COLOR OPTIONS:

09-9111-1-XXXX

INSULATION COLOR	BLACK	BROWN	RED	ORANGE	YELLOW	GREEN	BLUE	VIOLET	GRAY	WHITE
COLOR CODE NO.	10	11	12	13	14	15	16	17	18	19

TOLERANCES:*

DECIMAL	FRACTIONAL	ANGULAR	DRAWING ORIGATION DATE	LAST MODIFICATION DATE
± 0.010	± 1/64	N/A	10/9/1996	1/1/2017

*All dimensions are in inches.

RoHS COMPLIANCE:

09-9111-1-044XX

PART NUMBER	RoHS COMPLIANT
09-9111-1-04410	YES
09-9111-1-04411	YES
09-9111-1-04412	YES
09-9111-1-04413	YES
09-9111-1-04414	YES
09-9111-1-04415	YES
09-9111-1-04416	YES
09-9111-1-04417	YES
09-9111-1-04418	YES
09-9111-1-04419	YES

MILITARY REFERENCE SPECIFICATIONS:

09-9111-1-044XX

PART NUMBER	MIL SPECIFICATION	MIL PART NUMBER
09-9111-1-04410	N/A	N/A
09-9111-1-04411	N/A	N/A
09-9111-1-04412	N/A	N/A
09-9111-1-04413	N/A	N/A
09-9111-1-04414	N/A	N/A
09-9111-1-04415	N/A	N/A
09-9111-1-04416	N/A	N/A
09-9111-1-04417	N/A	N/A
09-9111-1-04418	N/A	N/A
09-9111-1-04419	N/A	N/A

NOTES:

DATASHEET NOTES

NUT PART NO.: 701-7414-02, WASHER PART NO.: 701-7705-02.

INSTRUCTION NOTES

SUPPLIED WITH NICKEL PLATED BRASS HEX NUT (1/4-32 x 11/32" x 3/32") AND NICKEL PLATED PHOSPHOR BRONZE 1/4 INTERNAL TOOTH LOCKWASHER.