

# P.C. JACK-CLOSED ENTRY-SWAGE MOUNT

## 09-9067-X-XX P.C. JACK FOR .060, .061 AND .062 PINS\*

BASIC PART NO. FINISH

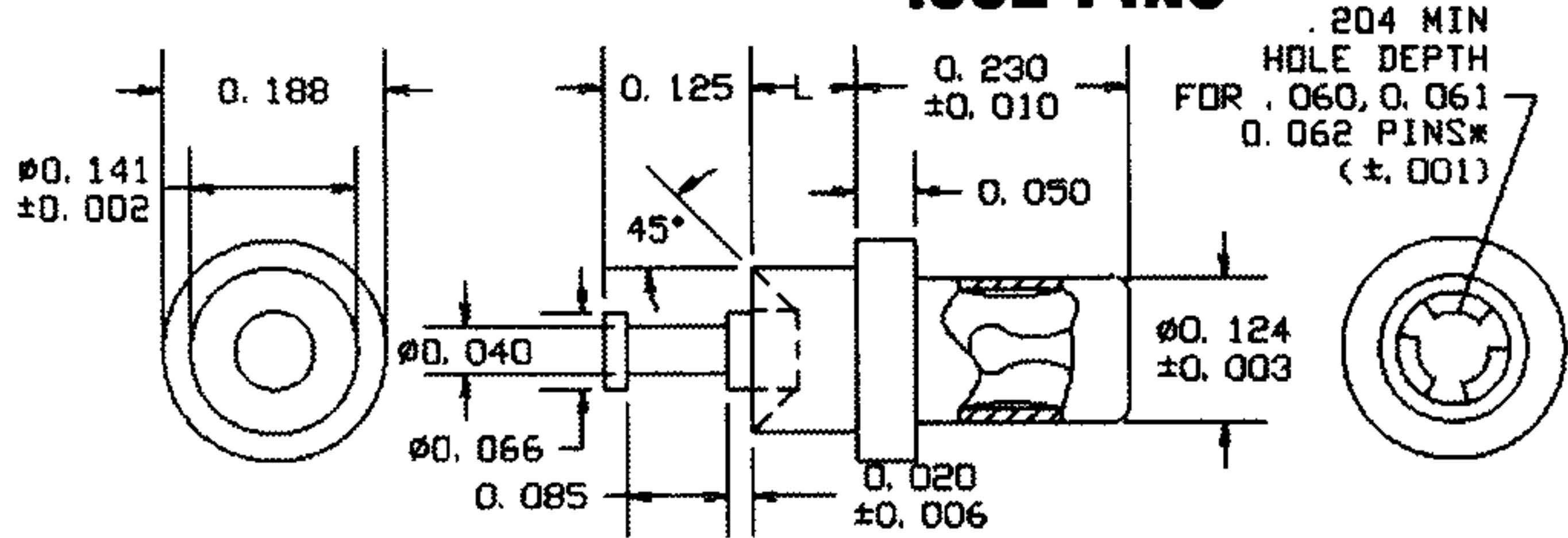

\*USE ONE PIN SIZE ONLY-NOT RECOMMENDED FOR SMALLER PIN USE AFTER LARGER PIN HAS BEEN USED.

ACCEPTS .060, .061 AND .062 PINS

PART NO.	L	BOARD THK.
09-9067-1	.058	1/32
09-9067-2	.089	1/16
09-9067-3	.120	3/32
09-9067-4	.151	1/8
09-9067-6	.214	3/16

INSTALLATION TOOLS

ANVIL	PUNCH
TA188-124-50	TP141-T66

RECOMMENDED MOUNTING HOLE .144±.002/-.001(#27 DRILL)

## 09-9019-X-XX DOUBLE ENDED P.C. JACK FOR .025 AND .040 PINS

BASIC PART NO. FINISH

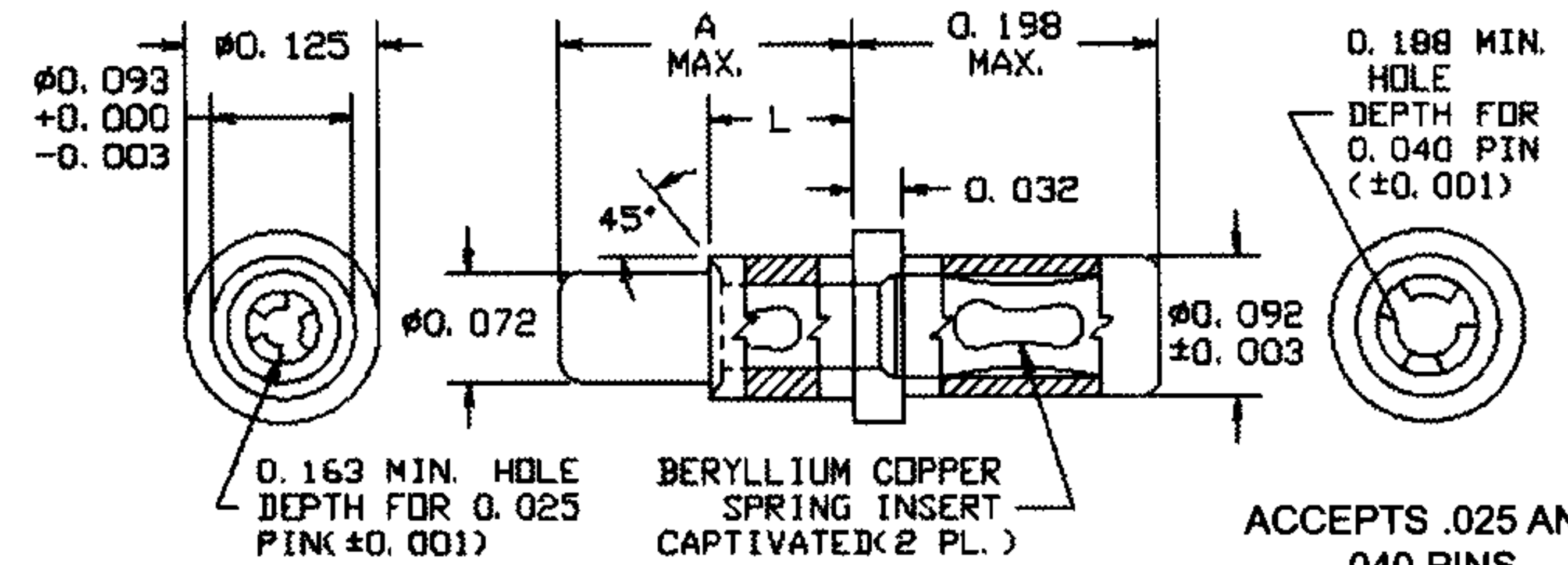

ACCEPTS .025 AND .040 PINS

PART NO.	L	A	BOARD THK.
09-9019-2	.094	.191	1/16
09-9019-3	.125	.191	3/32
09-9019-4	.156	.191	1/8
09-9019-6	.219	.253	3/16

INSTALLATION TOOLS

ANVIL	PUNCH
TA125-94-23	TP93-T73

RECOMMENDED MOUNTING HOLE .094±.002/-.001(#42 DRILL)

## 09-9042-X-XX P.C. JACK FOR .080 PIN

BASIC PART NO. FINISH

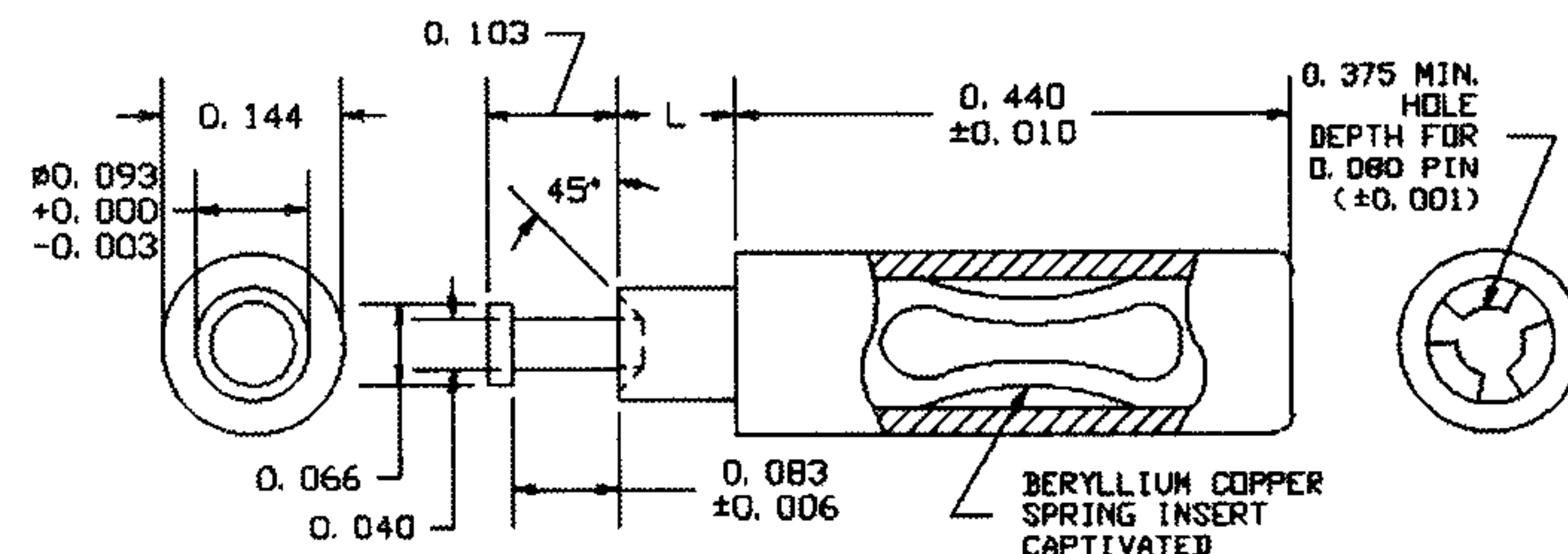

ACCEPTS .080 PIN

PART NO.	L	BOARD THK.
09-9042-1	.062	1/32
09-9042-2	.094	1/16
09-9042-3	.125	3/32
09-9042-4	.156	1/8
09-9042-6	.219	3/16

INSTALLATION TOOLS

ANVIL	PUNCH
TA144-430	TP93-T66

RECOMMENDED MOUNTING HOLE .094±.002/-.001(#42 DRILL)

## 09-9022-X-XX DOUBLE ENDED P.C. JACK FOR .025 PIN, BOTH ENDS

BASIC PART NO. FINISH

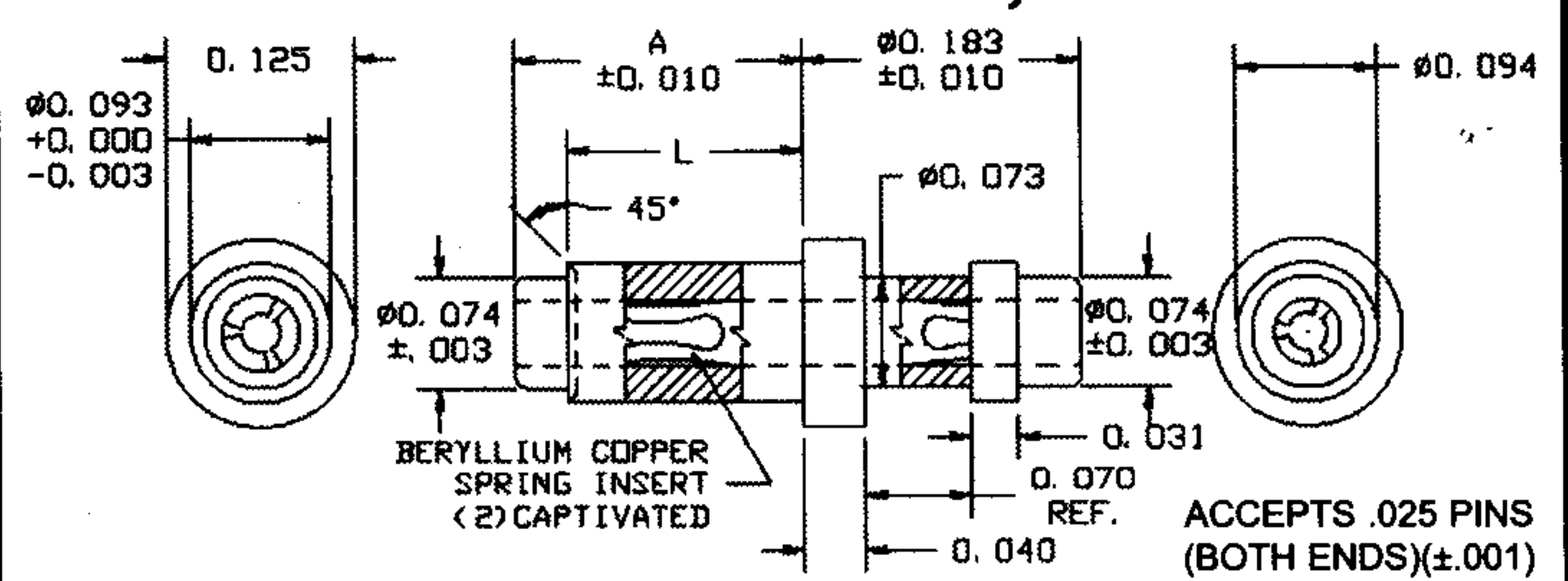

ACCEPTS .025 PINS (BOTH ENDS)(±.001)

PART NO.	L	A	BOARD THK.
09-9022-2	.094	.129	1/16
09-9022-3	.125	.160	3/32
09-9022-4	.156	.191	1/8
09-9022-6	.219	.254	3/16

INSTALLATION TOOLS

ANVIL	PUNCH
TA125-94-23	TP93-T73

RECOMMENDED MOUNTING HOLE .094±.002/-.001(#42 DRILL)

## 09-9003-X-XX P.C. JACK SLOTTED FOR .040 PIN

BASIC PART NO. FINISH

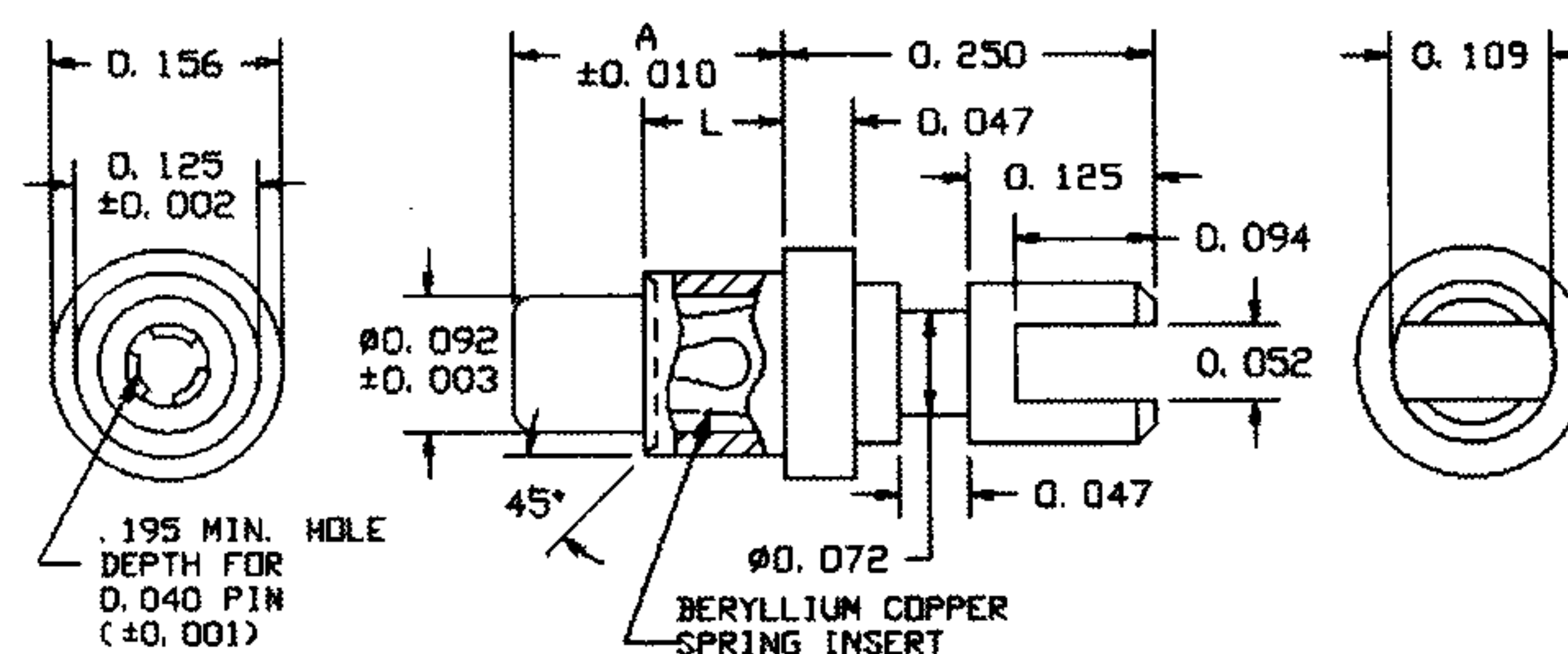

ACCEPTS .040 PIN

PART NO.	L	A	BOARD THK.
09-9003-2	.094	.182	1/16
09-9003-3	.125	.182	3/32
09-9003-4	.156	.182	1/8
09-9003-6	.219	.223	3/16

INSTALLATION TOOLS

ANVIL	PUNCH
TA09-9003	TP125-93

RECOMMENDED MOUNTING HOLE .129±.002(#30 DRILL)

## 09-9007-X-XX DOUBLE ENDED P.C. JACK FOR .040 PIN BOTH ENDS

BASIC PART NO. FINISH

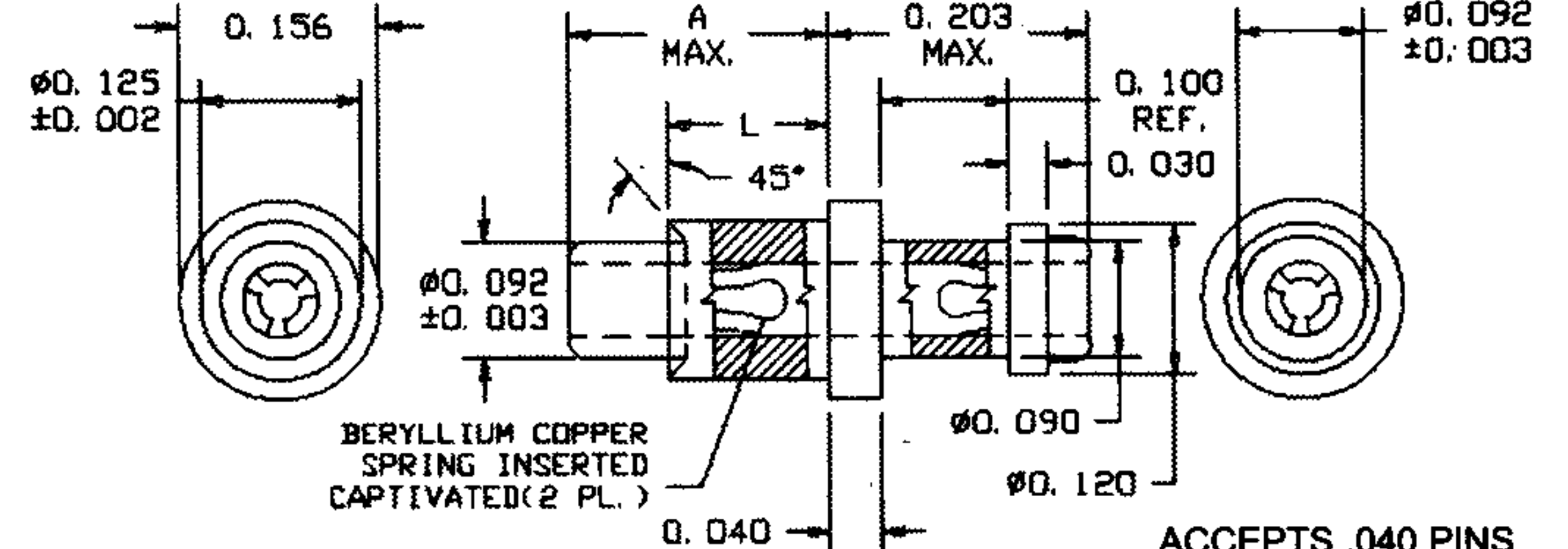

ACCEPTS .040 PINS (BOTH ENDS)(±.001)

PART NO.	L	A	BOARD THK.
09-9007-2	.094	.203	1/16
09-9007-3	.125	.203	3/32
09-9007-4	.156	.203	1/8
09-9007-6	.219	.250	3/16

INSTALLATION TOOLS

ANVIL	PUNCH
TA156-120-30	TP125-T93

RECOMMENDED MOUNTING HOLE .129±.002(#30 DRILL)

### MATERIAL

Body: Brass per ASTM B16

Spring Contact: Beryllium Copper per ASTM B194

### FINISH

Part Number/Finish Code	Body Finish	Spring Contact Finish
09-9XXX-X-03	Gold per ASTM B488	Gold per ASTM B488
04	Electro-Tin per ASTM B545	Electro-Tin per ASTM B545
06	Electro-Tin per ASTM B545	Gold per ASTM B488
063	Bright Tin-Lead per ASTM B545	Gold per ASTM B488
088	Bright Tin-Lead per ASTM B545	Bright Tin-Lead per ASTM B545

FOR ADDITIONAL SIZES AND MATERIALS, CONTACT FACTORY

800-847-4162 (Outside N.Y.S.)  
Ph: 212-777-6571 Fax: 212-991-0161  
sales@concord-electronics.com  
engineering@concord-electronics.com

