

**RECOMMENDED HOLE LAYOUT FOR
.062/(1.57) THICK P.C. BOARD**

CKT. SIZE	DIM. "A"	DIM. "B"
36	2.811 (71.40)	3.236 (82.20)
24	1.819 (46.20)	2.244 (57.00)
22	1.654 (42.00)	2.079 (52.80)
20	1.488 (37.80)	1.913 (48.60)
18	1.323 (33.60)	1.748 (44.40)
16	1.157 (29.40)	1.583 (40.20)
14	.992 (25.20)	1.417 (36.00)
12	.827 (21.00)	1.252 (31.80)
10	.661 (16.80)	1.087 (27.60)
8	.496 (12.60)	.921 (23.40)
6	.331 (8.40)	.756 (19.20)
4	.165 (4.20)	.590 (15.00)
2	—	.425 (10.80)

- NOTES:**
- HOUSING MATERIAL: A = NYLON 6/6. U.L. 94V-2. COLOR: NATURAL.
B = NYLON 6/6. U.L. 94V-0. COLOR: NATURAL.
C = PBT POLYESTER 94V-0 COLOR: BLACK
TERMINAL MATERIAL: BRASS ALLOY
 - TERMINAL PLATING
A = .000100/(.00254) MIN. MATTE TIN OVER
.000050/(.00127) MIN. NICKEL.
C = .000030/(0.00076) MIN. SELECT GOLD AND
.000100/(0.00254) MIN. SELECT MATTE TIN
OVER .000050/(0.00127) MIN. NICKEL OVERALL
D = .000060/(0.00152) MIN REFLOWED MATTE TIN OVER
.000050/(0.00127) MIN. NICKEL OVERALL.
 - PRODUCT SPECIFICATION: PS-5556-002
 - PACKAGING IN TRAYS PER PK-42404-002 EXCEPT 43693-0024 PACKAGED BULK
 - PART MATES WITH MINI-FIT JR. RECEPTACLES 5557, 42385, AND 42474
 - PART ALLOWS FOR UP TO .100(2.54) MISALIGNMENT WITH MATING RECEPTACLE IN ANY DIRECTION. SEE MATING CONNECTOR DRAWINGS FOR SPECIFIC ALLOWANCE.
 - PARTS ARE NOT DESIGNED FOR CURRENT SHARING.
 - CONNECTORS ASSEMBLIES ARE NOT TO BE MATED OR UNMATED WHILE CIRCUITS ARE LIVE.
 - SEE CHART ON SHEET 2 FOR STANDARD, MAKE-FIRST/BREAK-LAST AND PLATING LOCATIONS.
 - ITEM NUMBERS PRECEDED BY AN "X" IN THE CHART ARE NOT AVAILABLE.
 - REFERENCE DIMENSION "C" NOT TO EXCEED .283/(7.20) NOMINAL.
 - DISCOLORATION IN THE BANDOLIER CARRIER AREA OF THE PIN IS INHERENT TO THE PLATING PROCESS AND IS DUE TO THE MASKING EFFECT OF THE CARRIER. THIS DISCOLORATION IS IN A NON-FUNCTIONAL AREA OF THE PIN AND WILL NOT AFFECT THE PERFORMANCE OF THE HEADER ASSEMBLY.
 - PART CONFORMS TO CLASS "B" REQUIREMENTS OF COSMETIC SPECIFICATION PS-45499-002, EXCEPT CLASS "C" ON BOTH SIDE RIBS.
 - CUT OFF PEGS NOT TO PROTRUDE MORE THAN .030/(0.76)

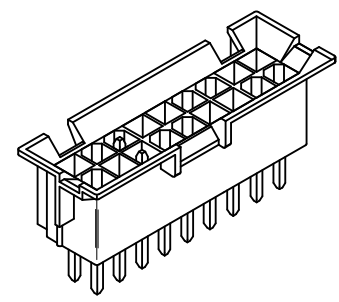

43693-****

CHANGE PLATING EC NO: UCP2012-1560 DRWINANGUYEN 2012/01/23 CHKD:JBELL 2012/01/23 APPR:FSMITH 2012/02/02	QUALITY SYMBOLS ∇=0 ∇=0 ∇=0	GENERAL TOLERANCES (UNLESS SPECIFIED)		DIMENSION STYLE IN/MM		SCALE 2:1	DESIGN UNITS METRIC	THIRD ANGLE PROJECTION	
		mm	INCH	DRAWN BY GEP	DATE 3/11/96	VERT. HEADER ASSY WITH MAKE-FIRST/BREAK-LAST MINI-FIT B.M.I. SERIES MOLEX INCORPORATED			
		4 PLACES ±---	±---	CHECKED BY RFJ	DATE 3/11/96				
		3 PLACES ±---	±.015	APPROVED BY RFJ	DATE 3/11/96	MATERIAL NO. SEE CHART		DOCUMENT NO. SDA-43693-****	SHEET NO. 1 OF 2
DRAFT WHERE APPLICABLE MUST REMAIN WITHIN DIMENSIONS		ANGULAR ±1/2°		SIZE C		THIS DRAWING CONTAINS INFORMATION THAT IS PROPRIETARY TO MOLEX INCORPORATED AND SHOULD NOT BE USED WITHOUT WRITTEN PERMISSION			

