

HS35 Absolute Encoder

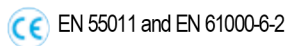

Built on the same rugged design as the incremental model, the HS35 Absolute Encoder is available with various output options including Gray Code and Natural Binary. Designed with a cast aluminum housing, a sealed connector and shaft seals, it carries an IP65 environmental rating. With the optional insulating inserts, it can be mounted on smaller diameter shafts. It is designed for either a through shaft mounting or blind shaft mounting with a closed cover to maintain its environmental rating.

The HS35 Absolute Encoder is available with the following certification:



Electrical Specifications

Options: Parallel: NB or GC 12-14 Bits (see Table 1)
 Serial (S3): 12-16 Bits (see Table 3)
 Analog: (A1-A5) 12-16 Bits (see Table 2)

Counts Per Shaft Turn: 4096–65536 depending on options
Count Transition Accuracy: $\pm 1/2$ bit maximum (Consult factory over 13 Bits)
Supply Voltage: 5–28 VDC ; 13-28 VDC for Analog
Current Requirements: 120 mA typical
Output Formats: **Parallel:** Gray Code, Natural Binary, Serial and Analog
Voltage/Output: (see note 2)
 28V/V: Line Driver, 5–28 VDC in, $V_{out} = V_{in}$
 28V/5: Line Driver, 5–28 VDC in, $V_{out} = 5$ VDC
 28V/OC: Open Collector, 5–28 VDC in, OC_{out}
 SSI: 5–28 VDC in/ $5V_{out}$ (consult factory for more information)
 Analog: A1-A5

Protection Level: Reverse, overvoltage and output short circuit protection
Frequency Response: 500kHz or 6000 RPM (Parallel)

Output Termination Pinouts: see tables
 For S3 options, reference Spec Addendum 02087-005
 For A1-A5 options, reference Spec Addendum 02088-002

Mechanical & Environmental Specs

Shaft Bore: many diameters from .375 to 1.000 inch are available, including metric. (Consult factory for details)
Allowable Misalignment: 0.005" T.I.R. on mating shaft 0.75" from shaft end
Bore Runout: 0.001 T.I.R. maximum
Starting Torque at 25°C: Through shaft version (SS) = 7 in-oz (max);
 Blind shaft version (BS) = 4 in-oz max
Bearings: 52100 SAE High carbon steel
Shaft Material: 416 Stainless Steel
Bearing Housing: Die cast aluminum with protective finish
Cover: Die cast aluminum with protective finish
Bearing Life: 7.5 X 10⁶ revs (50,000 hours @ 2500 RPM)
Maximum RPM: 6,000 mechanical (see frequency response, above)
Moment of Inertia: 0.019 oz-in-sec²
Weight: 18oz typical
Temperature: Operating, 0° to 70°C; Extended temperature ratings are available in the following ranges: -40 to 70°C, -40 to 85°C. Extended temperature ranges can affect other performance factors.

NOTES & TABLES: All notes and tables referred to in the text can be found on pages 2 & 3.

HS35 Absolute Encoder Ordering Options

FOR ASSISTANCE CALL 800-350-2727

Use this diagram, working from left to right to construct your model number (example: HS35F-100-R1-SS-12GC-28V/V-CW-SM14/19). All notes and tables referred to can be found on the back of this page.

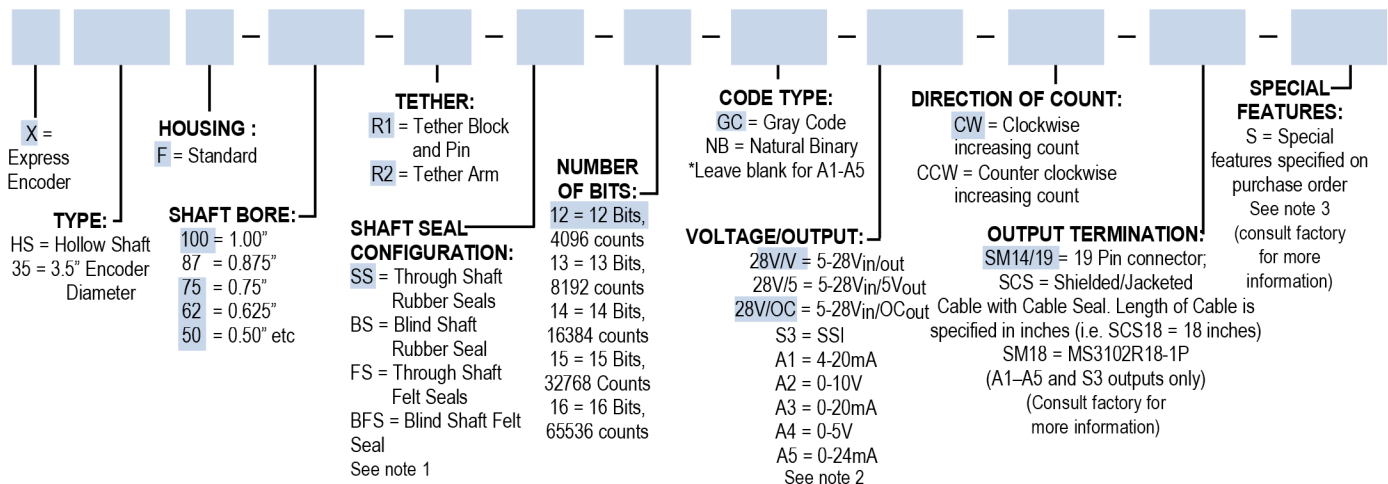

EXPRESS ENCODERS: ITEMS HIGHLIGHTED WITH ARE STANDARD EXPRESS ENCODERS AND SHIP IN ONE TO THREE DAYS. (consult factory for more information)

BEI and Express Encoder are registered trademarks of BEI Sensors and Systems Company.



Tel: 805-968-0782 / 800-350-2727 | Fax: 805-968-3154 / 800-960-2726
 7230 Hollister Ave., Goleta, CA 93117-2807 | www.beisensors.com

Specification No. 02070-001 Rev.5-14

Table 1: Parallel Output Code and Terminations

PARALLEL Gray or Natural code			TERMINATION	
14 BIT	13 BIT	12 BIT STD.	M14/19 CONN	CABLE COLOR
B13 (MSB)	B12 (MSB)	B11 (MSB)	A	W/BLK
B12	B11	B10	B	W/BRN
B11	B10	B9	C	W/RED
B10	B9	B8	D	W/ORN
B9	B8	B7	E	W/YEL
B8	B7	B6	F	W/GRN
B7	B6	B5	G	W/BLU
B6	B5	B4	H	W/VIO
B5	B4	B3	J	W/GRY
B4	B3	B2	K	WHT
B3	B2	B1	L	GRY/BLK
B2	B1	B0 (LSB)	M	GRY/BRN std
B1	B0 (LSB) OR NC		N	GRY/RED*
OV std. (BO_LSB 14 BIT or Enable, Dir C, latch)			P	GRY/ORN*
Dir Control std. (optional: latch or Enable)			R	ORN*
Case GND			S	GRN
OV RETURN			T	BLK
LATCH std. (optional: DC or Enable)			U	YEL*
+V SUPPLY			V	RED
SHIELD DRAIN			-	BARE
*Optional				

Table 2: Analog Termination and Options

Analog	M18	M14/19	CABLE COLOR
A1,2,3,4 & A5	M18	M14/19	CABLE COLOR
A+ OUT	A	A	YEL
A Return	H	B	W/YEL
Dir Control	C	U	ORN
Reset*	B	C	BLU
OV Return	F	T	BLK
+V Supply	D	V	RED
CASE GND	G	S	GRN
*Optional			

Table 3: SSI Termination

SSI	Termination		
	M18	M14/19	CABLE
DATA+	A	A	YEL
DATA-	H	B	W/YEL
CLK+	B	C	BLU
CLK-	I	D	W/BLU
Dir Control	C	R	ORN
ENABLE*	J	P	W/ORN
OV RETURN	F	T	BLK
+V SUPPLY	D	V	RED
CASE GND	G	S	GRN
SHIELD DRAIN	-	-	BARE
*Optional			

Ordering SSI : HOW TO SPECIFY SSI OUTPUT IN THE ENCODER MODEL NUMBER:
 Example: HS35-100-R2-SS-12-NB-S3-CW-SM18

Direction of Count: Standard is CW increasing when viewed from the shaft end. Pin R is normally HI (or N/C) and is pulled up internally to +V. To reverse the count direction, Pin R must be pulled LO (COMMON).

Latch control: Encoder outputs are active and provide continuous parallel position information when Pin U is HI (or N/C). Pin U is pulled up internally to +V. When Pin U is LO (COMMON) the encoder outputs are latched at the logic state that is present when the latch is applied and will stay latched until Pin U is no longer LO (COMMON).

M18 Connector is a MS3102R18-1P, 10-pin connector on the encoder body and mates to an MS3106F18-1S connector or can be used with a standard cable/connector assembly, BEI P/N 924-31186-18XX (Where XX = 10, 20 30 or 50 for a 10, 20, 30, or 50 foot length). This is the preferred connector for SSI output.

M14/19 Connector is a MS3112E14-19P, 19-pin connector on the encoder body and mates to an MS3116J14-19S or equivalent.

Figures

Figure 1
Gray Code

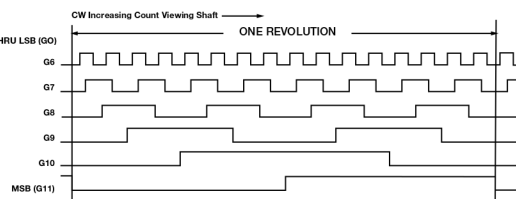
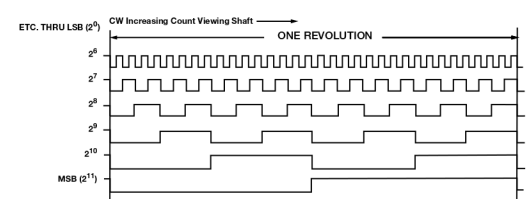

Figure 2
Natural Binary



Dimensions

MS Connector Termination

SM18 Conn.

Termination Options

SM14/19 Conn.

SCS CABLE

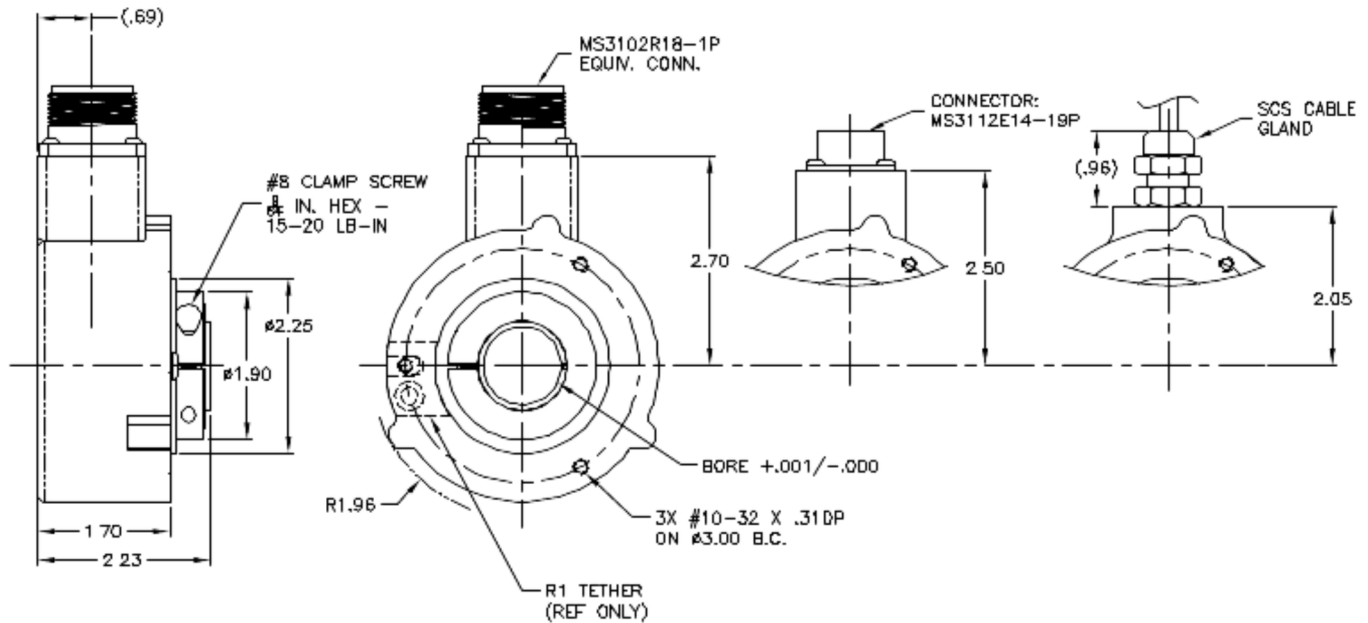

R1 Tether Block and Pin

R2 Tether Arm

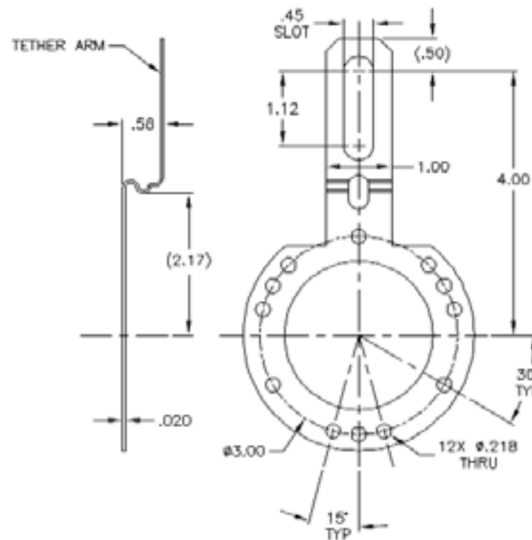
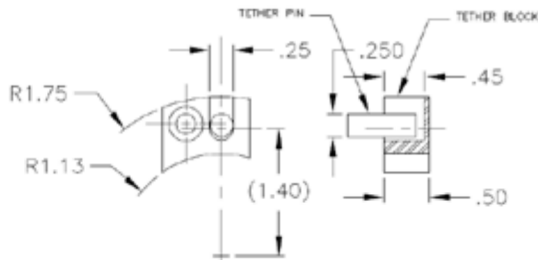

Notes

1. The rubber shaft seal is recommended in virtually all installations. The most common exceptions are applications requiring a very low starting torque or those requiring operation at both high temperature and high speed. For these exceptions, a felt shaft seal is recommended. Felt seals require very low starting torque and can virtually eliminate frictional heat. Encoders ordered with felt shaft seals will have an enclosure rating of IP50 and will have less than 1/10th the Starting Torque specified under Mechanical Configurations.

2. **Output IC's:** Output IC's are available as either Line Driver (LD) or NPN Open Collector (OC) types. Open Collectors require pull-up resistors, resulting in higher output source impedance (sink impedance is similar to that of line drivers). In general, use of a Line Driver style output is recommended. Line Drivers source or sink current and their lower impedance mean better noise immunity and faster switching times. **Warning:** Do not connect any line driver outputs directly to circuit common/OV, which may damage the driver. Unused outputs should be isolated and left floating. Our applications specialists would be pleased to discuss your system requirements and the compatibility of your receiving electronics with Line Driver type outputs.

28V/V: Multi-voltage Line Driver (7272*): 100 mA source/sink. Input voltage 5 to 28 VDC +/- 5% standard (Note: $V_{out} = V_{in}$). This driver is TTL compatible when used with 5 volt supply. Supply lines are protected against overvoltage to 60 volts and reverse voltage. Outputs are short circuit protected for one minute. Supply current is 120 mA typical (plus load

current). This is the recommended replacement for 3904R and 7406R open collector outputs with internal pullup resistors. It is also a direct replacement for any 4469, 68C30, 6830 or 26LS31 line driver

13-28VDC: For Analog

28V/5: Multi-voltage Line Driver (7272*): 100 mA source/sink. Input voltage 5 to 28 VDC +/- 5% standard, internally regulated with 5V (TTL compatible) logic out. Supply lines are protected against overvoltage to 60 volts and reverse voltage. Outputs are short circuit protected for one minute. Supply current is 90 mA typical (plus load current). Note: Limit encoder load to 2.5W max at ambient. Example at 12 VDC: $2.5W / (12VDC \text{ minus } +5VDC) = 357 \text{ mA}$ total allowed current. Consult factory for your specific requirements.

28V/OC: NPN Open Collector (3904*, 7273*). Current sink of 80 mA max. Current sourced by external pull-up resistor. Output can be pulled up to voltage other than supply voltage (30 V max). Input voltage 5 to 28 VDC +/- 5% standard. Supply current is 120 mA typical. This replaces prior IC's with designations of 3904, 7406, 3302, 681 and 689.

3. Special -S at the end of the model number is used to define a variety of non-standard features such as special shaft lengths, voltage options, or special testing. Please consult the factory to discuss your special requirements.

* Products manufactured prior to April 2007 used the line driver IC number instead of voltage output in model number.